



Next Generation Networks

Future arrangements for access and interconnection

Consultation

Publication date: **13 January 2005**

Closing Date for Responses: **25 November 2004**

Contents

Section		Page
1	Summary	2
2	Introduction	10
3	Application of Ofcom's proposed regulatory principles to NGNs	17
4	Transition to the new world	36
5	Service specific issues	40
6	Summary and way forward	52
7	Responding to this consultation	55
 Annex		 Page
2	Ofcom's consultation principles	57
3	Consultation response cover sheet #	58
4	Consultation questions	60
5	Glossary	66

Section 1

Summary

Introduction

- 1.1 This document explores the implications of Next Generation Networks (NGNs) for access and interconnection arrangements in the UK. Ofcom believes there is an opportunity for the development of competing next generation core networks. However, a key pre-requisite for the development of these networks is the availability of access and interconnection to BT's network. Therefore this document has particular focus on the regulatory and competitive implications of BT's NGN plans, known as '21st Century Network' (21CN).
- 1.2 In considering those implications, we take the principles proposed in Phase 2 of Ofcom's Strategic Review of Telecommunications ('Telecoms Review'), and consider their practical application to NGNs in general and 21CN in particular. In doing so Ofcom hopes to facilitate the timely development of access and interconnect arrangements consistent with those principles.

Background: NGNs and 21CN

- 1.3 A number of operators are currently considering plans to deploy 'Next Generation Networks' (NGNs). NGNs essentially deliver convergence between the traditional world of public switched telephone networks, and the new world of data networks. From an operators perspective they provide a means of migrating from the old world to the new world, delivering substantial cost savings due to the economies of scope inherent in a single converged network. From a consumers perspective they can offer innovative new services, greater control and personalisation, ease of migration between services as well as offering continuity for existing PSTN services.
- 1.4 BT set out specific proposals for its NGN, 21CN, earlier this year and this is likely to be one of the most significant deployments of NGN technology anywhere in the world. However, other operators are known to be developing similar deployment plans, including most of the operators that compete with BT in the UK market.
- 1.5 BT's plans for 21CN are for a new single multi-service network to replace all of its existing networks. BT's stated aims for the programme are to reduce costs (by £1 billion per annum by 2008/09), improve speed to market for new services, and improve customer experience¹
- 1.6 BT also set out several key milestones for its programme:
 - Trials of the new technology were to be initiated during 2004, with next generation voice services being delivered to 1,000 customers by Jan 2005.
 - Broadband services will be available to 99.6% of UK homes and businesses by summer 2005, with growth in broadband services being met by a new 'Multi-Service Access Node' platform.
 - The mass migration of PSTN customers is expected to start in 2006, and reach more than 50% by 2008.
 - Broadband dial tone is expected to be available to most customers in 2009

¹ BT news release June 9th 2004

Ofcom's involvement

- 1.7 21CN represents the most significant change in BT's network since competition was introduced two decades ago. Major technology changes, which occur naturally in competitive as well as regulated markets, are always likely to disrupt existing models of competition. In this case it also creates the first ever opportunity to ensure that the network of an incumbent operator accommodates competition from the outset. Furthermore, it coincides with the establishment by the Telecoms Review of a new regulatory settlement
- 1.8 Ofcom's role is to ensure that there is clarity as to the regulatory policy requirements necessary to support effective competition. This does not mean that it is either desirable or appropriate for Ofcom to become involved in the detailed design of BT's network. Ofcom must however ensure that BT is able to provide access to its network in a manner that supports the further development of competitive markets. By providing clarity as to those regulatory policies that flow from this access obligation, Ofcom can help BT and others be clear about the constraints within which they should design their networks. That is the purpose of this consultation process.
- 1.9 Ofcom considers that its approach to NGNs should be guided by the key regulatory principles proposed in the Telecoms Review. They are that Ofcom should:
1. promote competition at the deepest levels of infrastructure where it will be effective and sustainable;
 2. focus regulation to deliver equality of access beyond those levels;
 3. as soon as competitive conditions allow, withdraw from regulation at other levels;
 4. promote a favourable climate for efficient and timely investment and stimulate innovation, in particular by ensuring a consistent and transparent regulatory approach;
 5. accommodate varying regulatory solutions for different products and where appropriate, different geographies;
 6. create scope for market entry that could, over time, remove economic bottlenecks; and
 7. in the wider communications value chain, unless there are enduring bottlenecks, adopt light-touch economic regulation based on competition law and the promotion of interoperability.
- 1.10 This consultation focuses on questions and issues raised by the practical application of the first five principles to NGNs and explores some of the issues raised in the Telecoms Review in more detail. It does not set out preferred solutions, since solutions are more likely to be effective if they are determined by industry, through a process of commercial negotiation, than if they are determined by regulatory intervention. Ofcom must however be prepared to become more directly involved where the process of commercial negotiation fails.

Application of Ofcom's proposed regulatory principles to 21CN

The regulatory principles

1.11 We start by considering the general application of each of the regulatory principles to NGNs, with particular reference to BT's 21CN. The first four principles are all relevant, and are considered in turn, since they tend to raise distinct issues. The fifth principle is also relevant, but tends to cut across the first four. The last two principles are less relevant to NGNs.

Principle 1: Competition at greatest depth

Two aspects to 'depth' are considered:

1.12 Geographic depth within the topology of 21CN, ie how close to the customer is access provided. There are three geographic levels within 21CN at which it might be possible to provide access: the local loop (MDF/MSAN sites), the metro node and the core node. It is likely that a combination of access remedies will be required, focussing on access at MDF/MSAN sites in those geographies where this is likely to result in sustainable competition, and providing metro node access elsewhere.

1.13 Service level depth. There is likely to be a choice between end-to-end services (e.g. wholesale calls), service-specific interconnection services (e.g. voice call origination), a generic interconnection service (e.g. bitstream interconnection) or physical unbundling (e.g. LLU). Consistent with its regulatory principles, Ofcom believes regulation should be focussed as deep in this service stack as possible, recognising that this might vary with different geographies. If, for example, some form of access is made available at the MSAN, then there would be a preference for this to be at the physical or bitstream level rather than service specific.

Principle 2 : Equality of access.

1.14 The design of key regulated access and interconnection products must support equality of access. In particular, new regulated 21CN access and interconnect products will need to support 'equivalence of inputs', so that BT uses the same products, at the same price, managed using the same systems and processes as alternative providers. Reduced time to market is expected to be one of the key benefits of 21CN, so an effective process for the introduction of new regulated products will also be important. Even where existing regulated products currently support equivalence of access, they may have to evolve in light of new capabilities introduced by 21CN. For example, the requirement to support equivalence of access to the local access network might require changes to the existing LLU service, and may require consideration of some form of bitstream access at the MSAN.

Principle 3: Regulatory withdrawal.

21CN might allow for regulatory withdrawal because:

1.15 21CN may be the vehicle for the delivery of improved equivalence in relation to BT's wholesale services. This should allow other providers to compete in downstream markets and create the conditions where BT's downstream services, particularly at the retail level, could be deregulated.

1.16 At the wholesale or network level a key theme of 21CN is convergence. If convergence is effective, this should allow a reduction in service specific wholesale regulation, and a

greater focus on generic access and interconnection remedies (LLU, bitstream interconnection).

Principle 4: Favourable climate for investment.

1.17 An important general principle is that regulation of NGNs should not simply be seen as a 'zero-sum' game, where Ofcom's primary concern is to decide how the benefits of BT's investment in 21CN should be divided between BT and the rest of industry. Instead, the aim should be to promote a favourable investment climate for industry as a whole, in order to deliver the greatest possible benefit to consumers of an industry wide migration to NGN.

1.18 There are a number of ways in which Ofcom can influence the investment climate:

- Providing regulatory clarity and predictability
- Ensuring alternative providers have confidence in BT's regulated products
- Setting appropriate regulated returns for BT's regulated products, that take account of the commercial and technical risks associated with its investment in 21CN
- Ensuring the migration to 21CN minimises the impact on existing investments (and thereby also minimises the perceived risk associated with new investments) whilst enabling BT to close its existing networks as soon as reasonable

Application of principles to key forms of access and interconnection

1.19 The practical application of these principles is considered in four key areas:

- Access and interconnection at the level of the local access network (MDF sites / MSAN nodes)
- Access and interconnection at the level of the core network (Metro nodes)
- Access to the intelligence and applications layers of 21CN
- Systems and processes

The focus at this stage is on generic access and interconnection remedies, such as physical unbundling and bit-stream interconnection, which can be used to deliver a broad range of downstream services.

Access at the local access network level (MDF/ MSAN site)

1.20 At the MDF/ MSAN site there are two main alternatives for the provision of access to the local access network, ie local loop unbundling (LLU), and some form of interconnection with the MSAN. Applying the first regulatory principle, Ofcom would favour the deeper option, ie LLU, where this can lead to effective and sustainable competition. However, two factors suggest that an alternative to LLU, ie some form of interconnect with the MSAN, should be considered, at least in some areas, as a more effective means of promoting competition at this level.

- BT's deployment of 'broadband dial-tone' to its narrowband customers could create a major challenge for LLU-based operators. BT will be able to migrate customers to broadband almost immediately whilst the manual LLU process is likely to take several days at best.
- LLU is unlikely to be viable in all geographies, particular in those areas (eg rural areas) where there is a lower number of households connected to each MDF site.

But if metro interconnect is the only alternative option where LLU is not viable, any potential for competition in backhaul **would be eliminated**.

- 1.21 A number of options are explored for MSAN interconnection, including 'soft LLU' where operators might take control of a line card in BT's MSAN and pick up the associated transport stream using some form of bitstream interconnection.

Access at the core network level (Metro node).

- 1.22 The current level of interconnection with BT's existing core network suggests that conveyance between metro nodes is potentially competitive. However, in moving to 21CN there may be differences in the location and topology of metro nodes compared to existing networks which might, albeit temporarily, lessen competition at this level.

Intelligence and application layers.

- 1.23 It is possible that 21CN will create new access bottlenecks at the intelligence and application layers. For example, an alternative provider may be able to deliver a voice service based on the use of bitstream access at the MSAN, but they may need access to additional functionality at the application layer (e.g. customer location data, session control functionality) in order to be able to compete effectively. Some of these functions may be needed on a reciprocal basis, others may relate solely to BT, whilst others could be developed on a commercial basis.

Systems and processes.

- 1.24 The operational processes and systems associated with key products must support equality of access, so that alternative providers are able to order and manage key products using the same processes and systems as BT's retail activities. A key enabler of this is likely to be BT's Next Generation OSS, a distributed OSS architecture based on off-the-shelf commercial systems linked by standard industry interfaces. This is expected to replace the vertically integrated OSS systems currently in use.

Transition to the new world

- 1.25 The transition from the current world to the world of NGNs raises particularly complex issues. These generally divide into issues associated with product migration, and issues associated with geographic rearrangement.
- 1.26 21CN will require a number of product migrations – from dial-up internet access to always-on IP, from PSTN voice to voice over IP, from traditional SDH leased lines to Ethernet, from ATM to IP/MPLS, from voice VPNs to IP VPNs, and so on. These migrations are the inevitable consequence of the new network technology, and will deliver benefits to industry as a whole, as well as consumers. They will however have to be carefully project managed, and will almost certainly require the establishment of new cross-industry working groups and processes. Where retail services are based on current regulated wholesale products, it will be particularly important to ensure that those retail services are not disrupted because of changes in the underlying network inputs.
- 1.27 21CN will also lead to substantial geographic rearrangement of networks. This is likely to be more contentious, since the benefits are asymmetric. A key goal of regulatory policy over the last 20 years has been to encourage competition in conveyance services, by providing incentives for alternative operators to build out to as many points of interconnection with BT as possible. This has been successful, particularly in relation to voice conveyance. However, many of the points of interconnection to which

other operators have deployed may no longer be available within 21CN, since BT proposes to shift many of the points of interconnection within its trunk network, and withdraw interconnection at local exchange level. Unlike the product migration, whilst BT may benefit from this change, alternative providers could face significant costs.

- 1.28 It would clearly not be appropriate for Ofcom to determine the locations of BT's network nodes. However, it is important that BT takes account of the costs imposed on alternative providers when re-arranging its network. One way of ensuring this is if BT recompenses alternative providers for these costs. Ofcom would prefer that the level and form of compensation is resolved through commercial negotiation, but is prepared to become more directly involved where necessary.

Service specific issues

- 1.29 21CN raises a number of issues specific to particular services. In relation to voice services the issues include:

- Current voice competition is based largely on the ability of alternative providers to purchase call origination from BT, using Indirect Access (IA), Carrier Pre-Selection (CPS), and Number Translation Services (NTS). Over the last few years IA/CPS/NTS operators have built out extensively, first to BT's trunk exchanges and more recently to BT's local exchanges. BT will need to give particular consideration to these operators during the proposed re-arrangement of points of interconnection.
- Voice competition also depends on the ability of alternative providers to purchase narrowband access from BT, in the form of Wholesale Line Rental. However, 21CN will result in technical convergence of narrowband and broadband access. These will not only use the same copper loop, they will also use the same (or at least similar) line-cards in the same MSAN. It will be necessary to consider whether separate narrowband and broadband access products continue to make sense in the world of 21CN. An alternative would be a converged wholesale access product covering narrowband and broadband.
- We expect competition based on Voice over IP to become increasingly important. This is likely to require some form of Quality of Service (QoS) enabled bitstream interconnection, and it may also require access to some application-layer functionality. A substantial amount of work is required to specify this form of access, which will be an important basis for facilitating competition in converged voice and data services. This may allow some withdrawal of voice-specific regulation, although we would need to ensure that competition was also effective for customers not buying broadband services.

- 1.30 In relation to residential data services:

- We expect 21CN to result in further erosion of dial-up internet access. It is unlikely to be efficient to provide IP services using voice-band modems, when the voice-band signal is in turn being carried over an IP network. Flat rate dial-up services are likely to disappear first, since they are already similar in price to entry-level broadband services, and so it may be appropriate to agree a process for the future withdrawal of FRIACO in line with customer demand. Metered dial-up services are likely to be required for longer, but may eventually be displaced by entry-level internet access services based on native-mode IP.
- Alternative providers wishing to interconnect with BT in order to provide data services can currently do so using either ATM (DataStream) or IP (IPStream). The margin between these two is regulated by Ofcom. However, 21CN is likely to result in convergence of these different layers of interconnection, and therefore erosion of

the regulated margin between them. It might be appropriate to replace the two existing forms of broadband interconnection with a single converged IP interconnection service, including the option of a basic 'best-efforts' service, as well as the option of MPLS-based QoS management.

- A key aim of 21CN is that it will provide 'broadband dial tone' to all BT's narrowband customers. Consumers will be able to plug a broadband device into their phone line, and immediately be able to subscribe to BT's broadband service just as they can turn on 'select services' today. However, whilst seamless migration from narrowband to broadband is clearly beneficial for consumers, it creates a major challenge for LLU-based operators. LLU will have to evolve significantly if it is to support 'equality of access' when compared to broadband dial tone. A suitable approach to LLU-based competition founded on the concept of equivalence needs to be identified in a NGN world.

1.31 In relation to business services:

- Competition in the business market is under-pinned by the availability of wholesale access from BT, currently in the form of SDH-based PPCs. However, there is already a trend in the business market towards new transmission technologies, notably Ethernet, and this is likely to accelerate as 21CN-driven convergence allows Ethernet to be used for voice as well as data services. A wholesale Ethernet access service is likely to be required, but will be different in design to the current PPC design, due to major differences between SDH and Ethernet technology.
- It is possible that traditional leased line services will be provided on 21CN using circuit emulation technology over an ATM or IP/MPLS network. However, this may be inefficient. It might be more effective for BT to provide direct access to virtual ATM or IP/MPLS transmission capacity, via a service similar in character to the current DataStream service.
- A more focussed option might be to address the underlying access bottleneck for businesses services directly, and do so at the deepest possible service level, deregulating elsewhere. One means of doing so might be for BT to provide selective access to dark fibre in those geographies where it has significant market power (SMP). This might reduce the need for the more widespread regulation of downstream products such as PPCs.

Industry Engagement

1.32 Ofcom is keen to provide clarity over the principles of the regulatory regime as soon as possible in order to support industry negotiations on 21CN access and interconnection. However, for such a negotiation process to be effective, it will be necessary for BT to engage in an open and transparent manner with alternative operators. It will also be necessary for alternative operators to commit significant resource, commercial and technical, to the development of possible solutions.

1.33 Ofcom recognises that many of the issues raised by 21CN are technical in nature; for example new interconnect products may depend on the development of appropriate technical standards. In the past these would have been expected to have been addressed by the UK Network Interoperability Consultative Committee (NICC). However, the level of challenge created by 21CN is likely to require some restructuring of NICC, in order to provide adequate focus on 21CN issues, and is likely to require a significantly increased level of resource commitment from industry. One means of improving the level of engagement between operators and NICC might be for Chief Technology Officers of the major operators to attend NICC board meetings. Ofcom

encourages the exploration of this and other options for ensuring that the technical issues raised by 21CN are addressed in a timely manner.

Next steps

- 1.34 Ofcom is committed to helping the industry meet the ambitious timetable set out for the implementation of next generation networks. This consultation closes on 13th January 2005. Ofcom expects to publish a statement early in 2005 summarising the responses, and considering how to take the various issues forward.

Section 2

Introduction

2.1 This document explores the implications of BT's Next Generation Network (NGN) plans, known as '21st Century Network' (21CN), for access and interconnection arrangements in the UK. It focuses on the potential competition and regulation issues, rather than the more commercial focus of BT's consultation process with industry (known as Consult 21). In particular, it takes the principles proposed in Phase 2 of Ofcom's Strategic Review of Telecommunications ('Telecoms Review'), and considers their practical application to 21CN. In doing so Ofcom hopes to facilitate the timely development of next generation access and interconnect arrangements consistent with those principles.

Background

- 2.2 A number of operators are currently considering plans to deploy 'Next Generation Networks' (NGNs). NGNs can be defined in terms of both their technical characteristics and their service characteristics. The key technical characteristics of NGNs are that they provide:
- A single IP-based core network handling the full range of telecoms services
 - A single access platform supporting the full range of access technologies and services (typically referred to as a Multi Service Access Node or MSAN)
 - Distributed rather than centralised switching, routing and network intelligence enabling remote access, control and maintenance
- 2.3 NGNs essentially deliver convergence between the traditional world of public switched telephone networks, and the new world of data networks. From an operators perspective they provide a means of migrating from the old world to the new world, delivering substantial cost savings due to the economies of scope inherent in a single converged network
- 2.4 NGNs also have important service characteristics, as seen from the perspective of a consumer:
- Continuity - Consumers will be able to continue to use those PSTN services they are used to, with essentially no change, if that is what they desire.
 - Ease of migration - Consumers will be able to migrate seamlessly to new services offered by the same network operator
 - Innovative new services – New services will have richer functionality (eg personalised, location-aware), and reduced time-to-market, since they exploit the distributed intelligence inherent to an NGN.
 - Empowerment – Consumers will have an increased capability to configure and manage services to meet their personal requirements.
- 2.5 BT has set out specific proposals for its NGN, 21CN, and this is likely to be one of the most significant deployments of NGN technology anywhere in the world. However, most other operators are known to be developing similar deployment plans, including those operators that compete with BT in the UK market. Some operators have already deployed this technology in their existing networks. Telecoms operators are moving to NGNs for a number of reasons, including:

- Existing PSTN equipment may be reaching the end of its life, for example with ongoing support being harder and more costly to obtain.
 - Operational costs can be reduced by running a single network rather than multiple legacy networks
 - Innovative services can be developed to improve customer experience
 - New services can be brought to market faster and at lower cost than is possible using traditional technology.
- 2.6 It is important to note that the basic concept of an NGN is the evolution towards a converged IP-based core network. This is delivered by means of changes in the equipment used for transmission and switching, rather than by changes in the underlying physical infrastructure. The issues raised by the deployment of NGNs are therefore somewhat distinct from those raised by changes in the underlying physical infrastructure, such as the deployment of fibre to the home. The issues associated with next generation access networks are outside the scope of this document.

BT's 21st Century Network (21CN)

- 2.7 BT set out its plans for 21CN earlier this year. It will replace all of BT's existing networks with a single multi-service network. BT's stated aims for the programme were to reduce cash costs (by £1 billion per annum by 2008/09), improve speed to market for new services, and improve the customer experience²
- 2.8 BT also set out several key milestones for its programme:
- Trials of the new technology are to be initiated during 2004, with next generation voice services being delivered to 1,000 customers by Jan 2005.
 - 99.6% of UK homes and businesses will be connected to a broadband enabled exchange by summer 2005.
 - Subsequent growth in broadband services will be met by a new 'Multi-Service Access Node' platform
 - The mass migration of PSTN customers is expected to start in 2006, and reach more than 50% by 2008.
 - Broadband dial tone is expected to be available to most customers in 2009
- 2.9 As set out in Figure 1, the new network has a much simpler and flatter structure than much of BT's existing networks, with just three main levels to the network. These are the ~6000 sites at which MDFs and MSANs are located, the ~120 metro nodes, and the ~10 core nodes. Notably for other providers, BT has indicated that all interconnect will take place via approximately 120 metro nodes.

² BT news release June 9th 2004

Figure 1. Comparison of existing BT voice and broadband networks with 21CN

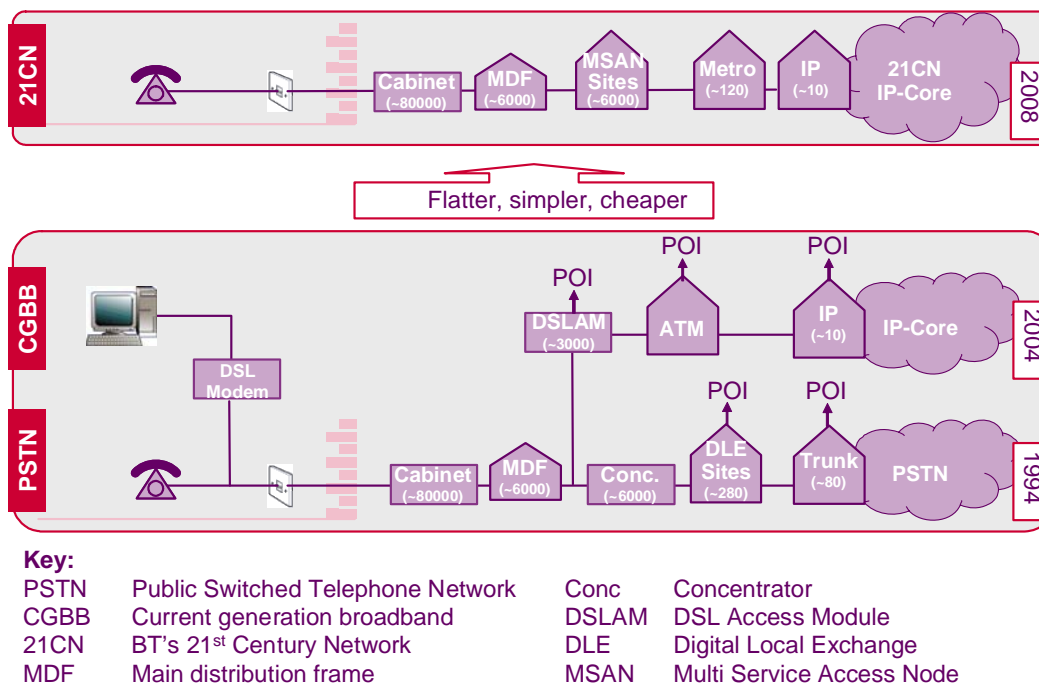

2.10 BT also set out plans for a 'deep fibre' trial, extending fibre further into the access network. However, although these trials are clearly of interest, they raise very different issues from the rest of BT's NGN proposals, and we therefore consider them to be out of scope of this document. We are considering the policy implications of next generation access in the Telecoms Review.

Basis for Ofcom involvement

2.11 21CN represents the most significant change in BT's network since competition was introduced two decades ago. Over that period, an extensive and complex set of access and interconnection regulation³ has evolved to cover a range of BT's services in markets where it has significant market power (SMP). The justification for such ex-ante regulation has been the need to address market failures and entry barriers that might otherwise prevent effective competition from becoming established. This process has culminated in a series of market reviews recently completed under the new EU regulatory framework.

2.12 As a result BT currently faces a number of access and interconnection related obligations, for example requirements to:

- offer Indirect Access(IA), Carrier Pre-Selection (CPS), and Wholesale Line Rental (WLR)
- offer Flat Rate Internet Access Call Origination (FRIACO) and Network Translation Service (NTS) calls

³ Interconnection is a specific type of access that entails the physical or logical linking of PECNs used by one or more providers in order to enable the customers of one provider to be able to communicate with customers of another provider, or to access services provided by another provider. In the rest of this document the term "access" is used to include "interconnection"

- offer Local Loop Unbundling (LLU) and the DataStream wholesale broadband access service
 - offer wholesale Partial Private Circuits (PPCs)
- 2.13 The detailed characteristics, charges and service levels of these interconnect products have emerged over several years as a result of lengthy industry negotiations and often detailed intervention by Oftel. Alternative communications providers have entered the market and built their business models on the basis of these regulated interconnect products. For example, some providers have extended their networks and connected to BT's local exchanges to support competitive CPS based offerings in the retail market. Others have built businesses based on the termination of NTS and FRIACO traffic for major ISPs. A variety of competing broadband services are now emerging based on LLU and DataStream. Therefore, the future of access and interconnection arrangements is crucial to most industry players.
- 2.14 As set out in this document, BT's planned move to 21CN raises many questions and issues for these existing regulated products. All of them will have to evolve if they are to be effective as a means of enabling competition in a world of NGNs. However, this is not an argument for remaining with the status quo. Major technology changes, which occur naturally in competitive as well as regulated markets, are always likely to disrupt existing models of competition. Rather, the move to 21CN should also be viewed as creating the first ever opportunity to ensure that access and interconnection to an incumbent's network supports competition from the outset, thereby creating an environment where regulation can be focused on key bottlenecks and rolled back elsewhere. Furthermore, the changes and opportunities created by 21CN coincide with the creation of Ofcom and its Telecoms Review, which is currently consulting on proposals for a new regulatory settlement in telecommunications.
- 2.15 Given the scale of this change and opportunity it is now vital for all players to consider what the next generation of access and interconnection arrangements will look like. BT and its wholesale customers have the leading role to play in defining these new arrangements. We believe Ofcom's role should be to ensure that there is clarity as to the regulatory principles and policies necessary to support effective competition in the new world. This does not mean that it is either desirable or appropriate for Ofcom to become involved in the detailed design of BT's network. We must however ensure that BT is able to provide access to its network in a manner that supports the development of a competitive market. By providing clarity as to the regulatory policies that flow from this access obligation, Ofcom can help BT and others be clear about the constraints within which they should design their networks. That is the purpose of this consultation process.

Scope of this consultation

- 2.16 Ofcom considers that its approach to NGNs should be guided by the key regulatory principles proposed in the Telecoms Review. They are that Ofcom should:
1. promote competition at the deepest levels of infrastructure where it will be effective and sustainable;
 2. focus regulation to deliver equality of access beyond those levels;
 3. as soon as competitive conditions allow, withdraw from regulation at other levels;

4. promote a favourable climate for efficient and timely investment and stimulate innovation, in particular by ensuring a consistent and transparent regulatory approach;
 5. accommodate varying regulatory solutions for different products and where appropriate, different geographies;
 6. create scope for market entry that could, over time, remove economic bottlenecks; and
 7. in the wider communications value chain, unless there are enduring bottlenecks, adopt light-touch economic regulation based on competition law and the promotion of interoperability.
- 2.17 NGNs raises fundamental questions relating to many of these principles, for example, do they change the nature of appropriate access remedies? How can equivalence be ensured for regulated access services? Can regulation be withdrawn elsewhere? How do we promote a favourable environment for investment in NGNs by BT and other operators? Do the answers to these questions vary geographically?
- 2.18 The scope of this consultation is necessarily very wide. Given this wide remit, the current focus is on identifying issues, and guiding principles for their resolution, rather than on presenting particular solutions. Solutions are more likely to be effective if they are determined by industry, through a process of commercial negotiation, than if they are determined by regulatory intervention.
- 2.19 Ofcom's expectation is that many, if not most, of the issues identified here can be resolved through commercial negotiation. Inclusion of an issue or question in this document does not signal that Ofcom is seeking to resolve it through regulatory intervention. In particular, the issues and questions included are by their nature exploratory, and should not be read as proposing specific regulatory intervention by Ofcom, nor as a change to the current regulatory framework.
- 2.20 However, it would equally be unwise to assume that all issues can be resolved without regulatory attention and we must be prepared to become more directly involved where the process of commercial negotiation fails. By identifying as many as possible of these issues at an early stage, we aim to ensure that any regulatory intervention that is required is carried out in a timely manner, thereby minimising uncertainty and regulatory risk. Where an issue is identified as potentially requiring regulatory involvement, Ofcom would expect proposals to address that issue to be explored as a result of this consultation.
- 2.21 Although many of the questions and issues raised here are also raised in the Telecoms Review, particular Section 8 and Annex H, the aim of this consultation is to explore those issues in more detail. Where there is an overlap between the more detailed questions in this consultation and the Telecoms Review, there is no need to answer the related questions in the Telecoms Review (see Annex C for specific questions).

Timing of consultation

- 2.22 Over the last few months Ofcom has been in informal discussion with BT and other operators about the potential implications of NGNs in general, and 21CN in particular. We are now at a point where BT has made much of the architecture of 21CN public but where new access and interconnection arrangements have yet to be specified in

detail. BT has launched a consultation process with industry ('Consult 21') and other providers are becoming engaged. Ofcom has also recently published phase 2 of its Telecoms Review, and set out proposals for a new regulatory settlement in telecommunications. We therefore believe we are at a crucial stage in the evolution of access and interconnect arrangements. In undertaking this consultation now, our aim is to facilitate and support the development of these new arrangements, rather than to slow or hinder them.

2.23 We recognise that the issues raised in this document are complex, and that this fact might normally justify a full 10 week consultation period. However, in this case, we think that there is an urgent need to move more quickly in order to:

- provide regulatory clarity to support the ongoing commercial discussions between BT and other providers;
- identify those issues which are likely to be resolved commercially, and where Ofcom should not therefore intervene; and
- identify and focus on any issues where there are genuine competitive and regulatory concerns, with the aim of resolving these as soon as possible.

2.24 A shorter consultation period is appropriate because although a wide range of issues is being presented, the aim of this consultation is not to determine solutions. Our primary aim is to identify issues, and do so in a timely manner, so that these can be properly considered as early as possible in the process of designing 21CN. The earlier in the design process that issues can be identified, the more likely it is that a cost-effective solution can be found.

2.25 We therefore propose a 5-week consultation period (excluding a 2-week period covering Christmas and the New Year). This consultation period will therefore close on January 13th 2005.

Structure of document

2.26 The rest of this document covers:

- **Where are we going**

Section 3 considers the goals for future access and interconnection arrangements by applying the proposed regulatory principles from the Telecoms Review to NGNs. In particular it considers

- access and interconnection at the level of the local access network and core network;
- new forms of access at the intelligence layer;
- practical issues associated with systems and processes;
- how regulation can be as focussed as possible in the new world; and
- how a favourable climate can be created for investment in NGNs, by BT and by other operators

- **How do we get there**

There is already a complex set of access and interconnect arrangements that has

evolved over many years. Section 4 considers the general issues for product and geographic migrations during the transition from the old to new world. Section 5 considers the many service-specific issues raised by existing products, from DLE interconnect to Datastream, and how these products may need to evolve. Section 6 considers what the next practical steps need to be.

Section 3

Application of Ofcom's proposed regulatory principles to NGNs

Introduction

- 3.1 This section considers the goals for future access and interconnection arrangements by applying the proposed regulatory principles from the Telecoms Review. These are that Ofcom should:
1. promote competition at the deepest levels of infrastructure where it will be effective and sustainable;
 2. focus regulation to deliver equality of access beyond those levels;
 3. as soon as competitive conditions allow, withdraw from regulation at other levels;
 4. promote a favourable climate for efficient and timely investment and stimulate innovation, in particular by ensuring a consistent and transparent regulatory approach;
 5. accommodate varying regulatory solutions for different products and where appropriate, different geographies;
 6. create scope for market entry that could, over time, remove economic bottlenecks; and
 7. in the wider communications value chain, unless there are enduring bottlenecks, adopt light-touch economic regulation based on competition law and the promotion of interoperability.
- 3.2 Firstly, the implications of these principles are considered in the context of 21CN. Principles 1 to 4 are specifically discussed as they are the most relevant to the future of access and interconnection arrangements, whilst principle 5 is recognised as being relevant throughout the discussion. Principle 6 is less relevant in the context of 21CN as it relates primarily to market entry (particularly from wireless services) and is not considered further here. Principle 7 is also not considered here because although next generation networks are related to the wider communications value chain (for example being linked to development of new applications and terminal equipment), the proposed approach to regulation of this wider value chain is not based on ex ante access obligations.
- 3.3 Secondly, the questions raised by the practical application of these principles are considered in four key areas:
- Access and interconnection at the level of the local access network (MDF sites / MSAN nodes)
 - Access and interconnection at the level of the core network (Metro nodes)
 - Access to the intelligence and applications layers of 21CN
 - Systems and processes

3.4 The general focus of this section is on generic access and interconnection remedies, such as physical unbundling and bit-stream interconnection, which can be used to deliver a broad range of downstream services. The questions raised for service-specific remedies, how they might evolve, and whether they will still be required, are discussed in Section 5.

Principle 1: Competition at deepest level

3.5 Several of the issues raised by 21CN touch on the first of Ofcom’s principles, that we should promote competition at the deepest levels of infrastructure where it will be effective and sustainable. There are two aspects to ‘depth’ considered here:

- geographic depth; and
- service level depth.

Geographic depth

3.6 Firstly, there is the familiar question of where within the geographic topology of 21CN, ie how close to the customer, is competition sustainable and therefore regulation should be focussed. As illustrated by Figure 2, there are conceptually three geographic levels within BTs 21CN at which access could be provided. These are the ~6000 sites at which MDFs and MSANs are located, the ~120 metro nodes, and the ~10 core nodes.

Figure 2. 21CN geographic levels

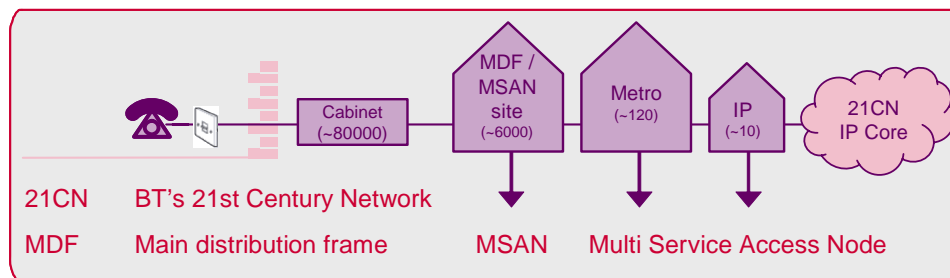

3.7 Table 1 below provides a summary of Ofcom’s current thinking on the potential for competition at each of the geographic levels. Note that this is not necessarily the same as the current level of competition at these levels.

Table 1: Potential for competition at different geographic levels

Geographic level	Number of locations	Potential for effective and sustainable competition based on access at this level
Local (MDF / MSAN site)	~6000	Urban and some suburban areas. Unlikely to lead to effective and sustainable competition in all rural areas.
Metro	~120	Yes, potential for competition
Core node	~10	Yes, potential for competition

3.8 Ofcom’s first principle implies that regulation should be focussed on the access network, which is generally seen as an enduring economic bottleneck⁴, rather than the

⁴ We use the term “economic bottleneck” through this document to mean not just parts of the network where BT has significant market power (SMP), but those areas where effective, infrastructure-based

core network. This would suggest a focus on regulating access and interconnection at the MSAN rather than at the Metro node.

- 3.9 However, it is not possible to draw a simple boundary between that part of the network which is an enduring bottleneck and that which is competitive. Backhaul in particular might be regarded as having the potential to be competitive, and not therefore an enduring bottleneck, but is not currently particularly competitive. This raises particular challenges for regulation, due to the need to make regulated backhaul services available to other operators, but to do so in a manner that does not disincentivise the development of a competitive backhaul market.
- 3.10 This boundary may also be different in different geographies, as recognised by the fifth regulatory principle. This geographic variability is due to variability in the number and type of customers served by MSAN sites, and variability in the competitive supply of backhaul, as discussed in more detail below
- 3.11 It will therefore be necessary to consider the provision of access at both the local and metro geographic level. Ofcom does not however consider it necessary explicitly to consider the question of access at core nodes, since if there is effective competition at the other levels, then there will also be effective competition at core nodes.

Question 1. *What are your views on potential for competition based on access at different geographic levels (local/metro/core) and the way this may vary depending on geography?*

Service layer depth

- 3.12 Secondly, it is also necessary to consider which service layer of 21CN should be the primary focus of regulation. The service layer options can be thought of as running from physical access (eg local loop unbundling) through generic conveyance (eg bitstream interconnection), service-specific interconnection services (e.g. voice call origination) to end-to-end wholesale products (eg end-to-end voice calls). The Open System Interconnection (OSI) reference model is also a useful model to illustrate the differences in depth of service layer (see Table 2).

competition is unlikely to emerge in the medium term. This may be due to the fundamental economics of building competing infrastructure, or in some cases due to market factors such as barriers to customers switching suppliers

Table 2: OSI Reference model

	OSI layer	Example access (note correspondence with OSI layer is approximate and illustrative only)
7	Application	End-to-end voice calls
6	Presentation	
5	Session	Call control interface (eg using SIP)
4	Transport	Bit stream with end-to-end QoS
3	Network	Bit stream (layer 3) routed IP
2	Data link	Bit stream (layer 2), eg ATM, Ethernet
1	Physical	Access to copper loop

3.13 In general, the deeper within this stack that access is made available, then the greater the scope for value add and innovation by alternative providers. Consistent with its regulatory principles, Ofcom believes competition should be promoted as deep in this service stack as possible. For example, where it leads to effective and sustainable competition, physical access would be preferred to bit stream or service specific access.

3.14 An important implication of focussing on deeper service levels is that access products supplied at a lower service levels need to be capable of supporting the provision of services at higher levels. For example, a generic bitstream interconnect product would in principle be preferable to a voice specific interconnect product. However, for a generic bitstream product to enable competition in voice services it would have to provide adequate quality of service (including, for example, an acceptable level of delay), in order for the voice services built on it to compete effectively. Similar issues might be raised by future multimedia services (e.g. real time video), as discussed in section 5.

3.15 The possible combinations of geography and service layer in the 21CN architecture are illustrated in the table below.

Table 3: Combinations for geographic and service level access

Service level	MSAN/MDF sites	Metro nodes
Physical unbundling	Yes	No
Bitstream interconnection	To be considered	Yes
Service-specific interconnection (e.g. PSTN voice)	To be considered	Yes

3.16 BT’s initial 21CN plans are to offer physical unbundling at the MDF/MSAN nodes, and interconnection (both bitstream and service specific) at metro nodes. As discussed in more detail below, Ofcom has some concerns as to whether this range of options will

support 'equality of access' at the deepest level possible, and is therefore of the view that some form of interconnection at the MSAN also needs to be considered.

- 3.17 In addition, different levels of access might be appropriate for different types of providers. For example, a provider of a competing next generation network may need to interconnect with BT's 21CN, or they may need access to underlying network infrastructure. In contrast a service provider whose main focus is on providing value added services might seek a higher level interface at the application layer of BT's 21CN, but may also be able to obtain access on a commercial basis to the application layer of competing NGNs. Such 'differentiated access' is illustrated in figure 3 below.

Figure 3. Differentiated access for competing NGNs and value added service providers

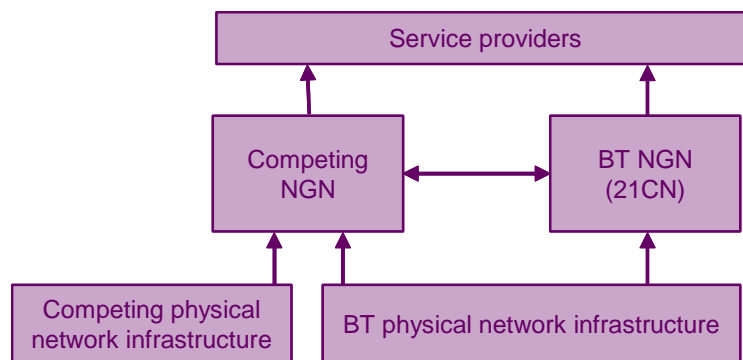

Principle 2: Equality of access

- 3.18 The overall objective for equality of access is that where BT is required to provide a wholesale product because of its SMP in the relevant market, then all customers for this product must be treated in exactly the same way in all respects irrespective of whether the customer is an external customer or an internal BT customer. This is most critical at the deepest point where competition is effective and sustainable as discussed above. Section 6 and Annex G of the Telecoms Review set out Ofcom's thinking on equality of access in more detail.

- 3.19 Equivalence has a number of dimensions. The three key areas are:

- **Product:** including the features, functionality and quality of service of the wholesale product
- **Process:** including the processes for forecasting, ordering, provisioning and fault repair of the wholesale product
- **Price:** covering the price of the various aspects of the wholesale product

- 3.20 These are not static requirements, however. It is also important that there is equivalence throughout the product development and in-life management life cycle. Equivalence implies that all BT's wholesale customers (rival operators as well as BT's own retail operations) have the same ability to influence changes or have problems addressed; for example in provisioning, fault management and billing.

- 3.21 Reduced time to market for new services is one of the key benefits of 21CN and NGNs in general. Therefore, a further aspect of equivalence which is specifically important for 21CN will be an effective and transparent process for the introduction of new products.

3.22 There are two models of equivalence, described in Chapter 6 of the Telecoms Review as “equivalence of outcome” and “equivalence of input”:

- Equivalence of outcome implies that the wholesale products that BT offers to its wholesale customers should be comparable to those that it offers to its own retail activities, but the product and processes need not be exactly the same so long as any differences are not material. This type of equivalence can be applied with different levels of rigour.
- Equivalence of input means that BT’s wholesale customers are able to use exactly the same set of regulated wholesale products, at the same prices and using the same systems and transactional processes, as BT’s own retail activities.

3.23 Ofcom’s view is that equivalence of input should be adopted when the cost is proportionate, such as for all new wholesale products, processes and systems. This is likely to encompass any new services that BT is required to provide over 21CN in markets where BT has SMP.

3.24 In the context of 21CN, specific examples of equivalence issues raised are:

- At the local level, whether migration processes from narrowband to broadband using local loop unbundling can be equivalent to broadband dial-tone
- For voice services, whether the introduction of new interconnection arrangements, and the associated withdrawal of DLE interconnection, will support full equivalence for all call types.
- For intelligence capabilities, how equivalent access to network hooks can be provided.
- The ability of BT’s next generation operational support systems (OSS) to support equivalence of input.

3.25 For legacy services, where the cost of adopting equivalence of inputs may be greater, Ofcom’s view is that equivalence of input should be used sparingly, and only at specific levels in the value chain. This is therefore only likely to affect a subset of the current regulated wholesale products. However, 21CN will be relevant to all legacy products, since even the weaker form of equivalence (equivalence of outcome) is likely to require product changes in light of new capabilities introduced by 21CN (product-specific issues are covered in Section 6).

Principle 3: Regulatory withdrawal

3.26 Ofcom’s third proposed principle is that we should withdraw from regulation as soon as competitive conditions allow. There are two distinct reasons why 21CN might allow for regulatory withdrawal:

- 21CN may be the vehicle for the delivery of improved equivalence in relation to BT’s wholesale services. This should allow other providers to compete in downstream markets and would create the conditions where BT’s downstream services, particularly at the retail level, could be deregulated.
- At the wholesale or network level a key theme of 21CN is convergence. If convergence is effective, this should allow a reduction in service specific wholesale regulation, and a greater focus on generic access and interconnection remedies (for example LLU, bitstream interconnection).

3.27 Together these would help regulation become more focussed but also more effective, Reducing the layers and complexity of regulation should help all market players, for

example by reducing the regulatory costs and risks faced by alternative providers as well as BT.

Regulatory withdrawal as a result of improved equivalence

- 3.28 The idea that withdrawal of downstream regulation might be possible following the introduction of an effective wholesale access remedy is well established. WLR was introduced on the basis that the downstream market (retail calls and access) would be deregulated once WLR is 'fit-for-purpose', whilst Ofcom's work on large business pricing introduced the concept of downstream deregulation based on 'replicability'. However, whilst the concept is generally accepted, it has had little practical impact, due to the lack of equivalence offered by the current set of regulated wholesale products. If 21CN enables effective equivalence, then this may in turn enable deregulation of downstream retail markets.
- 3.29 In addition, a general move towards 'equivalence of inputs' might also allow some simplification of current wholesale regulation. This regulation tends to be complex because of the lack of equivalence in the relationship between BT's wholesale and retail activities. If, for example, BT's retail activities purchased wholesale services using the same systems and processes as other providers, then the requirement to publish an extensive set of Key Performance Indicators (KPIs) in order to demonstrate non-discrimination might be reduced.

Question 2. *In what areas might regulatory withdrawal be feasible if 21CN enabled the delivery of improved equivalence, including 'equivalence of inputs'?*

Regulatory withdrawal as a result of convergence

- 3.30 A key theme of NGNs is convergence, and this makes possible a vision of the world in which we move from regulating:
- many service specific access products at multiple levels (both geographically and service levels) in the network available in all geographies, to
 - a small number of more generic access products.
- 3.31 This process is illustrated in Figure 4 below. Specific examples might be:
- a generic bitstream access product to be used for voice and data services (the implications for voice services are discussed further in section 5);
 - a generic bitstream backhaul product to carry traffic from all services types, eg voice, consumer broadband and corporate services, with control over the quality of service offered to different traffic types.

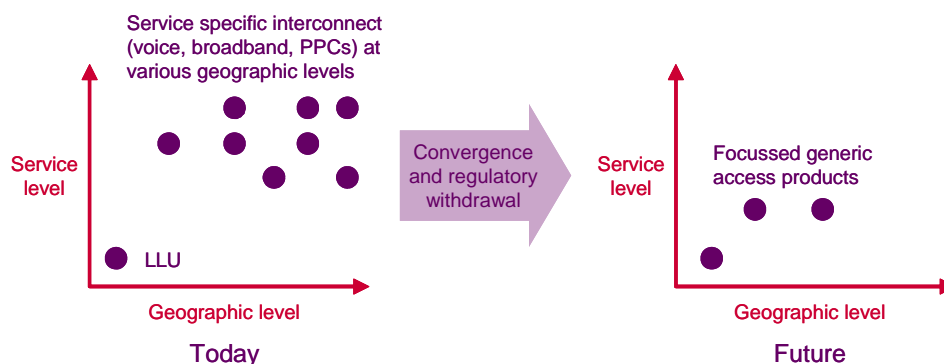
Figure 4. Regulatory withdrawal as a result of convergence (illustrative only)

Question 3. *What opportunities are there for generic access products to enable withdrawal of regulation from existing service specific products?*

3.32 This depends on focusing on the right generic products and withdrawing the service specific products where possible. In terms of generic access, three main options have been discussed above: physical unbundling, generic access at MSAN, generic metro node access. Although all three may be appropriate in particular geographies and particular times, to regulate all three in all geographies indefinitely would be inconsistent with our intention to focus regulation on enduring economic bottlenecks only. For example, it might be inappropriate to regulate physical unbundling and bitstream interconnection at the same MDF/MSAN site. On the other hand, it may be difficult to identify precise geographic boundaries for each individual access option without prejudging how the market will evolve in particular areas.

3.33 A regulatory approach to achieve focus, whilst avoiding the risks and complexities of trying to predict the market at a very granular level might be:

- Initially for all options to be available at all locations where there is not yet evidence of effective competition
- Lighter regulation, for example a non-discrimination rule, to be applied to downstream services, ie MSAN and metro node access, in geographies where evidence that competition is already developing (for example where alternative providers have begun unbundling loops)
- Regulation of downstream products to be withdrawn in geographies where there is evidence that effective competition has developed.

Question 4. *What approaches should be considered for focusing regulation on enduring economic bottlenecks?*

3.34 If this approach is effective it may be possible eventually to withdraw service-specific regulation, in relation to services such as voice and leased-lines. This issue is discussed in more detail in Section 5.

Principle 4: A favourable climate for investment

3.35 Ofcom's fourth proposed principle is to promote a favourable climate for efficient and timely investment and stimulate innovation, in particular by ensuring a consistent and transparent regulatory approach. In applying this principle to NGNs, it is important that

regulation should not simply be seen as a 'zero-sum' game, where Ofcom's primary concern is to decide how the benefits of BT's investment in 21CN should be divided between BT and the rest of industry. Instead, the aim should be to promote a favourable investment climate for industry as a whole, in order to deliver the greatest possible benefit to consumers of an industry wide migration to NGN.

- 3.36 There are a number of ways in which Ofcom can influence the investment climate, although their relevance to BT and other providers varies:
- Regulatory clarity and predictability (relevant to all providers)
 - Confidence in wholesale products (relevant to alternative provider's investment)
 - Regulated returns (more relevant to BT)
 - Migration to 21CN
- 3.37 Firstly, and perhaps most importantly, Ofcom should minimise the regulatory risk faced by all providers by providing clarity and predictability as to the regulatory obligations likely to apply to NGNs. This is one of the key aims of this consultation and of Ofcom's ongoing dialogue with BT and other providers.
- 3.38 Secondly, other providers need to have confidence that economic bottlenecks associated with BT's 21CN are addressed through the availability of appropriate access and interconnection products. Again, one of the outputs of this consultation should be the identification of these economic bottlenecks and the possible products needed to address them. In addition, providers need to be confident that these products will enable them to compete - this is the key driver behind Ofcom's proposals for equivalence.
- 3.39 Thirdly, Ofcom's approach to setting BT's returns for regulated products is crucial to investment incentives. As set out in Section 7 of the Telecoms Review, we believe that there are three core considerations:
- the technical, financial and market risks faced by BT when making its 21CN investments
 - the scope for investment by competing providers, so that regulating BT's returns does not harm the development of competition where it is in prospect
 - the need to protect consumers from excessive charging.
- 3.40 One of the most significant ways in which Ofcom currently controls BT's returns is through the Network Charge Controls (NCCs) in a number of wholesale narrowband markets. Ofcom is currently working on a new set of NCCs, to take effect from September 2005 and will be consulting on detailed proposals, including the trade-off between the factors outline above, in February 2005. Ofcom could also take account of the risk attaching to new investments in risky assets relative to stable legacy assets by applying a different estimate of the cost of capital for such investments. We will be consulting on our approach to the assessment and accommodation of risk in regulatory decisions shortly.
- 3.41 Fourthly, Ofcom can facilitate the migration from the existing set of regulated products to the new set of 21CN products. The aim would be to minimise the adverse impact on investments in existing regulated products (and thereby minimise the perceived risk associated with future investments) whilst ensuring there is not an extended period of parallel running (which is relevant to BT's 21CN investment). Two specific areas where Ofcom may have a role:

- There are some regulated wholesale products that are likely to be rendered obsolete by 21CN (for example FRIACO – see Section 5). Ofcom would hope to ensure that the regulatory obligations in relation to such products are withdrawn in a manner which recognises the risk of stranded assets for alternative providers whilst ensuring that switch off is not delayed unnecessarily.
- There are a number of legacy products which are likely to have a 21CN equivalent, but where this equivalent may not support the full range of legacy services. For example, it may not be cost-effective for BT's PSTN replacement service to support all the legacy variants of ISDN that are currently supported. Changes are likely to be required to the product specifications of a number of regulated products. Ofcom would hope to ensure that any changes are timely, whilst taking account of the impact on other providers.

3.42 The general issues for 21CN migration are considered further in the next section.

Question 5. *What principles should Ofcom adopt in order to promote a favourable climate for efficient and timely investment in Next Generation Networks?*

Access at the local access network level (MDF/ MSAN site)

3.43 At the MDF/ MSAN site there are two main alternatives for the provision of access:

- Access to the physical copper, ie local loop unbundling (LLU)
- Some form of interconnection with the MSAN (possible options for MSAN interconnection are explored below)

Figure 5. Alternative approaches to access in 21CN

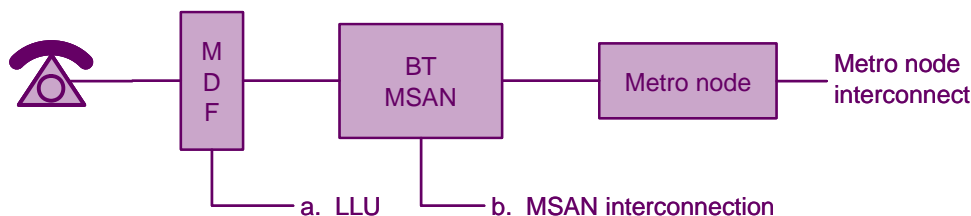

3.44 Applying the first regulatory principle, Ofcom would favour the deeper option, ie LLU, where this can lead to effective and sustainable competition. However, two factors suggest that an alternative to LLU, ie some form of interconnect with the MSAN, should be considered, at least in some areas, as a more effective means of promoting competition at this level.

- The challenge for LLU migration processes raised by BT's deployment of 'broadband dial-tone'
- LLU is unlikely to be viable in all geographies, particular in those areas (eg rural areas) where there is a lower number of households connected to each MDF site. But if metro interconnect is the only option where LLU is not viable, any potential for competition in backhaul would be eliminated.

Question 6. *Do you think that there may be demand for products offering access at the MSAN in addition to or as an alternative to LLU? Are there relevant issues other than LLU migration processes and enabling backhaul competition?*

Broadband dial-tone and LLU migration

- 3.45 BT's stated target is to ensure that, by 2009, 'broadband dial tone' is instantly available to most BT customers in the UK. Consumers will be able to plug a broadband device into their phone line, and immediately be able to subscribe to BT's broadband service just as they can turn on 'Select Services' today. Ofcom understands this will be achieved by migrating existing narrowband customers onto MSANs with line cards which will be capable of simultaneously supporting narrowband and broadband services (sometimes known as combination or "combi cards").
- 3.46 However, whilst seamless migration from narrowband to broadband is in itself clearly beneficial for consumers, it could create a major challenge for LLU-based operators and competition at this level because at the heart of current generation LLU is a manual migration process. Equivalence for LLU might be possible as long as BT is also using a manual migration process, but it will be a challenge for a manual migration process to continue to provide equivalence once 'broadband dial tone' is widely available.
- 3.47 Possible options, illustrated in Figure 6 below, might include:
- Re-engineering the current manual migration process to reduce provisioning timescales. This is likely to be the simplest option, and may deliver 'near-equivalence' compared to broadband dial-tone, but provisioning timescales are likely to be a few days at best.
 - Replacing the current manual migration process by an automated process using a copper cross-connect in front of the MSAN (probably some form of electro-mechanical switch). This would address the migration issue, whilst retaining the key benefit of LLU (an ability to innovate by deploying a separate MSAN). However, electro-mechanical switches tend to be less reliable and less scaleable than electronic switches, and practical experience with copper cross-connects to date has been poor.
 - Replacing the current manual process by a form of access at the MSAN that could enable operators to take over a BT line by taking control of the associated line card in BT's MSAN ('soft LLU'). Operators would then pick up the associated transport stream using some form of bitstream interconnection. The main disadvantage with this approach is that the use of a shared MSAN limits the ability of operators to innovate. This might however be minimised if some means was found of providing alternative providers with an ability to configure line cards independently of each other, based on some sort of 'operator profile' (cf 'Project Pronto'⁵ in the US).

⁵ Project Pronto was associated with an exception granted by the Federal Communications Commission to the merger conditions for SBC / Ameritech in September 2000.

Figure 6. Approaches to next generation local loop unbundling

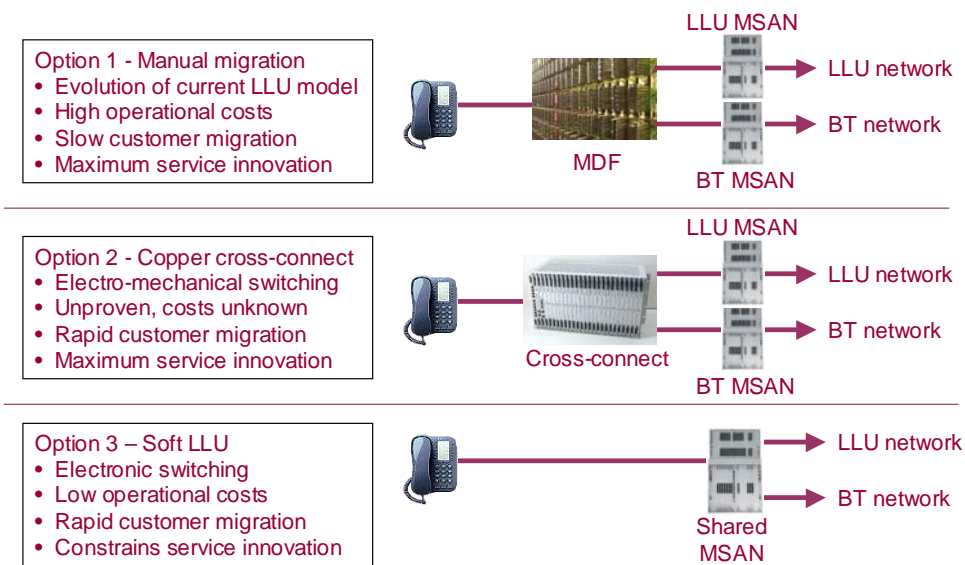

Question 7. What is the potential impact on LLU operators and competition in broadband access of the widespread availability of broadband dial-tone?

Question 8. Is it likely to be sufficient for LLU operators to have ‘near-equivalence’ compared to broadband dial tone, and if so, how short must provisioning timescales be?

Question 9. What is the shortest provisioning timescale that might reasonably be delivered by a re-engineered manual migration process for LLU? If a re-engineered manual migration process is likely to be inadequate, then what alternative means should be considered to ensure operators can compete on an equal basis with a broadband dial tone (eg copper cross-connect, ‘soft LLU’)?

Question 10. If some form of ‘soft LLU’ was made available, might it be practical to provide alternative providers with an ability to configure line cards independently of each other, based on an ‘operator profile’?

Backhaul competition

3.48 In geographies where LLU does not lead to sustainable competition, the result of having metro node interconnection as the only other option is to bundle access and backhaul services. However, if there is potential for effective and sustainable competition in backhaul services in locations where LLU is not viable, then applying Ofcom’s first principle (promote competition at deepest level), some form of interconnection with the MSAN may be preferable to interconnect at the Metro node.

3.49 MSAN interconnect might therefore extend the potential for competition in backhaul services if:

- The costs of MSAN interconnect meant that it was viable at exchanges where LLU was not; and

- There was potential for a competitive supply of backhaul at those exchanges;
- 3.50 Four possible scenarios based on these factors, with corresponding access and interconnection options (1-4) for each scenario, are summarised in Table 4 below.

Table 4: Scenarios for access and interconnection

	Competitive supply of backhaul possible	No potential for competitive supply of backhaul
Economics of MDF support LLU	1.LLU with competitive backhaul	2.LLU with regulated backhaul
Economics of MDF mean that LLU is not viable, but MSAN interconnect is	3.Interconnection at MSAN	4.Interconnection at Metro node

- 3.51 At a simple level, whether or not MSAN interconnection is economically viable at exchanges where LLU is not, is likely to be influenced by two main factors:
- **Utilisation benefit.** At smaller exchanges where LLU operators cannot achieve sufficient scale, interconnection with a shared (BT owned) MSAN may be more efficient than multiple MSANs owned by different operators.
 - **Interconnect cost.** Enabling MSAN interconnect may introduce additional costs, both at the MSAN site and more widely (for example in OSS), compared to a design where all traffic is routed to BT. Clearly, interconnect cost will be dependent on the form and complexity of interconnect used (see below for consideration of different types of MSAN access).
- 3.52 However, Ofcom recognises that the overall effect of these factors is complex, and that operators are in the best position to be able to assess whether a form of MSAN interconnection would be commercially attractive and therefore offer the potential for increasing backhaul competition.

Question 11. *To what extent, and over what timescale, might operators realistically build out their own networks to the MDF/MSAN nodes, thereby enabling a competitive market in backhaul services?*

Question 12. *Are there parts of the UK where backhaul between MSAN nodes and Metro nodes should be regarded as an enduring economic bottleneck?*

Question 13. *Might MSAN interconnection enable sustainable competition in backhaul in geographies where LLU is not viable?*

Level of access

- 3.53 As discussed above, access can be considered to vary in terms of service level as well as geographic location. It is therefore important to consider at which service level

access might be provided at the MSAN. At a high level, a number of options could be envisaged, for example:

- ‘Soft LLU’. Handles all types of traffic and operates at the data link level, ie layer 2 in the OSI model (see Table 2), for example so that all traffic from a particular line card is directed to a specific output operator.
- Bitstream interconnection. Handles all types of traffic and operates at the network level, ie layer 3 in the OSI model, for example where packets might be routed differently on a packet by packet basis.
- Voice interconnection. Deals with voice traffic only, and may, for example have a signalling gateway between the MSAN and the interconnecting operator’s call server.

3.54 Ofcom’s regulatory principles point to an access solution at the deepest possible service layer, eg ‘soft LLU’. Access at the deepest layer may also be least costly if it involves the least additional functionality supported by the MSAN (compared to an MSAN with no access capabilities at all). For example, ‘soft LLU’ provided at the data link layer of the OSI stack should be cheaper than bitstream interconnection provided at the network layer, as there is no need to route packets based on final network destination. This would fit with BT’s current plans not to support dynamic routing of IP traffic at the MSAN. Service specific (eg voice) interconnection at the MSAN might incur significant additional costs if service specific functionality (eg a voice gateway) were provided at every MSAN, and therefore may not be cost-effective to provide.

Question 14. *Is it likely to be cost-effective for MSANs to support dynamic routing of IP traffic, and if not, what alternative options should be considered for providing some form of MSAN interconnection?*

Question 15. *If MSAN interconnection were appropriate, what level of access (eg layer 2 v layer 3 v voice interconnect) is likely to be suitable?*

Question 16. *Is it possible to rule out at this stage the option of providing service specific interconnect at every MSAN?*

3.55 Ofcom understands that BT plans to deploy MPLS technology within its core network, including the metro nodes, but that BT does not currently plan to deploy MPLS within the backhaul network which conveys traffic between the MSAN and metro nodes. If some form of MSAN interconnection is made available, then it will be necessary to consider how end-to-end QoS management can be supported.

Question 17. *Given that MPLS technology is only likely to be deployed within core networks, at least for the immediate future, how might services based on some form of MSAN interconnection provide adequate quality of service?*

Equivalence of input

3.56 An MSAN interconnection product would also need to support “equivalence of input” as discussed above, ie an identical product would be used by BT as an input to its own services. Based on Ofcom’s current understanding of 21CN, some illustrative implications of applying equivalence of input to such a product are shown in Table 5.

Table 5: Examples of equivalence of input for MSAN interconnection

Example BT use of MSAN interconnection product	Equivalent Altnet use of MSAN interconnection product
BT interconnects its backhaul fibre with the MSAN conveys all traffic from all its connected subscribers to its metro node.	Altnets interconnects its backhaul fibre with the MSAN conveys all traffic from all its connected subscribers to its metro node (or equivalent).
MSAN interconnection supports a wide range of access types, eg <ul style="list-style-type: none"> - POTS - Asymmetric broadband access - Symmetric broadband access 	Altnet have access to same range of access types
Combined POTS / DSL cards allow BT to nearly instantly enable broadband services ('broadband dial-tone') for their subscribers	Same capability is available for Altnets

Question 18. *What are the aspects of equivalence of input that would need to be considered for MSAN interconnection?*

Access at the core network level (Metro node)

3.57 In more rural geographies access at the metro node may be the deepest level at which competitive can be effective and sustainable. Currently some Altnets physically connect to over 100 of BT's existing sites and it is therefore conceivable they will be able to connect to all of the 21CN metro nodes. This suggests that inter-metro node conveyance is potentially competitive, and that regulation should be focussed on origination to the (first) metro node rather than distant metro nodes.

Figure 7. Interconnect at first and distant metro nodes

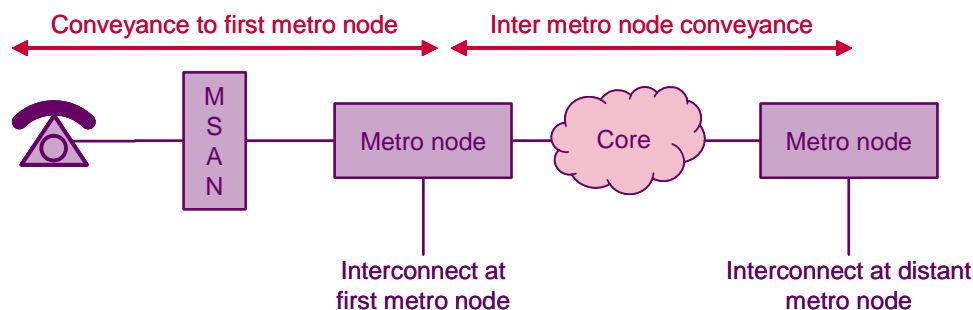

3.58 However, in moving to 21CN there are two key differences for metro nodes which might, albeit temporarily, lessen competition at this level. Firstly, metro nodes are at a greater number of locations than existing tandem exchanges (although less than DLEs), with the implication that some of the new metro nodes could be in more rural areas compared to existing tandem exchanges.

3.59 Secondly, although Altnets are currently located at many of BT's current switching sites, many 21CN metro nodes are at physically different locations. The arrangements

offered by BT to deal with the closure of existing interconnect sites will influence the impact of this change on competition (this issue is considered further in section 4)

Question 19. *Do you believe that inter metro conveyance is not an enduring economic bottleneck and therefore, where LLU/MSAN access competition is not viable, that regulation should be focussed on access at the first metro node?*

Question 20. *Is the ability of operators to build out to metro nodes likely to vary geographically, resulting in the need for conveyance to some nodes to be regulated on an ongoing basis?*

Question 21. *What would the characteristics be of a metro node access product supporting equivalence of input?*

Access to intelligence functionality ('network hooks')

- 3.60 The access mechanisms discussed above focus on conveyance, which is traditionally the way in which control over the last mile can have an impact on the development of competition. However, it is also appropriate to consider the issues raised by other forms of access and whether NGNs will create new economic bottlenecks which providers will need access to in order to compete effectively.
- 3.61 For example, an alternative provider may be able to deliver a voice service based on the use of bitstream access, but they may need access to additional functionality at the application layer in order to be able to compete effectively. These functions, for which there is not always a clear equivalent in the PSTN world, are sometime referred to as 'intelligence capabilities' or 'network hooks'. Examples include:
- Authentication
 - Presence and Location
 - Directory and profile
 - Call prioritisation (standard call preference markers)
 - Secure connections
 - Quality of Service management
 - Digital Rights Management
- 3.62 Many, perhaps most, intelligence capabilities may be replicated by interconnecting communications providers who could build equivalent systems. However, there may be capabilities that cannot be replicated because they rely on information or control that is not available to the interconnecting operator. Historically some of these capabilities have been 'hard-wired' into the network (e.g. onward routing for number portability), but they might be expected to migrate to the intelligence layer of NGNs. The following are possible examples:
- 'Location and presence capability'. This could allow the identification of the physical access connection and hence geographic location of a user or device. It might also record the last known location that the user connected to the network. This would allow fixed network operators to offer services with some of the characteristics of mobile services, supporting the general trend towards fixed-mobile convergence

- ‘Connectivity resource’ capability. This may allow the dynamic establishment of a virtual connection with particular characteristics, say bandwidth and delay. This could be used for example to provide an on demand bandwidth boost for streaming of high quality video.
- ‘Connection information’ capability. This could provide information about the type of connection the user currently has, for example its maximum supported bandwidth, contention and perhaps information about congestion or delay on that route. This information might allow other providers to dynamically choose which services to offer the customer or what compression technology to use.
- ‘Address resolution’. This would be needed to translate a logical address (e.g. a telephone number) to a network location (e.g. an IP address), or to translate one network location to another (e.g. for NTS services, number portability).

3.63 For each intelligence capability, there are potentially three different ways in which access to intelligence capabilities it could be treated:

1. Where BT has control of functionality or ownership of data because of SMP in a related market, for example due to its control over the access network, there might be an access obligation that relates only to BT’s 21CN.
2. Reciprocal access might be required if access to a capability is necessary in order to fulfil a regulatory obligation that applies to many providers (for example relating to number portability or call termination).
3. Reciprocal access might be provided on a voluntary commercial basis, with no regulatory involvement.

Question 22. *Under what circumstances should BT face specific access obligations for intelligence capabilities due to its SMP in a related market and what specific examples are there?*

Question 23. *Under what circumstances should access to intelligence capabilities be regulated on a reciprocal basis and what specific examples are there?*

Question 24. *To what extent might commercially negotiated access to intelligence capabilities remove the need for regulation?*

3.64 The principle of focussing regulation at the deepest level also applies in the context of potential new economic bottlenecks. For example, access to intelligence capabilities might be made available via a high level open API (e.g. Parlay, Parlay X, Web Services) to application service providers. However, a deeper ‘hook’ into the network, to allow direct access to a capability, could avoid other providers having to duplicate the intelligence functionality that they can provide themselves, and potentially provide greater functionality and control.

Question 25. *Is it important to consider the provision of deeper hooks to directly access intelligence capabilities and is this access likely to be practical?*

Systems and processes

3.65 As discussed above and in the Telecoms Review, a key aspect of ‘equality of access’ is a shift, where practical, from ‘equivalence of outcomes’ to ‘equivalence of inputs’. The intention is that alternative providers should be able to order and manage key access and interconnection services using the same processes and systems as are used by BT’s retail activities (BTR). The strategic review proposes that ‘equivalence of inputs’ should apply to new access and interconnection services associated with 21CN, where those services are the result of a regulatory obligation, as well as to certain key legacy services.

Next generation OSS

3.66 The main practical challenge in relation to delivering ‘equivalence of inputs’ is the structure (monolithic, vertically integrated) and complexity (~1300 different systems, proprietary interfaces) of BT’s legacy Operational Support Systems (OSS). However, a key element of BT’s 21CN is the evolution of this legacy OSS to a ‘Next Generation OSS’, and this creates a significant opportunity to deliver ‘equivalence of inputs’ in a cost-effective manner.

3.67 BT’s plans for implementing a Next Generation OSS comprise a distributed OSS architecture, based on off-the-shelf commercial systems linked by standard industry interfaces. This is expected to replace the vertically integrated OSS systems currently in use.

3.68 The migration path being used by BT depends on the use of a common ‘hub’, which links the new sub-systems to each other, as well as to the legacy systems. This allows a gradual migration of functionality out of the legacy, vertically integrated system, and into the new distributed architecture (see Figure 8).

Figure 8. Migration path for operational support systems

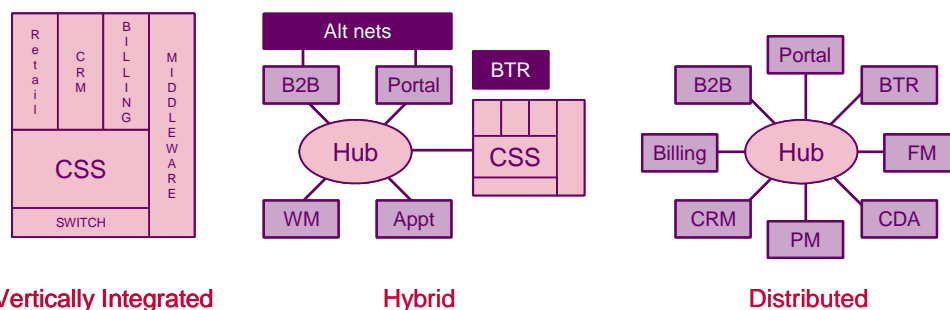

3.69 This distributed architecture lends itself to ‘equivalence of inputs’ much more readily than the legacy OSS. However, there are still two possible models. In one model, the new approach results in a set of systems within a ‘walled garden’, with BT’s retail activities on the inside of the wall and others outside. However, equivalence of inputs requires BT’s retail activities to be on the outside, using the same B2B systems as the Altnets. These two models are illustrated in Figure 9.

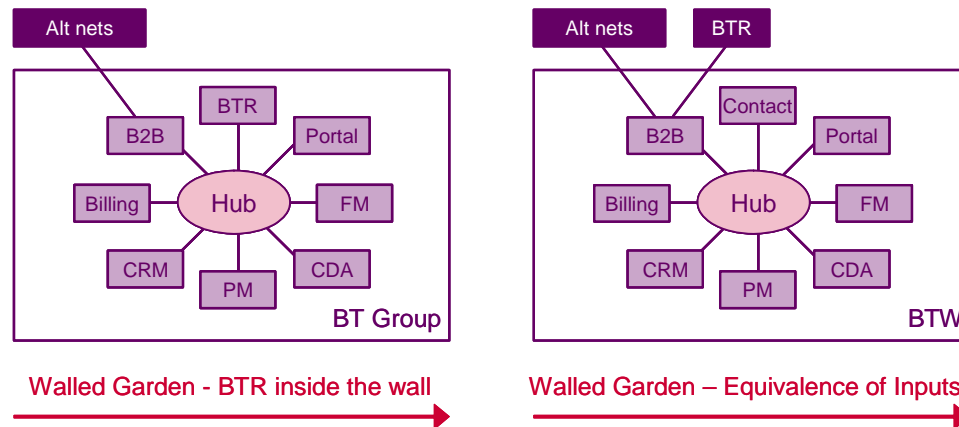
Figure 9. Possible models for next generation OSS

3.70 Although Ofcom has a preference for Equivalence of Inputs, and believes that the new architecture does lend itself to such a model, Ofcom also recognises that there may be a number of practical barriers to delivering it. These include:

- o Scale. Current B2B gateways may not support the volume of transactions between BTR and BT's wholesale activities (BTW).
- o Security. Security must be maintained, and this will require the development of appropriate access and authentication measures.
- o Standards support. Although there is consensus on the basic approach to B2B systems (XML), detailed messaging standards are still evolving.

Question 26. *What might be the benefits from achieving equality of access to 21CN OSS, and do these require adoption of 'equivalence of inputs', or is some form of compromise appropriate?*

Question 27. *What might be the practical barriers to achieving 'equivalence of inputs' in relation to 21CN OSS, and do you believe that these are likely to be surmountable?*

Section 4

Transition to the new world

Introduction

- 4.1 The previous section has considered the implications of Ofcom's proposed regulatory principles for NGN access and interconnection. However, in moving to new access arrangements it is important to consider the transition from existing arrangements that have been established over many years. This section outlines the issues raised by this transition and discusses possible guiding principles.
- 4.2 The transition issues specifically related to 21CN generally divide into issues associated with product migration (eg ATM to IP, voice VPNs to IP VPNs) and issues associated with geographic rearrangement (eg removal of DLEs, new sites for metro nodes). Although the issues raised by the different migrations vary, we think it is first important to consider the possible guiding principles for transition in general.

Guiding principles

- 4.3 Any principles should recognise that many providers have already made significant investments based on the current arrangements, but also that ultimately new arrangements could, if designed properly (the subject of section 3), benefit all: BT, other providers and of course consumers. However, there is potential for tension between these aims, for example at one extreme keeping existing arrangements indefinitely, at the other moving immediately to new (more efficient) arrangements.
- 4.4 As technology advances, all providers in competitive markets are likely to need to invest in new technology in order to remain competitive. Therefore, it is unlikely to be appropriate to preserve existing arrangements indefinitely, or to aim to protect providers from technical obsolescence. However, this must be balanced against the fact that it is BT's initiative that is driving potential changes in access products now, ahead of most other operators in the world, and other providers may not have such a strong business case for such an early migration to an NGN.
- 4.5 Possible guiding principles for the transition include:
 1. The transition process should be transparent, predictable and carefully managed so that all providers can control the risks associated with new and existing investments (management of the transition process is discussed further below)
 2. Transition should minimise the total costs to all parties, including BT and other operators. For example, it should clearly take into account the costs of parallel running, but also the costs imposed on competing operators of an early migration.
 3. Transition should minimise any negative impact on customer experience. In particular, wholesale products must be migrated in a manner that is as far as is practical invisible to end-users.
 4. Transition should minimise the impact on investments based on existing regulated products, particularly investments which are sunk. As well as impacting the return on those historic investments, unexpected changes now could

increase the perceived risk of future investments and therefore reduce future investment.

5. Where new arrangements are made available in addition to existing arrangements, so that providers have a choice, then it is beneficial for these to be introduced as soon as possible.

Question 28. *What do you believe the appropriate guiding principles should be for the transition from existing access and interconnection arrangements to new arrangements? Do you agree with Ofcom's proposed principles?*

Product migrations

4.6 We expect 21CN to require a number of product migrations. Although it may be possible for 21CN to continue to provide many or most existing regulated products, it is unlikely the product set will remain static for a number of reasons.

- The cost and complexity of supporting some legacy regulated products and features may be very high. In these cases, the most efficient option may be a carefully managed withdrawal of the product (taking into account the principles above)
- Where existing regulated products can continue to be provided (perhaps through some emulation), it may ultimately be less efficient to provide them compared with new products that are more closely aligned with the underlying technology. For example:
 - low bandwidth leased lines being replaced by higher bandwidth leased lines or virtual IP capacity;
 - dial-up Internet access, perhaps ultimately being superseded by low bandwidth always on IP
 - voice VPNs being superseded by IP VPNs
- There is a change in the underlying network technology used to provide a regulated product, for example from traditional SDH leased lines to Ethernet and from ATM to IP/MPLS.

4.7 These changes may mean that the appropriate regulated access products in a number of markets will need to evolve, as might the market structure, and the process for managing that transition is considered in more detail below. Each change is likely to be complex in terms of the issues and transition process and this is discussed in more detail below. Some service specific changes are considered in more detail in Section 5.

Question 29. *What types of product migrations are there likely to be for 21CN and what general issues do they raise?*

Geographic rearrangement

4.8 21CN will also lead to substantial geographic rearrangement of networks. This is likely to be more contentious than product migrations, since the benefits are asymmetric. A key goal of competition policy over the last 20 years has been to encourage competition in conveyance services, by providing incentives for alternative operators to

build out to as many points of interconnection with BT as possible. This has been successful, particularly in relation to voice conveyance. However, many of the points of interconnection to which other operators have deployed may no longer be available within 21CN, for two reasons. Firstly, 21CN is a much flatter architecture than existing networks with a simpler hierarchy of nodes and fewer nodes in total (notably interconnection at local exchange level will not be possible because there will be no equivalent of local exchanges). Secondly, BT's current plans are for many of its new metro nodes to be on green field sites at which no operator will currently be connected. Unlike the product migration, whilst BT may benefit from this change, alternative providers could face significant costs.

4.9 It would clearly not be appropriate for Ofcom to determine the locations of BT's network nodes. However, it is important that BT takes account of the costs imposed on alternative providers when re-arranging its network. For example, this might be achieved through:

- Continued provision of interconnect at existing sites, with BT conveying Altnet traffic to and from the new interconnect sites.
- Compensation for the costs incurred by Altnets in rearranging their network to new points of interconnection. Where Altnets have laid fibre to existing points of interconnect, the business case for doing so will in general relate not just to current interconnect capacity, but also to future capacity, and there should be some recognition of this in the size of any compensation payment.

4.10 Ofcom would prefer that the level, form and period of compensation is resolved through commercial negotiation, with the principles proposed above as a guide. However, Ofcom is aware that there have been delays in the first stage of this process, namely the communication of metro node locations to other providers. We would hope that commercial negotiations can be progressed more quickly in the future, however, should this process fail, we would be prepared to become more directly involved.

4.11 The other impact of geographic changes will be on the structure of existing charges for regulated products. In particular, regulated narrowband call products are currently based on there being three different levels of conveyance (call origination to the DLE, local-tandem conveyance, and inter-tandem conveyance), and this will change as a result of 21CN. The implications for regulated charges are however being examined in Ofcom's forthcoming review of the network charge controls and are not considered further here.

Question 30. *What might be the impact of geographic migration of points of interconnect for alternative network providers?*

Question 31. *Might this be mitigated, by for example continued provision of interconnect at some existing sites?*

Question 32. *Where the impact cannot be mitigated, what principles should determine whether BT should pay compensation, and, if so, to what level?*

Transition process

4.12 Alternative providers have made significant investments based on existing regulated access products and their future investments will depend on expectations about future

regulated access products. Recognising that these products are likely to evolve and that the transition process may be complex, Ofcom believes it is important that this process is very carefully and transparently project managed. In particular, we believe it is important that:

- Alternative providers are alerted as soon as possible where there is potential for change to regulated products (ie before any decision is made) and that plans for proposed changes are communicated at an early stage
 - BT and its wholesale customers work together to manage the detailed technical, process and commercial issues arising from transition. Addressing these issues will almost certainly require the establishment of new cross-industry working groups and processes.
 - A transition plan for regulated products is agreed so that all providers have visibility of changes and can make business decisions based on predictable timings.
 - Formal notice is given to alternative providers with a lead time that is commensurate with the scale and impact of the change. BT already has a requirement to notify technical information in several markets, although a substantially longer notice period than the minimum of 90 days is likely to be appropriate where major changes are planned.
 - Where retail services are based on current regulated wholesale products, those retail services are not disrupted because of changes in the underlying network inputs.
- 4.13 Particular attention needs to be paid to minimising 'transitional bottlenecks'. These are competition problems that arise during the migration process, but do not apply in a steady state situation either to traditional PSTN networks or NGNs. A good example is the end-to-end delay that might arise for narrowband voice services when calls pass between a series of legacy networks and NGNs via TDM gateways (see Section 5 for more detail).

Section 5

Service specific issues

- 5.1 Section 2 discussed the general application of Ofcom's regulatory principles, with particular reference to those forms of access and interconnection that are generic, in the sense that they are capable of supporting a wide range of retail services. Physical unbundling and bitstream interconnection are the two most important examples of generic access and interconnection remedies.
- 5.2 Several service-specific interconnection remedies have also been imposed on BT. This is because BT has historically used different networks to deliver different retail services. In order to provide wholesale equivalents of these different retail services, it has been necessary to interconnect in an appropriate manner with these different networks, for example:
- BT has historically delivered voice services, and dial-up internet access, using its PSTN network. Other operators can interconnect with this PSTN network and purchase a variety of wholesale interconnection services from BT (call origination, transit, and termination).
 - BT has historically delivered leased line services using its PDH/SDH network. Other operators can interconnect with BT's SDH network and purchase wholesale Partial Private Circuits.
 - BT delivers broadband services using a combination of ATM and IP. Other operators can interconnect with BT's broadband network, either at the ATM or the IP layer, and purchase wholesale broadband origination and conveyance services (DataStream and IPStream respectively).
- 5.3 BT also provides several service-specific wholesale access services. These include narrowband exchange lines (Wholesale Line Rental) and broadband access (DataStream End User Access).
- 5.4 This section considers whether these service-specific access and interconnection remedies are still likely to be required, given the convergence associated with 21CN, and if so, how these remedies may need to evolve.

Voice services

- 5.5 We identify four different categories of voice services, each of which makes different demands on the underlying network, and each of which raises different regulatory issues. The four categories are:
- PSTN voice. We include in this category all those narrowband voice services delivered over the traditional PSTN network
 - Basic derived voice. We include in this category those 'Voice over Broadband' services which are delivered over an IP network, and where the service provider requires access only to functionality provided at the IP layer. This includes voice services provided by ISPs, as well as peer-to-peer services such as Skype.
 - Enhanced derived voice. We include in this category those voice services that are delivered over an IP network, but where some form of additional value is provided at the application layer. This additional value may require access to additional network functionality (e.g. location aware services). Such services are likely to

become increasingly important in the future, as network operators seek to retain control of voice revenues.

- Business voice services. We included in this category those enhanced voice services targeted at the business market. Typical characteristics are an enhanced feature set, and support for multiple sites. Examples include VPN services such as FeatureNet.

PSTN voice

5.6 Many of the access and interconnection remedies currently imposed on BT relate to PSTN voice services (IA/CPS/NTS call origination, transit services, call termination). A number of issues relevant to these services are discussed below:

- Evolution of voice remedies
- Potential for withdrawal of voice specific regulation
- Network rearrangement and DLE withdrawal
- Technical standards for signalling
- Transport interfaces and end-to-end delay

Evolution of voice remedies

5.7 As 21CN is introduced existing voice specific remedies, including CPS and WLR will continue to be supported. Notwithstanding the issues identified below, existing providers should be able to continue to use these in the same way as today. However, the introduction of a new IP based network provides the opportunity for new versions of these services to be developed and these may have new service characteristics. Possible changes include:

- A move towards a flat rate charge for call origination and termination, included within the fixed access charge
- Technical convergence of narrowband and broadband access services

Flat rate charging.

5.8 Origination and termination of voice calls has historically been charged for on a pence per minute basis (usage-based charging), whereas IP services are often, but not exclusively, capacity based. In the case of BT's legacy PSTN network, origination and termination charges are required to pay for transmission between the remote concentrator and the local exchange, and switching at the local exchange. However, 21CN will no longer include these network elements. It is likely that MSAN costs will be driven primarily by the number of lines, rather than by usage, in which case a pence per minute charge for origination and termination at the MSAN might no longer be required. Future charging arrangements for voice services might therefore include:

- A line rental product that includes IP origination and termination at the MSAN within a fixed subscription charge.
- A capacity based (based on Megabits per second) or usage based (based on Gigabytes transferred) product for conveyance of IP traffic from the MSAN to the metro node.

Question 33. *Would it still be relevant for future IP based versions of voice interconnect services to be charged on a pence per minute basis or should other charging schemes (e.g. flat-rate origination and termination included within the line rental) be considered?*

Converged access.

- 5.9 At present narrowband access and broadband access are provided over the same copper loop, but use different transmission equipment (remote concentrators in the case of narrowband, DSL access multiplexers in the case of broadband). However, 21CN will result in narrowband and broadband access being supported using almost identical platforms (combi cards in an MSAN). It will be necessary to consider whether separate narrowband and broadband access remedies (WLR and DataStream End User Access) continue to make sense in the world of 21CN. A possible alternative might be a single wholesale access transport service supporting narrowband and broadband. An alternative provider purchasing this service would take over the line and associated line card in the MSAN, as is currently the case for WLR, and would then have the option of using the combi line card in either narrowband or broadband mode.

Question 34. *Given that 21CN will result in narrowband and broadband access being supported using almost identical platforms, is it sensible to continue to make a distinction between wholesale narrowband access (WLR) and wholesale broadband access (Broadband EUA), or should consideration be given to a single wholesale access transport service supporting narrowband and broadband?*

Potential for withdrawal of voice-specific regulation

- 5.10 Section 8 and Annex H of the Telecoms Review consider possible options for the withdrawal of voice specific regulation. In the context of the move to 21CN a particularly important question is whether take-up of derived voice services ('Voice over Broadband') will eventually allow voice-specific regulation to be withdrawn. Ofcom's current view is that whilst this is an important long term trend, it is likely to be a number of years before take-up of broadband is sufficient to support widespread voice competition based on 'Voice over Broadband'. There will therefore be an ongoing need for some form of voice-specific regulation.
- 5.11 It is possible that Voice over Broadband will have an earlier impact on competition in relation to higher-spending customer deciles, where take-up of broadband is likely to be greatest. This is also the part of the market where competition based on IA/CPS is most effective. As take-up of broadband increases, it may therefore be appropriate to refocus voice-specific regulation on lower-spending customer deciles. This might involve changes to the current IA/CPS interconnection remedies, their replacement by a wholesale end-to-end calls service, or retail regulation targeted at light users. There is however a danger in this approach, in that it is difficult to distinguish between those users who are genuinely light users, and those who have switched their calls to a mobile network operator.

Question 35. *Is it likely that take-up of 'Voice over Broadband' will eventually allow the withdrawal of voice-specific regulation, and if so, under what conditions and over what timescale might this occur?*

Question 36. *Would it be appropriate to consider refocusing voice specific regulation on those low-spending customer deciles least likely to take 'Voice over Broadband' service, and if so, how and when might this be done?*

5.12 In practice Ofcom understands that BT will continue to support PSTN interconnection with its 21CN, via a set of TDM gateways. It is unlikely however that the PSTN replacement service provided by 21CN will support all the legacy features supported by the current PSTN network. It may be appropriate to consider the withdrawal of some legacy features of the PSTN service (e.g. meter pulse, analogue DDI), in which case it will also be necessary to consider the timescale and process for this withdrawal.

Question 37. *Which legacy regulated voice services and line features provided by the current PSTN might not be supported by the 21CN PSTN replacement service, what should be the process for producing a definitive list, and what should be the process and timescale for withdrawing services on this list?*

Network rearrangement and DLE withdrawal

5.13 The network architecture currently proposed by BT raises a number of practical issues. The first important point is that the TDM gateways may be at different locations to the current points of PSTN interconnection. Alternative operators are currently able to interconnect with BT's PSTN network at its tandem exchanges (~76 locations), wide area tandem exchanges (~20 locations) or its local exchanges (~720 exchanges). However, the TDM gateways which will support PSTN interconnection with 21CN may not be co-located with existing PSTN points of interconnection. Interconnecting operators could therefore face significant rearrangement costs, and as discussed in section 4, it would be appropriate for BT to take into account the costs it imposes on others through this rearrangement.

5.14 The withdrawal of PSTN interconnection at BT's local exchanges raises more fundamental issues:

- Call origination and backhaul conveyance (formally referred to as local-tandem conveyance) are currently distinct services, falling within distinct economic markets for the purpose of ex ante regulation. This is because it is possible, at least in principle, for alternative operators to purchase call origination from BT, and either self-provide backhaul, or purchase backhaul from another operator. However, if DLE interconnection is withdrawn, this will result in these services being bundled together. This is likely to make it more difficult to deregulate backhaul services.
- Ofcom recently required BT to make available an end-to-end calls service for those calls that originate and terminate on the same or adjacent local exchange. This was necessary in order to ensure that alternative operators faced the same underlying cost base as BT. The reason that such a service was not required for all call types is that alternative operators are able to obtain the same cost base as BT by interconnecting with BT's local exchanges (see Figure 3 of Ofcom's consultation on CPS local calls⁶). However, if interconnection at BT's local exchanges is withdrawn, then alternative operators will face a cost disadvantage for most local and national calls.

5.15 Section 4 suggested general ways of mitigating for these changes. In the context of voice interconnection it is worth considering whether it is possible either to increase the number of TDM gateways, to cover at least some of the local exchange sites. Alternatively, it might be possible to deliver the same outcome via an appropriate charging structure, under which those operators capable of providing backhaul for

⁶ See "Addressing the local call disadvantage"
http://www.ofcom.org.uk/consultations/past/cps_option/cps_local/

themselves would not be charged if they were forced by the new interconnection arrangements to use BT backhaul.

Question 38. *What compensation arrangements should be considered when alternative operators are forced by BT to re-arrange their PSTN points of interconnection?*

Question 39. *Might it be possible to mitigate the impact of the withdrawal of local exchange interconnection, either by providing TDM gateways at more locations, or by establishing a charging structure under which those operators capable of providing backhaul for themselves would not be charged if they were forced by the new interconnection arrangements to use BT backhaul?*

Technical issues – Signalling

5.16 In addition to considering where operators can interconnect with 21CN, it will be necessary to consider how. There are two aspects to this, transport interfaces and signalling interfaces, and we consider the issue of signalling interfaces first.

5.17 PSTN interconnection is currently based on SS7 signalling, with two variants currently in use in the UK (IUP and ISUP). However, 21CN will use a combination of H248 (between MSANs and call servers within the same network) and SIP (between call servers in different networks). This raises several questions:

- What is the detailed specification for the SIP-based signalling used between networks, and will this support the same range of functionality as the H248 signalling used within networks?
- Is it possible and appropriate for interconnecting operators to communicate directly with BT's MSANs using H248?
- Will only SIP be supported between networks, or will it also be possible to interconnect with 21CN using traditional SS7 signalling?
- Is there a need to support legacy IUP signalling as well as ISUP?
- Will there continue to be differences between the UK feature set and the global feature set?

Question 40. *What issues need to be considered relating to signalling used for PSTN interconnection with 21CN? (for example the SIP specification to be adopted, the availability of SS7 as well as SIP interconnection, the availability of IUP as well as ISUP, the availability to interconnecting operators of H248, support for a UK specific feature set)*

Technical issues – Transport

5.18 Transport-level interconnection of PSTN networks has traditionally been at the 2MBit/s (E1) level, with some migration to 155 MBit/s (STM1) more recently. High capacity interconnects tend to be more efficient, since they use fewer ports, but they may not be supported by older switches. It will be necessary to consider what physical interfaces are supported by the 21CN TDM gateways.

Question 41. *What transmission interfaces need to be considered for TDM gateways used for PSTN interconnection?*

5.19 A particular concern in relation to the use of TDM gateways is that they degrade performance, by introducing delay. This means that an off-net call will be of poorer quality than an on-net call. If this degradation is material, then this will be a competition concern, since it will be difficult for alternative operators to compete with call carried end-to-end over BT's network. Work by the NICC End-to-End QoS Task Group has suggested that the degradation will not be material if a call traverses a single TDM gateway, but that the degradation could be material if a call traverses multiple networks. This is most likely to occur for calls to ported numbers, due to the technical solution ('onward routing') used for number portability in the UK. Further analysis is likely to be required of this issue. The problem might be reduced if the general move to next generation networks results in a new approach to number portability (for example all call query rather than onward routing⁷).

Question 42. *For call types that traverse multiple TDM gateways what is the likely impact on end-to-end QoS, and what options should be considered for mitigating this impact (a new approach to number portability, for example)?*

Question 43. *What other technical issues need to be considered in relation to PSTN interconnection with 21CN?*

Derived voice

5.20 Derived voice services, which include 'Voice over Broadband' services, do not depend on voice specific interconnection with BT in order to originate voice calls. They do however depend on there being an underlying IP transmission path that provides adequate end-to-end quality of service.

5.21 At present, most Voice over Broadband services are provided on a 'best-efforts' basis, with no specific guarantees as to quality of service. This tends to restrict the practical availability of these services to those consumers who either have a high bandwidth broadband connection, or are insensitive to quality of service. If derived voice services are to be used more widely, then it must be possible to deliver them in an efficient manner, over an entry-level broadband connection, and still compete in quality with a traditional PSTN service. This may require the development of a broadband access service and associated interconnect product that permits QoS to be managed on an end-to-end basis.

Question 44. *Would broadband access and interconnection need to evolve to allow derived voice services to be provided in an efficient manner over an entry-level broadband connection, and still provide similar quality of service to PSTN voice?*

5.22 Enhanced derived voice services may raise additional issues. These services will provide additional value at the application layer, exploiting the network intelligence inherent to an NGN. Section 3 considered the issues associated with access to intelligence capabilities.

Question 45. *What other issues need to be considered in relation to derived voice services?*

⁷ See "An assessment of alternative solutions for UK number portability"
http://www.ofcom.org.uk/consultations/past/uk_numb_port/uk_numb_port_cons/

Business voice

- 5.23 The issues discussed above apply to both residential and business voice services. There are however some issues specific to business voice services. Two particularly important issues relate to the evolution of business ISDN services, and voice VPN services such as FeatureNet.
- 5.24 ISDN services have had limited take-up in the residential market, and what take-up there has been is likely to be eroded by the growth over the next few years of broadband services. However, ISDN services are widely used in the business market, often in conjunction with digital PBXs. The large installed base of digital PBXs means that it might be necessary to support business ISDN services for a number of years to come, and this raises a number of service-specific issues. For example, is ongoing support required for ISDN2 as well as ISDN2e, and for all three variants of ISDN30?

Question 46. *What range of regulated business ISDN services is there a need for 21CN to support?*

Question 47. *What scope is there for withdrawal of some legacy regulated ISDN services?*

- 5.25 BT currently provides Voice VPN and Centrex services to the business market using FeatureNet and FeatureLine. These services are not however subject to service specific regulation, on the basis that the underlying access bottleneck is addressed by the availability of wholesale leased lines (PPCs), and that this allows alternative providers to offer their own Voice VPN services. We assume that the same will be true of the Voice VPN services expected to be provided over 21CN. The issue of whether PPCs will continue to be an effective means of addressing the underlying access bottleneck is addressed below.

Question 48. *Do next generation Voice VPNs raise any service-specific requirements in relation to 21CN?*

- 5.26 It is however worth noting that the migration of VPN services tends to raise particularly complex issues, due to the number of sites that must be migrated in a coordinated manner. It is possible that new industry-wide processes will need to be developed to facilitate the migration of current generation voice VPNs to their next generation equivalent.

Question 49. *What options should be considered for managing the migration of current generation Voice VPNs to next generation Voice VPNs and IP VPNs?*

Question 50. *What other issues need to be considered in relation to next generation business voice services?*

Consumer data services: narrowband

- 5.27 21CN is likely to accelerate the migration from dial-up internet access to broadband. In the long run it is unlikely to be efficient to provide an IP service using voice-band modems, when the voice-band signal is in turn being carried over an IP network.
- 5.28 We assume that flat rate dial-up services are likely to be superseded first, since they are already similar in price to entry-level broadband services. Indeed it may ultimately be less costly to provide an entry-level broadband service than a narrowband unmetered one. BT has stated that by summer 2005 99.6% of UK homes and businesses will be connected to a broadband enabled exchange. Once broadband is available to most UK consumers, it might be appropriate to agree a process and timetable for the future withdrawal of FRIACO⁸.
- 5.29 However, it is likely that some consumers will still be unable to obtain broadband, typically because although their exchange is DSL-enabled, they are too far from the exchange to receive a broadband service. Depending on the number of customers in this position, it may be necessary to provide some form of targeted flat-rate service.
- 5.30 Metered dial-up services are likely to persist for longer, since they cater for those consumers who only occasionally access the internet and/or prefer pay as you go charging, and therefore do not have a strong incentive to migrate to broadband. However, it may make sense to handover traffic to terminating operators and ISPs as native IP, rather than as IP over voice over IP. In the longer term, these consumers might ultimately also be catered for by a cut-down (eg low cost, low speed, possibly pay as you go) 'broadband' service.

Question 51. *Once broadband is available to most UK consumers would it be appropriate to agree a process and timetable for the withdrawal of FRIACO?*

Question 52. *If FRIACO is withdrawn, over what timescale should this take place in order to allow an orderly migration, and what process issues need to be considered?*

Question 53. *Is there likely to be a long-term need for some form of flat-rate dial-up internet access service, to cater for those consumers unable to receive broadband services?*

Question 54. *What form of entry-level internet access service would be appropriate for those consumers who only occasionally access the internet, and who therefore do not have a strong incentive to migrate to broadband?*

Question 55. *What other issues need to be considered in relation to consumer narrowband data services?*

Consumer data services: broadband and multimedia

- 5.31 It is currently possible to provide consumer broadband services based on three different wholesale services from BT – LLU, DataStream and IPStream. These are all generic access and interconnection services, in that they are capable of supporting a

⁸ Note that by raising this question, Ofcom is not in anyway prejudicing current work on the FRIACO adjustment ratio

wide range of downstream services, not just consumer broadband. Current consumer broadband services place no specific demands on these services, and so there currently appears to be no requirement for a regulated access or interconnection service specific to consumer broadband.

- 5.32 This may however change in the future, if the range of consumer broadband services increases to include multimedia services such as real time video. If this were to happen, it might be desirable to have an interconnection service that permits QoS to be managed on an end-to-end basis. If this were not possible, then it may be necessary to consider a specific form of access for such services.

Question 56. *Is it likely that consumer broadband services will in the future require some form of managed QoS, or some other specialised capability, due to the introduction of new multimedia services such as real-time video?*

Question 57. *If so, might this be best delivered through changes to the underlying generic access and interconnection services, or would there be a need for new forms of access and interconnection specifically designed to support such requirements as real-time video?*

- 5.33 BT currently makes available two forms of interconnection with its broadband network, at the ATM layer (DataStream) and at the IP layer (IPStream). These are however likely to be affected by two key technology trends:

- We expect that the QoS management capability currently provided by ATM will in the future also be available at the IP layer, based on the use of MPLS; and
- We expect that ATM will gradually be displaced as a means of providing backhaul by Gigabit Ethernet.

- 5.34 Given these trends, it may be possible to replace the two existing forms of broadband interconnection by a single IP interconnection service. This would have to support a range of options for managing QoS, including a basic 'best-efforts' service, comparable to the current IPStream service, plus an enhanced MPLS-based managed-QoS service.

Question 58. *Is it reasonable to consider replacing the two existing forms of broadband interconnection (IPStream and DataStream) with a single converged IP interconnection service, incorporating the option of MPLS-based QoS management, in addition to a basic 'best-efforts' service?*

Question 59. *If some form of layer 2 (e.g. ATM or Ethernet) broadband interconnection continues to be required, as well as IP interconnection, how is this likely to be affected by the migration from ATM to Gigabit Ethernet?*

Question 60. *What other issues need to be considered in relation to consumer broadband data services?*

Business data services

- 5.35 The range of data services provided to the business market is very broad, much more so than the range of data services currently provided to the residential market. A

particularly important difference between business data services and consumer data services is that business services tend to require some form of QoS guarantee. This can be delivered by providing dedicated transmission capacity, as in the case of leased lines. Alternatively, it can be delivered through the provision of virtual capacity over a shared network, but with managed QoS, using technologies such as Frame Relay, ATM or MPLS.

- 5.36 Business data services are not currently subject to an extensive range of service specific regulation, on the basis that the underlying access bottleneck is addressed by the availability of wholesale leased lines (PPCs), and more recently by a wholesale bitstream service with managed QoS (DataStream). There are several ways in which these services might evolve in light of 21CN.
- 5.37 Traditional leased line services have been based on PDH and SDH technology. One question that arises is how these legacy services will be provided over 21CN. Some SDH services might continue to be provided directly over BT's optical transmission network. However, it might be more cost-effective to provide some other services using circuit-emulation technology, and carrying the service over 21CN using ATM or IP/MPLS. In this case issues might arise as to the technical standards adopted, and the basis on which these services are charged.

Question 61. *Which legacy leased line services are likely to continue to be provided directly over optical transmission network, and which might be provided using circuit emulation technology over NGNs?*

Question 62. *What technical and commercial issues might be raised if BT were to use circuit emulation technology to provide leased line services over 21CN?*

- 5.38 It is in any case unlikely that it will be cost-effective to support the full range of legacy leased line services indefinitely. Several legacy services are already withdrawn from new supply, including certain variants of analogue private circuits and KiloStream, as well as 8MBit/s Megastream services. The question that arises is whether existing circuits of these types will be supported by 21CN, and whether any further legacy leased line services will be withdrawn.

Question 63. *Which legacy leased line services are likely to no longer be needed over 21CN?*

- 5.39 A shift is underway from SDH to newer transmission technologies, notably Gigabit Ethernet. This has been particularly pronounced in relation to business data services, but may in the future also be relevant to voice services. This suggests that a next generation leased line service provided over 21CN might be predominantly based on Ethernet rather than SDH, and this in turn raises a number of product design issues, for example:
- The PPC model for a wholesale leased line is based on a number of 'partial circuits' serving individual business sites, all feeding into a single 'fat-pipe' SDH interconnect. However, Ethernet services tend to be provided on a point-to-point basis, and therefore do not lend themselves readily to this PPC model.
 - Although the basic Ethernet standard is well specified, a number of variants are currently under development. These include variants designed to deliver greater

resilience ('Resilient packet rings'), higher bandwidth ('10 Gigabit Ethernet') and longer reach ('Ethernet in the first mile'). There is a question as to which of these innovative standards might be supported by an Ethernet-based wholesale leased line service.

Question 64. *Would it be appropriate for next generation leased line service provided over 21CN to focus on new transmission technologies such as Gigabit Ethernet?*

Question 65. *What would be the desirable characteristics of an Ethernet based wholesale leased line, and which variants of the Ethernet technical standards should be considered (100Mbps Fast Ethernet, Gigabit, 10 Gigabit, Long Reach Ethernet, Resilient Packet Ring, etc)?*

Question 66. *Are there certain types of business services that will continue to need PDH/SDH-based transmission, or will PDH and SDH increasingly become legacy services?*

5.40 A more focussed alternative to existing partial private circuit (PPC) regulation could be to address the underlying economic bottleneck for businesses services directly, and do so at the deepest possible service level, deregulating elsewhere. One means of doing so might be for BT to provide selective access to dark fibre in those geographies where it has significant market power (SMP). This might reduce the need for the more widespread regulation of downstream products such as PPCs. It might also be a better means of supporting innovation, removing the need (for example) to specify in advance which variants of Ethernet should be supported. There is an obvious analogy between this approach to dark fibre access and the provision of access to 'dark copper' via local loop unbundling.

Question 67. *Might selective access to dark fibre, in those geographies where there is no alternative supply, be a more targeted means of addressing the underlying access bottleneck than a general requirement to provide wholesale leased lines?*

Question 68. *Might access to dark fibre be more likely to result in significant service innovation, because of the ability to deploy new transmission technologies (e.g. new variants of Ethernet)?*

5.41 The other alternative to wholesale leased lines would be the provision of some form of bitstream interconnection, but with managed QoS, similar to the current DataStream service. This might be based on ATM, as with the current DataStream service, but it is more likely to be based on IP/MPLS.

Question 69. *Might some form of QoS-enabled bitstream interconnection, similar to the current DataStream service, be an effective means of enabling competition in the market for business data services?*

Question 70. *If so, would ATM or IP/MPLS be appropriate, and what technical issues would need to be resolved in order for the service to be effective?*

5.42 This section has described three different means of addressing the access bottleneck associated with the business market – next generation leased lines, a QoS-enabled

bitstream service, or access to dark fibre. Ofcom is however keen to focus regulation on a limited number of access and interconnection remedies, and would welcome feedback as to which of these three options should be its primary focus.

Question 71. *If Ofcom was to focus regulation on just one of the three different means of addressing the access bottleneck associated with the business market (dark fibre, leased lines, QoS-enabled bitstream), which would you choose?*

Question 72. *What other issues need to be considered in relation to business data services?*

Section 6

Summary and way forward

Summary of issues identified

Access / service type	Summary of main issues / questions
Generic access/interconnect	
All forms of interconnect	Arrangements for closure of existing points of interconnect and migration to new metro node sites
LLU	Impact of Broadband dial tone on LLU providers and how LLU processes may need to evolve.
MSAN access	Desirability and form (eg bitstream v voice specific) of access at the MSAN
Metro node access	Focus of regulation on first metro node rather than on inter-metro conveyance, geographic rearrangement of nodes
Intelligence capabilities	Identification of intelligence capabilities and the appropriate form of access to these
Service specific access/interconnect	
PSTN Voice	<ul style="list-style-type: none"> - Possible move from pence per minute to flat rate origination and termination - Convergence of WLR and wholesale broadband access onto single access product - Impact of voice over broadband on competition in PSTN voice - Support for and withdrawal of legacy voice features - Impact of DLE withdrawal and means of mitigating - Technical standards for PSTN interconnection - Impact of multiple media gateways on end to end delay
Derived voice (Voice over Broadband)	<ul style="list-style-type: none"> -Dependency on QoS and reliability of broadband access network -Need for access to intelligence capabilities for enhanced derived voice
Business voice	<ul style="list-style-type: none"> - Need for support of all ISDN variants on 21CN - Migration of current generation Voice VPNs to next generation Voice VPNs and IP VPNs
Consumer data services (narrowband)	<ul style="list-style-type: none"> - Long term future of FRIACO - Future entry-level internet access product
Consumer data services (broadband)	<ul style="list-style-type: none"> - Need for managed QoS for broadband and multimedia services - Future of IPStream and Datastream
Business data services (leased lines)	<ul style="list-style-type: none"> - Provision of legacy leased line products through circuit emulation - Withdrawal of legacy leased line products - Future business data access products – Ethernet v QoS enabled bitstream v dark fibre

- 6.1 A wide range of access and interconnect products have been discussed in this document. The table below provides a summary of the main issues identified for each one.

Way forward

- 6.2 This document has illustrated that there is clearly a substantial task ahead to resolve the access and interconnect issues raised by 21CN. We believe the key elements of the way forward are:
- Effective industry engagement
 - Technical interoperability and standardisation.
 - This consultation process, together with regular dialogue between Ofcom and stakeholders.

Effective industry engagement

- 6.3 The most significant element to taking forward the issues identified is likely to be through effective dialogue between BT and other providers. However, for such a negotiation process to be effective, it will be necessary both for BT to engage in an open and transparent manner and for alternative providers to commit significant resource, commercial and technical, to the development of possible solutions.
- 6.4 All parties have recognised the importance of this dialogue and BT has committed to a consultation process with industry. Over the last couple of months some progress has been made, for example dialogue has started between BT and other providers on MSAN interconnection. Ofcom wants these discussions to succeed because the issues are better taken forward through constructive industry negotiation rather than regulatory intervention. However, Ofcom's perception is that the process has not been perfect and that experience suggests potential risks for the future. To help this process succeed it is worth considering what those risks are.
- 6.5 Firstly, there is a risk that discussions remain at a very high level. Given the detailed and complex nature of many of the questions raised we think it is important that BT and alternative providers are able to discuss these matters in greater depth than they have to date. This will require openness on both sides, to discuss options and share information whilst these are still tentative.
- 6.6 Secondly, for negotiations to progress both parties need to have the resources and capability to deliver as well as the intention. A recent specific example is that the provision of information on interconnect locations has been delayed longer than expected. Another obvious but practical concern would be if key personnel are overloaded so that simply trying to arrange a time for a meeting created a barrier to progress.

Technical interoperability

- 6.7 Ofcom also recognises that many of the issues raised by 21CN are technical in nature; for example new interconnect products may depend on the development of appropriate technical standards. In the past these would have been expected to have been addressed by the UK Network Interoperability Consultative Committee (NICC). However, the level of challenge created by 21CN is likely to require some restructuring of NICC, in order to provide adequate focus on 21CN issues, and is likely to require a significantly increased level of resource commitment from industry.

- 6.8 One means of improving the level of engagement between operators and NICC might be for Chief Technology Officers of the major operators to attend NICC board meetings. Ofcom encourages the exploration of this and other options for ensuring that the technical issues raised by 21CN are addressed in a timely manner.

Consultation next steps

- 6.9 Ofcom is committed to helping the industry meet the ambitious timetable set out for the implementation of next generation networks. Given the importance and pressing nature of many of the issues raised, this consultation has a 5 week consultation period (excluding a 2 week period covering Christmas and the new year), closing on 13th January 2005. Ofcom expects to publish a statement in early 2005 summarising the responses, and considering how to take the various issues

Section 7

Responding to this consultation

- 7.1 Ofcom invites written views and comments on the issues raised in this document, to be made by **5pm on Thursday 13th January 2005**.
- 7.2 Ofcom strongly prefers to receive responses as e-mail attachments, in Microsoft Word format, as this helps us to process the responses quickly and efficiently. We would also be grateful if you could assist us by completing a response cover sheet (see Annex B), among other things to indicate whether or not there are confidentiality issues. The cover sheet can be downloaded from the 'Consultations' section of our website.
- 7.3 Please can you send your response to first justin.moore@ofcom.org.uk
- 7.4 Responses may alternatively be posted or faxed to the address below, marked with the title of the consultation.

Justin Moore
 Competition and Market
 4th floor
 Ofcom
 Riverside House
 2A Southwark Bridge Road
 London SE1 9HA

Fax: 020 7981 3333

- 7.5 Note that we do not need a hard copy in addition to an electronic version. Also note that Ofcom will not routinely acknowledge receipt of responses.
- 7.6 It would be helpful if your response could include direct answers to the questions asked in this document, which are listed together at Annex C. It would also help if you can explain why you hold your views, and how Ofcom's proposals would impact on you.

Further information

- 7.7 If you have any want to discuss the issues and questions raised in this consultation, or need advice on the appropriate form of response, please contact Justin Moore on 020 7783 4167.

Confidentiality

- 7.8 Ofcom thinks it is important for everyone interested in an issue to see the views expressed by consultation respondents. We will therefore usually publish all responses on our website, www.ofcom.org.uk. We will do this on receipt of responses, unless respondents request otherwise on their response cover sheet.
- 7.9 All comments will be treated as non-confidential unless respondents specify that part or all of the response is confidential and should not be disclosed. Please place any confidential parts of a response in a separate annex, so that non-confidential parts may be published along with the respondent's identity.

- 7.10 Ofcom reserves its power to disclose any information it receives where this is required to carry out its functions. Ofcom will exercise due regard to the confidentiality of information supplied.
- 7.11 Please also note that copyright and all other intellectual property in responses will be assumed to be licensed to Ofcom to use, to meet its legal requirements. Ofcom's approach on intellectual property rights is explained further on its website, at www.ofcom.org.uk/about_ofcom/gov_accountability/disclaimer.

Next steps

- 7.12 Following the end of the consultation period, Ofcom intends to publish a statement early in 2005.
- 7.13 Please note that you can register to get automatic notifications of when Ofcom documents are published, at http://www.ofcom.org.uk/static/subscribe/select_list.htm

Ofcom's consultation processes

- 7.14 Ofcom is keen to make responding to consultations easy, and has published some consultation principles (see Annex A) which it seeks to follow, including on the length of consultations.
- 7.15 This consultation is shorter than Ofcom's standard 10 week period for the reasons set out in Section 2.
- 7.16 If you have any comments or suggestions on how Ofcom conducts its consultations, please call our consultation helpdesk on 020 7981 3003 or e-mail us at consult@ofcom.org.uk. We would particularly welcome thoughts on how Ofcom could more effectively seek the views of those groups or individuals, such as small businesses or particular types of residential consumers, whose views are less likely to be obtained in a formal consultation.
- 7.17 If you would like to discuss these issues, or Ofcom's consultation processes more generally, you can alternatively contact Philip Rutnam, Partner, Competition and Strategic Resources, who is Ofcom's consultation champion:

Philip Rutnam
Ofcom
Riverside House
2A Southwark Bridge Road
London SE1 9HA
Tel: 020 7981 3585
Fax: 020 7981 3333
E-mail: philip.rutnam@ofcom.org.uk

Annex A

Ofcom's consultation principles

A2.1 Ofcom has published the following seven principles that it will follow for each public written consultation:

Before the consultation

A2.2 Where possible, we will hold informal talks with people and organisations before announcing a big consultation to find out whether we are thinking in the right direction. If we do not have enough time to do this, we will hold an open meeting to explain our proposals shortly after announcing the consultation.

During the consultation

A2.3 We will be clear about who we are consulting, why, on what questions and for how long.

A2.4 We will make the consultation document as short and simple as possible with a summary of no more than two pages. We will try to make it as easy as possible to give us a written response. If the consultation is complicated, we may provide a shortened version for smaller organisations or individuals who would otherwise not be able to spare the time to share their views.

A2.5 We will normally allow ten weeks for responses, other than on dispute resolution.

A2.6 There will be a person within Ofcom who will be in charge of making sure we follow our own guidelines and reach out to the largest number of people and organisations interested in the outcome of our decisions. This individual (who we call the consultation champion) will also be the main person to contact with views on the way we run our consultations.

A2.7 If we are not able to follow one of these principles, we will explain why. This may be because a particular issue is urgent. If we need to reduce the amount of time we have set aside for a consultation, we will let those concerned know beforehand that this is a 'red flag consultation' which needs their urgent attention.

After the consultation

A2.8 We will look at each response carefully and with an open mind. We will give reasons for our decisions and will give an account of how the views of those concerned helped shape those decisions.

Annex B

Consultation response cover sheet

- B.1 In the interests of transparency, we will publish all consultation responses in full on our website, www.ofcom.org.uk, unless a respondent specifies that all or part of their response is confidential. We will also refer to the contents of a response when explaining our decision, unless we are asked not to.
- B.2 We have produced a cover sheet for responses (see below) and would be very grateful if you could send one with your response. This will speed up our processing of responses, and help to maintain confidentiality by allowing you to state very clearly what you don't want to be published. We will keep your completed cover sheets confidential.
- B.3 The quality of consultation can be enhanced by publishing responses before the consultation period closes. In particular, this can help those individuals and organisations with limited resources or familiarity with the issues to respond in a more informed way. Therefore Ofcom would encourage respondents to confirm on the response cover sheet that Ofcom can publish their responses upon receipt.
- B.4 We strongly prefer to receive responses in the form of a Microsoft Word attachment to an email. Our website therefore includes an electronic copy of this cover sheet, which you can download from the 'Consultations' section of our website.

Please put any confidential parts of your response in a separate annex to your response, so that they are clearly identified. This can include information such as your personal background and experience. If you want your name, contact details, or job title to remain confidential, please provide them in your cover sheet only so that we don't have to edit your response.

Cover sheet for response to an Ofcom consultation

BASIC DETAILS

Consultation title: Next Generation Networks

To (Ofcom contact):

Name of respondent:

Representing (self or organisation/s):

Address (if not received by email):

CONFIDENTIALITY

What do you want Ofcom to keep confidential?

Nothing	<input type="checkbox"/>	Name/contact details/job title	<input type="checkbox"/>
Whole response	<input type="checkbox"/>	Organisation	<input type="checkbox"/>
Part of the response	<input type="checkbox"/>	If there is no separate annex, which parts?	

If you want part of your response, your name or your organisation to be confidential, can Ofcom still publish a reference to the contents of your response (including, for any confidential parts, a general summary that does not disclose the specific information or enable you to be identified)?

DECLARATION

I confirm that the correspondence supplied with this cover sheet is a formal consultation response. It can be published in full on Ofcom’s website, unless otherwise specified on this cover sheet, and I authorise Ofcom to make use of the information in this response to meet its legal requirements. If I have sent my response by email, Ofcom can disregard any standard e-mail text about not disclosing email contents and attachments.

Ofcom seeks to publish responses on receipt. If your response is non-confidential (in whole or in part), and you would prefer us to publish your response only once the consultation has ended, please tick here.

Name Signed (if hard copy)

Annex C

Consultation questions

Link to Telecoms Review

C.1 Where there is an overlap between the more detailed questions in this consultation and the Telecoms Review, there is no need to answer the related questions in the Telecoms Review as well. Specifically the following question from the Telecoms Review can be omitted: 8c); 10b); 11; 12; 14; 15.

Section 3

Question 1. *What are your views on the potential for competition based on access at different geographic levels (local/metro/core) and the way this may vary depending on geography?*

Question 2. *In what areas might regulatory withdrawal be feasible if 21CN enabled the delivery of improved equivalence, including 'equivalence of inputs'?*

Question 3. *What opportunities are there for generic access products to enable withdrawal of regulation from existing service specific products?*

Question 4. *What approaches should be considered for focusing regulation on enduring economic bottlenecks?*

Question 5. *What principles should Ofcom adopt in order to promote a favourable climate for efficient and timely investment by all operators in Next Generation Networks?*

Question 6. *Do you think there may be demand for products offering access at the MSAN in addition or as an alternative to LLU? Are there relevant issues other than LLU migration processes and enabling backhaul competition?*

Question 7. *What is the potential impact on LLU operators and competition in broadband access of the widespread availability of broadband dial-tone?*

Question 8. *Is it likely to be sufficient for LLU operators to have 'near-equivalence' compared to broadband dial tone, and if so, how short must provisioning timescales be?*

Question 9. *What is the shortest provisioning timescale that might reasonably be delivered by a re-engineered manual migration process for LLU? If a re-engineered manual migration process is likely to be inadequate, then what alternative means should be considered to ensure operators can compete on an equal basis with a broadband dial tone (eg copper cross-connect, 'soft LLU')?*

Question 10. *If some form of 'soft LLU' was made available, might it be practical to provide alternative providers with an ability to configure line cards independently of each other, based on an 'operator profile'?*

Question 11. *To what extent, and over what timescale, might operators realistically build out their own networks to the MDF/MSAN nodes, thereby enabling a competitive market in backhaul services?*

Question 12. *Are there parts of the UK where backhaul between MSAN nodes and Metro nodes should be regarded as an enduring economic bottleneck?*

Question 13. *Might MSAN interconnection enable sustainable competition in backhaul in geographies where LLU is not viable?*

Question 14. *Is it likely to be cost-effective for MSANs to support dynamic routing of IP traffic, and if not, what alternative options should be considered for providing some form of MSAN interconnection?*

Question 15. *If MSAN interconnection were appropriate, what level of access (eg layer 2 v layer 3 v voice interconnect) is likely to be suitable?*

Question 16. *Is it possible to rule out at this stage the option of providing service specific interconnect at every MSAN?*

Question 17. *Given that MPLS technology is only likely to be deployed within core networks, at least for the immediate future, how might services based on some form of MSAN interconnection provide adequate quality of service?*

Question 18. *What are the aspects of equivalence of input that would need to be considered for MSAN interconnection?*

Question 19. *Do you believe that inter metro node conveyance is not an enduring economic bottleneck and therefore, where LLU/MSAN access competition is not viable, that regulation should be focussed on access at the first metro node?*

Question 20. *Is the ability of operators to build out to metro nodes likely to vary geographically, resulting in the need for conveyance to some nodes to be regulated on an ongoing basis?*

Question 21. *What would the characteristics be of a metro node access product supporting equivalence of input?*

Question 22. *Under what circumstances should BT face specific access obligations for intelligence capabilities due to its SMP in a related market and what specific examples are there?*

Question 23. *Under what circumstances should access to intelligence capabilities be regulated on a reciprocal basis and what specific examples are there?*

Question 24. *To what extent might commercially negotiated access to intelligence capabilities remove the need for regulation?*

Question 25. *Is it important to consider the provision of deeper hooks to directly access intelligence capabilities and is this access likely to be practical?*

Question 26. *What might be the benefits from achieving equality of access to 21CN OSS, and do these require adoption of 'equivalence of inputs', or is some form of compromise appropriate?*

Question 27. *What might be the practical barriers to achieving 'equivalence of inputs' in relation to 21CN OSS, and do you believe that these are likely to be surmountable?*

Section 4

Question 28. *What do believe the appropriate guiding principles should be for the transition from existing access and interconnection arrangements to new arrangements? Do you agree with Ofcom's proposed principles?*

Question 29. *What types of product migrations are there likely to be for 21CN and what general issues do they raise?*

Question 30. *What might be the impact of geographic migration of points of interconnect for alternative network providers?*

Question 31. *Might this be mitigated, by for example continued provision of interconnect at some existing sites?*

Question 32. *Where the impact cannot be mitigated, what principles should determine the level of compensation paid by BT?*

Section 5

Question 33. *Would it still be relevant for future IP based versions of voice interconnect services to be charged on a pence per minute basis or should other charging schemes (e.g. flat-rate origination and termination included within the line rental) be considered?*

Question 34. *Given that 21CN will result in narrowband and broadband access being supported using almost identical platforms, is it sensible to continue to make a distinction between wholesale narrowband access (WLR) and wholesale broadband access (Broadband EUA), or should consideration be given to a single wholesale access transport service supporting narrowband and broadband?*

Question 35. *Is it likely that take-up of 'Voice over Broadband' will eventually allow the withdrawal of voice-specific regulation, and if so, under what conditions and over what timescale might this occur?*

Question 36. *Would it be appropriate to consider refocusing voice specific regulation on those low-spending customer deciles least likely to take 'Voice over Broadband' service, and if so, how and when might this be done?*

Question 37. *Which legacy voice services and line features provided by the current PSTN might not be supported by the 21CN PSTN replacement service, what should be the process for producing a definitive list, and what should be the process and timescale for withdrawing services on this list?*

Question 38. *What compensation arrangements should be considered when alternative operators are forced by BT to re-arrange their PSTN points of interconnection?*

Question 39. *Might it be possible to mitigate the impact of the withdrawal of local exchange interconnection, either by providing TDM gateways at more locations, or by establishing a charging structure under which those operators capable of providing backhaul for themselves would not be charged if they were forced by the new interconnection arrangements to use BT backhaul?*

Question 40. *What issues need to be considered relating to signalling used for PSTN interconnection with 21CN? (for example the SIP specification to be adopted, the availability*

of SS7 as well as SIP interconnection, the availability of IUP as well as ISUP, the availability to interconnecting operators of H248, support for a UK specific feature set))

Question 41. *What transmission interfaces need to be considered for TDM gateways used for PSTN interconnection?*

Question 42. *For call types that traverse multiple TDM gateways what is the likely impact on end-to-end QoS, and what options should be considered for mitigating this impact (a new approach to number portability, for example)?*

Question 43. *What other technical issues need to be considered in relation to PSTN interconnection with 21CN?*

Question 44. *Would broadband access and interconnection need to evolve to allow derived voice services to be provided in an efficient manner over an entry-level broadband connection, and still provide similar quality of service to PSTN voice?*

Question 45. *What other issues need to be considered in relation to derived voice services?*

Question 46. *What range of business ISDN services is there a need for 21CN to support?*

Question 47. *What scope is there for withdrawal of some legacy ISDN services?*

Question 48. *Do next generation Voice VPNs raise any service-specific requirements in relation to 21CN?*

Question 49. *What options should be considered for managing the migration of current generation Voice VPNs to next generation Voice VPNs and IP VPNs?*

Question 50. *What other issues need to be considered in relation to next generation business voice services?*

Question 51. *Once broadband is available to most UK consumers would it be appropriate to agree a process and timetable for the withdrawal of FRIACO?*

Question 52. *If FRIACO is withdrawn, over what timescale should this take place in order to allow an orderly migration, and what process issues need to be considered?*

Question 53. *Is there likely to be a long-term need for some form of flat-rate dial-up internet access service, to cater for those consumers unable to receive broadband services?*

Question 54. *What form of entry-level internet access service would be appropriate for those consumers who only occasionally access the internet, and who therefore do not have a strong incentive to migrate to broadband?*

Question 55. *What other issues need to be considered in relation to consumer narrowband data services?*

Question 56. *Is it likely that consumer broadband services will in the future require some form of managed QoS, or some other specialised capability, due to the introduction of new multimedia services such as real-time video?*

Question 57. *If so, might this be best delivered through changes to the underlying generic access and interconnection services associated with 21CN, or by the introduction of new*

forms of access and interconnection specifically designed to support such requirements as real-time video?

Question 58. *Is it reasonable to consider replacing the two existing forms of broadband interconnection (IPStream and DataStream) with a single converged IP interconnection service, incorporating the option of MPLS-based QoS management, in addition to a basic 'best-efforts' service?*

Question 59. *If some form of layer 2 (e.g. ATM or Ethernet) broadband interconnection continues to be required, as well as IP interconnection, how is this likely to be affected by the migration from ATM to Gigabit Ethernet?*

Question 60. *What other issues need to be considered in relation to consumer broadband data services?*

Question 61. *Which legacy leased line services are likely to continue to be provided directly over optical transmission network, and which might be provided using circuit emulation technology over NGNs?*

Question 62. *What technical and commercial issues might be raised if BT were to use circuit emulation technology to provide leased line services over 21CN?*

Question 63. *Which legacy leased line services are likely no longer to be needed over 21CN?*

Question 64. *Would it be appropriate for next generation leased line services provided over 21CN to focus on new transmission technologies such as Gigabit Ethernet?*

Question 65. *What would be the desirable characteristics of an Ethernet based wholesale leased line, and which variants of the Ethernet technical standards should be considered (100Mbps Fast Ethernet, Gigabit, 10 Gigabit, Long Reach Ethernet, Resilient Packet Ring, etc)?*

Question 66. *Are there certain types of business services that will continue to need PDH/SDH-based transmission, or will PDH and SDH increasingly become legacy services?*

Question 67. *Might selective access to dark fibre, in those geographies where there is no alternative supply, be a more targeted means of addressing the underlying access bottleneck than a general requirement to provide wholesale leased lines?*

Question 68. *Might access to dark fibre be more likely to result in significant service innovation, because of the ability to deploy new transmission technologies (e.g. new variants of Ethernet)?*

Question 69. *Might some form of QoS-enabled bitstream interconnection, similar to the current DataStream service, be an effective means of enabling competition in the market for business data services?*

Question 70. *If so, would ATM or IP/MPLS be appropriate, and what technical issues would need to be resolved in order for the service to be effective?*

Question 71. *If Ofcom was to focus regulation on just one of the three different means of addressing the access bottleneck associated with the business market (dark fibre, leased lines, QoS-enabled bitstream), which would you choose?*

Question 72. *What other issues need to be considered in relation to business data services?*

Annex D

Glossary

21st Century Network, or 21CN

BT's 21st Century Network, its planned next generation core network

ADSL Asymmetric Digital Subscriber Line.

A digital technology that allows the use of a copper line to support high bandwidths in one direction and a lesser bandwidth in the other.

Altnet(s)

Alternative fixed network operator.

ATM

Asynchronous Transfer Mode, a standard for high speed data communications.

Bottleneck

The part of a network where the economics of supplying alternative networks are such that effective competition is unlikely to emerge.

Broadband

An service or connection generally defined as being 'always-on', and providing a bandwidth greater than 128kbit/s.

BT

British Telecommunications plc.

Bundling

Linking the purchase of one product or service to another, either by selling only as a package, or through the use of discounts for joint purchasing.

Core network

The centralised part of a network, characterised by a high level of traffic aggregation, high capacity links and a relatively small number of nodes.

CPS

Carrier Pre-selection. The facility offered to customers which allows them to opt for certain defined classes of call to be carried by an operator selected in advance (and having a contract with the customer) without having to dial a routing prefix, use a dialler box, or follow any other different procedure to invoke such routing.

DSL

Digital Subscriber Line. A family of technologies generally referred to as DSL, or xDSL, capable of transforming ordinary phone lines (also known as 'twisted copper pairs') into high-speed digital lines, capable of supporting advanced services such as fast internet access and video-on-demand. ADSL, HDSL (High data rate Digital Subscriber Line) and VDSL (Very high data rate Digital Subscriber Line) are all variants of xDSL.

Equivalence

The principle that BT's wholesale customers should have access to the same or a similar set of mandated wholesale products, at the same prices and using the same or similar transactional processes, as BT's own retail activities.

Ex ante

Before an event takes place.

Ex post

After an event takes place.

FCC

Federal Communications Commission. The US regulatory body that regulates all inter-state and foreign communications by wire, radio and television. Intra-state communications are regulated by state public utilities commissions.

FRIACO

Flat Rate Internet Access Call Origination

IA

Indirect Access. The facility offered to customers which allows them to opt on a call by call basis for calls to be carried by an alternative operator.

Interconnection

The linking of one Public Electronic Communications Network to another for the purpose of enabling the people using one of them to be able (a) to communicate with users of the other one; (b) to make use of services provided by means of the other one (whether by the provider of that network or by another person).

Interoperability

The technical features of a group of interconnected systems which ensure end-to-end provision of a given service in a consistent and predictable way.

IP

Internet Protocol. The packet data protocol used for routing and carriage of messages across the internet and similar networks.

ISP

Internet Service Provider. A company that provides access to the internet.

Jumpering

The process of physically connecting the customer's access line to the terminating equipment in the local node.

LAN

Local area network. A network allowing the interconnection and intercommunication of a group of computers on a single site, primarily for the sharing of resources and exchange of information (e.g. email).

LLU

Local Loop Unbundling. A process by which BT's exchange lines are physically disconnected from BT's network and connected to other operators' networks. This enables operators other than BT to use the BT local loop to provide services to customers.

Local Loop

The access network connection between the customer's premises and the remote concentrator, usually a loop comprised of two copper wires.

MDF

Main Distribution Frame. The equipment where local loops terminate and cross connection to competing providers' equipment can be made by flexible jumpers.

MPLS

Multi Protocol Label Switching, an IP technology used in many virtual private network (VPN) services.

MSAN

Multi Service Access Node.

Narrowband

A service or connection providing data speeds up to 128kbit/s, such as via an analogue telephone line, or via ISDN.

NGN

Next generation network

NICC

Network Interoperability Consultative Committee

NTS

Number Translation Services. Telephone services using non-geographic numbers where that number is translated to a geographic or mobile number for final delivery to the called party.

Ofcom

Office of Communications. The regulator for the communications industries, created by the Communications Act.

Oftel

Office of Telecommunications, whose functions transferred to Ofcom on 29 December 2003.

PDH

Plesiochronous Digital Hierarchy. A transmission standard historically used for leased line services, now being replaced by SDH.

PPC

Partial Private Circuit; a wholesale network access product.

PSTN

Public Switched Telephony Network.

QoS

Quality of Service

SDH

Synchronous Digital Hierarchy. A transmission standard widely used for leased line services

Service provider

A provider of electronic communication services to third parties whether over its own network or otherwise.

SMP

Significant Market Power. This test is set out in the EU Framework Directive, and is aligned

with the competition law definition of 'dominance'. It is used by Ofcom to identify those operators who may be required to meet additional regulatory obligations.

TDM

Time Division Multiplexing.

Value chain

The sequential stages in production of a product or service.

Vertical integration

Mergers , or co-ownership between, producers that are active in different stages in the value chain for a particular good or service.

VoIP

Voice over Internet Protocol. A technology that allows users to send calls using Internet Protocol, using either the public internet or private IP networks.

Voice over Broadband

A Voice over Internet Protocol service provided over a broadband connection

VPN

Virtual Private Network. A technology allowing users to make inter-site connections over a public telecommunications network that is software-partitioned to emulate the service offered by a physically distinct private network.

WLR

Wholesale Line Rental. A regulatory instrument requiring the operator of local access lines to make this service available to competing providers at a wholesale price.