



**Award of available spectrum:
872-876 MHz paired with 917-921
MHz**

This document consults on the proposed grant of a wireless telegraphy licence to use this spectrum and on the associated auction process

Consultation

Publication date: 11 April 2006

Closing Date for Responses: 21 June 2006

Contents

Section		Page
1	Executive Summary	1
2	Introduction	5
3	Ofcom's duties and functions	8
4	Ofcom's objectives and proposed approach to the award	12
5	Spectrum packaging	18
6	Regulatory conditions, rights and obligations	25
7	Auction Design	37
8	Next steps and timetable	44
Annex		Page
1	Responding to this consultation	46
2	Ofcom's consultation principles	48
3	Consultation response cover sheet	49
4	Consultation question	51
5	Draft Licence	52
6	Impact assessment	66
7	Transmission rights	71
8	Summary of SFR:IP responses relevant to the award	75
9	Characteristics of adjacent band use	80
10	Glossary	81

Section 1

Executive Summary

- 1.1 As part of Ofcom's plans to implement its strategy of ensuring optimal use of the radio spectrum it has developed a programme of awards of wireless telegraphy licences that is designed to put available spectrum into the market. One such award is that of a wireless telegraphy licence for use of the spectrum band 872-876 MHz paired with 917-921 MHz. These frequencies are not currently licensed for use except for some non-operational use for test and development purposes.
- 1.2 This consultation sets out in detail Ofcom's proposals for the award of a wireless telegraphy licence to use these frequencies, in the light of responses it received to the Spectrum Framework Review: Implementation Plan consultation document published in January 2005¹.

Overview of the key proposals

- 1.3 Ofcom proposes, subject to the outcome of the current consultation, to hold an auction in early 2007 for the award of a national wireless telegraphy licence to use the spectrum band 872-876 MHz paired with 917-921 MHz.
- 1.4 The key elements of the proposed spectrum packaging and licensees' rights and obligations for the spectrum to be auctioned are as follows.
- One UK licence will be offered.
 - The licence will have an indefinite term with an initial period of fifteen years (during which time Ofcom's powers to revoke will be limited).
 - The licence will be tradable.
 - The licence will be technology and application neutral.
 - The licence will contain transmission rights and technical provisions designed to protect adjacent band users from harmful interference.
- 1.5 The key elements of the proposed award process are as follows.
- The auction will take the form of a single round sealed bid auction - each bidder will be able to submit one bid.
 - The winning bidder will be the one that submits the highest bid.
 - The auction will be based on a second price rule: the winning bidder will pay the price set by the next highest bid, or the minimum price if there is no other valid bid.
 - The minimum price for the licence will be £50,000.

Next steps

- 1.6 This consultation closes on 21 June 2006. Ofcom plans to hold a seminar on its proposals for interested parties in May or June.
- 1.7 After considering the responses to this consultation, Ofcom expects to publish the following key documents by the end of 2006:

¹ <http://www.ofcom.org.uk/consult/condocs/sfrip/sfip/>

- a short statement on this consultation;
- an Information Memorandum, describing in detail the relevant information for the award such as the award procedure and rules, prospective licence conditions and other information likely to affect use of the band;
- draft regulations setting out the auction rules;
- draft regulations to allow spectrum trading for this licence, including in respect of the wireless telegraphy register;
- a draft order for limiting the number of licences in the Spectrum Bands.

1.8 Ofcom will consider any comments it receives on the draft auction regulations before finalising them. The regulations will then be made to allow Ofcom to hold the auction. Before the auction is held Ofcom expects to hold a further seminar, in particular on the rules for the auction.

Detailed summary of Ofcom’s proposals

1.9 The table below sets out in summary form Ofcom’s proposals for this award.

Table 1 – Summary of Ofcom’s proposals

Spectrum Packaging	Ofcom's proposals
Number of licences	There will be one licence of 2x4 MHz awarded for use within the United Kingdom (this excludes the Isle of Man and the Channel Islands).
Wireless Telegraphy rights and obligations	Ofcom’s proposals
Maximum permissible EIRP	In the 872-876 MHz band, the maximum EIRP shall not exceed 33 dBm. In the 917-921 MHz band, the maximum EIRP shall not exceed 56 dBm subject to the additional conditions set out at paragraphs 6.2.
Out-of-band emissions	Out-of-band emissions shall be no more than the maximum levels set out at paragraphs 6.8.
Co-ordination	Separation distances from railway tracks within the potential scope of the GSM-R system for any base station operating at 917-921 MHz <ul style="list-style-type: none"> - 75 m for EIRPs of 32 dBm or less per transmission site - 250 m for EIRPs of more than 32 dBm per transmission site Specific measures in respect of GSM base stations operating at 910-915 MHz which are not equipped with duplexors, described at paragraphs 6.2. Some co-ordination may also be required with MoD use at 915-917 MHz and 921-925 MHz.
Duplex	In order to protect adjacent users from the risk of harmful

Award of available spectrum: 872-876 MHz paired with 917-921 MHz

arrangement	interference, a duplex arrangement will be required: <ul style="list-style-type: none"> - 872-876 MHz shall be used for base station receive; - 917-921 MHz shall be used for base station transmit.
Licence term	The licence will have an indefinite duration, with an initial term of 15 years during which Ofcom's powers to revoke will be limited. Ofcom will have the power to revoke for spectrum management reasons on no less than 5 years' notice after the initial period, which could lead to the licence being terminated the day after the expiry of the 15 year initial period or any time thereafter.
Licence fees	The auction will determine the fee payable for the licence. After the expiry of the initial period, if the licensee continues to hold the licence, there may be additional spectrum charges in line with Ofcom's policy on spectrum pricing at that time.
Spectrum trading	The licence will be tradable from issue. All types of trade - partial or total; concurrent or outright - will be permitted.
Award Mechanism and Rules	Ofcom's proposals
Auction format	The auction format will be a single round sealed bid.
Determining the successful bidder	The winning bidder will be the one that submits the highest bid.
Pricing rule	The winning bidder will pay the amount of the second highest bid made for the licence, or the minimum price if there is no other valid bid.
Transparency	There will be an application process for participation in the auction. The identities of the applicants will not be made public.
Prohibitions on bidder association and collusion	There will be specific rules to prohibit collusion but no rule limiting bidder association.
Minimum price	A minimum price of £50,000 will be set for the licence.
Deposits	An initial deposit of 50% of the minimum price will be required on application in the award process. Each bidder will be required to submit a further deposit at the same time as its bid. That further deposit must be such that the total amount in deposit at the time of bidding is equal to 50% of the bid made.
Payment terms	The winning bidder will be required to pay 100% of the fee by the date set in the Regulations, before the licence is issued.
Unsold licence	If the licence remains unsold, either through absence of bids or default, Ofcom will reconsider its approach to release of the spectrum, and will determine what course of action it considers appropriate at that time.

Award of available spectrum: 872-876 MHz paired with 917-921 MHz

Question: Do stakeholders agree with these proposals for the award of these frequencies or have any other comments on the contents of this document?

Section 2

Introduction

2.1 This document consults on Ofcom's plans for awarding a wireless telegraphy licence for use of the spectrum bands 872-876 MHz paired with 917-921 MHz (the "Spectrum Bands"). The proposals follow Ofcom's Spectrum Framework Review: Implementation Plan ("SFR:IP"), issued on 13 January 2005, which consulted on initial proposals to make a number of spectrum bands available to the market over the next few years, including the Spectrum Bands. That consultation closed on 24 March 2005.

Background

2.2 The proposals outlined in this consultation build upon those in the SFR:IP. They are designed to implement Ofcom's general approach to spectrum management which has been set out in a number of documents published by Ofcom, including:

- the Spectrum Framework Review consultation document published in November 2004 ("SFR") and Statement published in June 2005 ("SFR Statement")²;
- the Spectrum Trading consultation document published in November 2003 ("Trading Consultation Document") and Statement published in August 2004 ("Trading Statement")³;
- the Spectrum Liberalisation consultation document published in September 2004 ("Liberalisation Consultation Document") and Statement published in January 2005 ("Liberalisation Statement")⁴;
- the approach is also summarised in section 3 of the SFR:IP.

2.3 The licence award outlined in this consultation forms part of a wider programme of awards which was proposed in the SFR:IP. Ofcom's general approach to this programme was outlined in the Interim Statement on the SFR:IP published on 28 July⁵. Ofcom expects to publish more detailed documents with specific plans for each award as the programme advances, and corresponding statements. The first such consultation document, published alongside the Interim Statement, covered proposals for the award of 1781.7-1785 MHz paired with 1876.7-1880 MHz⁶. It was then followed by proposals for the bands 412-414 MHz paired with 422-424 MHz⁷, published on 13 October 2005, proposals for the award of 1785-1805 MHz in Northern Ireland⁸, published on 15 December 2005, and proposals for the award of 1452-1492 MHz, published on 31 March 2006⁹. The present document is the fifth in the series.

2.4 The Ofcom website includes a dedicated section for the spectrum awards programme which sets out relevant information and includes links to key documents for the programme and individual awards. Ofcom intends to use the section as the

² <http://www.ofcom.org.uk/consult/condocs/sfr>

³ http://www.ofcom.org.uk/consult/condocs/spec_trad/

⁴ <http://www.ofcom.org.uk/consult/condocs/liberalisation>

⁵ <http://www.ofcom.org.uk/consult/condocs/sfrip/statement/>

⁶ <http://www.ofcom.org.uk/consult/condocs/1781>

⁷ http://www.ofcom.org.uk/consult/condocs/spectrum_award

⁸ <http://www.ofcom.org.uk/consult/condocs/availspec/>

⁹ <http://www.ofcom.org.uk/consult/condocs/1452-1492/>

main point for provision of information on spectrum awards. Its address is <http://www.ofcom.org.uk/radiocomms/spectrumawards/>.

Availability of the Spectrum Bands

2.5 The spectrum available for award is 2 x 4 MHz with 45 MHz duplex spacing, i.e. 872-876 MHz paired with 917-921 MHz. The Spectrum Bands are free of incumbent users except for some non-operational users for test and development¹⁰ and is thus available immediately to support new uses. A number of technologies are used in adjacent bands:

- Below 915 MHz – European digital cellular radio (GSM, uplink);
- Above both 876 MHz and 921 MHz – MoD use in which sharing by Network Rail (GSM-Railways) is permitted;
- Below both 872 MHz and 917 MHz – MoD use;
- Below 870 MHz – Short Range Devices.

2.6 Figure 1 below illustrates the relative position of the available frequencies and adjacent uses.

Figure 1: the Spectrum Bands and adjacent spectrum

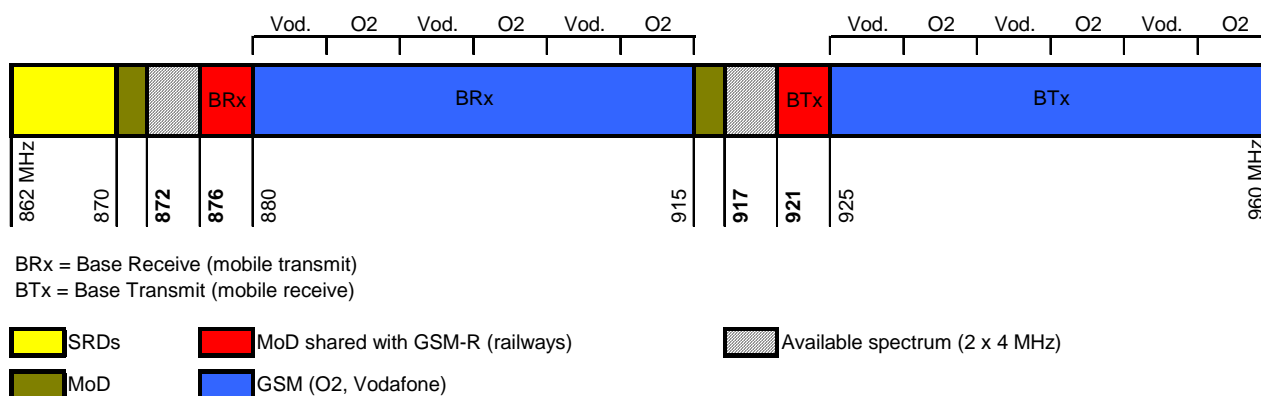

2.7 Ofcom's proposal is that future use in the Spectrum Bands is licensed in a way that provides a high degree of certainty to users in adjacent bands that they will be protected from harmful interference.

Matters covered in this document

2.8 The aim of this document is to provide as comprehensive a description as possible of Ofcom's proposals for the award of the Spectrum Bands at this stage. In particular it:

- describes Ofcom's objectives for the award;
- summarises responses to the proposals in the SFR:IP;
- describes the spectrum available for award and the main features of the award proposals;

¹⁰ Non-operational licences are issued for a short term and their holders must not cause interference to, and cannot claim protection from, other wireless telegraphy licensees.

Award of available spectrum: 872-876 MHz paired with 917-921 MHz

- sets out the proposed regulatory conditions for use of the Spectrum Bands, including transmission rights, key licence conditions and the applicability of trading and liberalisation;
- explains proposals for an auction of the spectrum, including the auction format and some key rules;
- includes a draft licence;
- sets out an impact assessment; and
- describes the technical considerations underlying the transmission rights.

Section 3

Ofcom's duties and functions

3.1 This section provides a brief overview of the main UK and European legislative provisions relevant to wireless telegraphy licensing and to the proposed award process. It does not provide a comprehensive statement of all legal provisions which may be relevant to Ofcom's functions and to the award of a wireless telegraphy licence for the use of the Spectrum Bands.

Ofcom's general duties

3.2 Under section 3(1) of the Communications Act 2003 it is the principal duty of Ofcom in carrying out its functions:

- (a) to further the interests of citizens in relation to communications matters; and
- (b) to further the interests of consumers in relevant markets, where appropriate by promoting competition.

3.3 In doing so, Ofcom is required to secure (under section 3(2)):

- (a) the optimal use for wireless telegraphy of the electro-magnetic spectrum;
- (b) the availability throughout the UK of a wide range of services;
- (c) the availability throughout the UK of a wide range of television and radio services which (taken as a whole) are both of high quality and calculated to appeal to a variety of tastes and interests;
- (d) the maintenance of a sufficient plurality of providers of different television and radio services;
- (e) the application in the case of all television and radio services of standards that provide adequate protection to members of the public from the inclusion of offensive and harmful material, unfair treatment in programmes and unwarranted infringement of privacy;

and to have regard to certain matters which include:

- principles of better regulation (section 3(3));
- the desirability of promoting competition (section 3(4));
- the desirability of encouraging investment and innovation (section 3(4)(d));
- the desirability of encouraging availability and use of broadband services throughout the UK (section 3(4)(e));
- the different needs and interests of persons in different parts of the UK (section 3(4)).

3.4 As the management of the UK radio spectrum is governed by the European Communications Directives, which aim to harmonise the regulation of electronic communications networks and services throughout the European Union, section 4 of the Communications Act 2003 requires Ofcom when carrying out its spectrum

functions to act in accordance with the “six community requirements” set out in that section when managing the wireless spectrum in the UK. Of relevance are the following:

- (a) The requirement to promote competition (section 4(3));
- (b) The requirement to secure that Ofcom’s activities contribute to the development of the European internal market (section 4(4));
- (c) The requirement to promote the interests of all persons who are citizens of the European Union (section 4(5));
- (d) The requirement to act in a technology neutral way (section 4(6));
- (e) The requirement to encourage to such extent as appropriate the provision of network access and service interoperability (section 4(7)); and
- (f) The requirement to encourage such compliance with international standards as is necessary for (a) facilitating service interoperability; and (b) securing freedom of choice for the customers of communications providers (sections 4(9) and (10)).

Ofcom’s duties when carrying out spectrum functions

3.5 In carrying out its spectrum functions it is the duty of Ofcom (under section 154 of the Communications Act 2003) to have regard in particular to:

- (a) the extent to which the spectrum is available for use or further use, for wireless telegraphy;
- (b) the demand for use of that spectrum for wireless telegraphy; and
- (c) the demand that is likely to arise in future for the use of that spectrum for wireless telegraphy.

It is also the duty of Ofcom to have regard, in particular, to the desirability of promoting:

- (a) the efficient management and use of the spectrum for wireless telegraphy;
- (b) the economic and other benefits that may arise from the use of wireless telegraphy;
- (c) the development of innovative services; and
- (d) competition in the provision of electronic communications services.

3.6 Where it appears to Ofcom that any of its duties in section 154 conflict with one or more of its general duties under sections 3 to 6 of the 2003 Act, priority must be given to its duties under those sections.

Granting wireless telegraphy licences

- 3.7 Ofcom's legal power to grant wireless telegraphy licences is set out in the Wireless Telegraphy Act of 1949. Section 1(1) of that Act makes it an offence for any person to establish or use any station for wireless telegraphy or to install or use any apparatus for wireless telegraphy except under and in accordance with a licence granted by Ofcom under that section (a wireless telegraphy licence).
- 3.8 Section 1(2) of that Act gives Ofcom the power to grant wireless telegraphy licences subject to such terms as Ofcom thinks fit.
- 3.9 However, Ofcom's broad discretion in relation to the terms that can be imposed in a wireless telegraphy licence is subject to the rule that Ofcom must impose only those terms that it is satisfied are objectively justifiable in relation to the networks and services to which they relate, not unduly discriminatory, and proportionate and transparent as to what they are intended to achieve (section 1D(9)).

Providing for an auction of wireless telegraphy licences

- 3.10 Under Article 5(2) of the Directive on the authorisation of electronic communications networks and services 2002/20/EC (the "Authorisation Directive"), when granting rights of use of radio frequencies (wireless telegraphy licences in the UK context), Member States must do so through open, transparent and non-discriminatory procedures.
- 3.11 Under Article 7(2) of the Authorisation Directive where the number of rights of use of radio frequencies needs to be limited, Member States' selection criteria must be objective, transparent, non-discriminatory and proportionate. (Section 164 of the Communications Act 2003 requires Ofcom to make an order setting out the criteria.)
- 3.12 Within that context, Ofcom has power under section 3 of the Wireless Telegraphy Act 1998 (having regard to the desirability of promoting the optimal use of the electromagnetic spectrum) to make regulations providing that applications for the grant of wireless telegraphy licences must be made in accordance with a procedure which involves the applicants making bids for licences (for example an auction).
- 3.13 Ofcom has broad powers in section 3(3) to make provision in regulations for the form of the licences and the auction bidding procedure.

Charging fees for wireless telegraphy licences

- 3.14 Ofcom also has power, under section 1 of the Wireless Telegraphy Act 1998, to prescribe in regulations fees that are payable in respect of wireless telegraphy licences. Under section 2 Ofcom may prescribe sums which are greater than necessary for the purpose of recovering costs, if it thinks fit in the light (in particular) of the matters to which they are to have regard under section 154 of the Communications Act 2003.
- 3.15 The fees for most wireless telegraphy licences are set out in such regulations (including those fees which are set by Ofcom in order to incentivise the use of the spectrum). The current regulations are the Wireless Telegraphy (Licence Charges) Regulations 2005 (SI 2005/1378).
- 3.16 Under Article 13 of the Authorisation Directive, any fees imposed for rights of use of radio frequencies shall reflect the need to ensure the optimal use of the resources.

Such fees must be objectively justifiable, transparent, non-discriminatory and proportionate in relation to their intended purpose (and take into account the objectives set out in Article 8 (Policy objectives and regulatory principles) of Directive 2002/21/EC¹¹ (the “Framework Directive”).

- 3.17 In the following sections of this consultation, Ofcom sets out its analysis of its proposals against its statutory duties and the general requirements applicable to licensing processes and licence conditions.

¹¹ The Directive of the European Parliament and the Council on a common regulatory framework for electronic communications networks and services (2002/21/EC)

Section 4

Ofcom's objectives and proposed approach to the award

Ofcom's approach to spectrum management

- 4.1 Ofcom has set out its approach to spectrum management in the SFR Statement. Its central theme is that the management of the radio spectrum can be carried out most effectively if market forces are harnessed to a significantly greater degree than in the past. In summary, Ofcom considers that this approach will:
- promote efficient use of the radio spectrum by allowing spectrum to be transferred to, and used by, the user who values it most highly;
 - promote competition by increasing the availability of spectrum for use by the most valuable service; and
 - facilitate economically valuable innovation as new users enter the market to offer new services.
- 4.2 The new approach is primarily implemented through the development and delivery of three policies:
- spectrum trading;
 - spectrum liberalisation; and
 - prompt release of unused or under-used spectrum into the market, allowing maximum flexibility for its subsequent use.
- 4.3 As explained below, Ofcom's proposals for the Spectrum Bands are designed to contribute to achieving its objectives within the framework of these policies.

Objectives for the award

- 4.4 The main objective for this award of a wireless telegraphy licence is to further the interests of citizens and consumers by promoting the optimal use of the spectrum, including the frequency bands 872-876 MHz and 917-921 MHz. In preparing the proposals designed to secure that objective, Ofcom has had and expects to have regard, in particular, to the availability of and demand for the spectrum and to the desirability of promoting:
- the efficient management and use of the spectrum;
 - the economic and other benefits that may arise from use of the spectrum;
 - the development of innovative services; and
 - competition in the provision of electronic communications services.
- 4.5 The SFR Statement identifies that in many circumstances the use of auctions is likely to be the most appropriate means of assigning spectrum that is not currently assigned where demand for the spectrum is likely to exceed supply. It also sets out the general view that wireless telegraphy licences for award should, so far as possible, include rights that are technology and usage neutral. Ofcom has followed this approach in framing the proposals for the award of the Spectrum Bands.

Choice of assignment mechanism

Licence exemption

- 4.6 Ofcom has a duty (under section 1AA of the Wireless Telegraphy Act 1949) to make regulations exempting particular equipment from licensing if it is satisfied that its use for wireless telegraphy is not likely to involve undue interference. Ofcom has considered whether use of equipment in the Spectrum Bands would be suitable for licence exemption.
- 4.7 Ofcom's technical analysis shows that specific provisions should apply to use of the Spectrum Bands to manage the risk of undue interference. This is explained further in section 6 and Annex 7. In summary, Ofcom has identified two main requirements for efficient use relevant to the issue of licence exemption:
- a specified duplex arrangement to manage the risk of interference with adjacent uses, with base transmit at 917-921 MHz and base receive at 872-876 MHz;
 - the requirement for separation distances from railway tracks (75 metres or 250 metres) and from certain GSM base stations (520 metres from those operating at 910-915 MHz and without a duplexor).
- 4.8 Ofcom is of the view that there would be significant risks of interference between users of the Spectrum Bands, and between these users and adjacent users, if use were exempt from licensing. This is because the number of unlicensed users could become very high and, even with low power limits, their systems are unlikely to coexist without harmful interference if their locations are not co-ordinated in some precise way. Ofcom's assessment is that available mitigation techniques would not be sufficient to appropriately reduce the risk of in-band interference in this context. Ofcom therefore believes that, for example, urban use of licence-exempt equipment would be highly likely to result in harmful interference. Therefore, licence exemption could result in significant costs and uncertainties for users.
- 4.9 Moreover, Ofcom's proposals for the conditions on use of the Spectrum Bands include separation distances from railway tracks, required to manage the risk of interference to the GSM-R service at 921-925 MHz, and some base stations, required to manage the risk of interference to GSM at 910-915 MHz. Ofcom believes that it would be impractical to ensure that separation distances are respected by users of the Spectrum Bands at 917 to 921 MHz if use of the Spectrum Bands were exempt from licensing. It might also be difficult to ensure that any potential co-ordination requirement with MoD use in adjacent bands would be effective.
- 4.10 Ofcom has also not found any evidence of demand for licence-exempt use of the Spectrum Bands, in particular from the market study it commissioned and responses to the SFR:IP. By contrast, it has found evidence of interest for the deployment of wide-area services which would typically require licensed access to the Spectrum Bands in the interests of efficient use.
- 4.11 Ofcom therefore does not plan to allow use of the Spectrum Bands by means of licence exemption.
- 4.12 However, as discussed at paragraph 6.13, Ofcom considers that mobile stations transmitting in the band 872-876 MHz could be exempt from licensing. Any exemption is likely to be subject to similar emission conditions as the licence.

Award of a limited number of licences

- 4.13 Ofcom has considered whether, if the Spectrum Bands are to be licensed, it is necessary to limit the number of licences available. In the SFR:IP, Ofcom set out its initial view that offering a single licence was the appropriate way to make the spectrum available in the interests of efficient use of the spectrum.
- 4.14 A high number of users of the two blocks of 4 MHz would require particularly strict co-ordination of their potentially varied uses and technologies, thereby imposing constraints on each user that could significantly limit the use of the Spectrum Bands in certain areas. Also, Ofcom is not aware of any demand for access to the Spectrum Bands under a large number of, or indeed several, distinct licences (for each less than 2x4 MHz) or under concurrent licences (with equal access to the Spectrum Bands).
- 4.15 Ofcom has therefore concluded that it is appropriate to limit the number of licences that should be awarded. Ofcom also considers that the amount of spectrum available and likely uses are such that the option of a single licence seems to be the most efficient and desirable one. This is discussed further in section 5.
- 4.16 Under Ofcom's proposals, there would also be scope for the licensee and the market to change this situation because all types of trades would be possible. The number of licensees in the Spectrum Bands could therefore be increased through concurrent or partial trades for example.

Award through an auction

- 4.17 Ofcom has considered what is likely to be the most efficient mechanism for awarding the licence for this band. It has set out, in the SFR:IP Interim Statement and in the SFR, its general view that an auction is likely to be its preferred mechanism for assigning unused or under-used spectrum. An auction is likely to be the most open, transparent and non-discriminatory way of releasing spectrum, using clear and simple criteria to identify eventual licensees among a number of candidates. Having considered the particular circumstances of the Spectrum Bands, Ofcom's proposal is that an auction mechanism should be used, but that the level of priority associated to the award should be proportionate to interest from potential users.
- 4.18 Ofcom considers that the clear and simple criteria to identify the winning bidders in an auction offer the most open, transparent and non-discriminatory method out of those available for determining the licensee for the Spectrum Bands. This is because in an auction, a bidding process is used to award licences to those bidders who attach the greatest value to their use. An auction is therefore likely to lead to the spectrum rights being assigned to users that value them most highly. These are the persons who are likely to make most efficient use. In this way an auction is the award mechanism most likely to secure the most efficient use of the spectrum.
- 4.19 In their report of February 2005¹², DotEcon and Analysys and Mason Communications (the "consultants") also identified an auction as the optimal assignment mechanism for the Spectrum Bands, subject to a potential phase of demand evaluation. Ofcom has considered the possibility of low demand and the risk of incurring internal costs in the preparation of an award. Overall, Ofcom is of the view that, as part of its programme of awards described in the SFR:IP, following

¹² DotEcon, Analysys and Mason Communications *Allocation options for selected bands*, completed in February 2005. See <http://www.ofcom.org.uk/consult/condocs/sfrip/sfip/band/bands.pdf>.

preparations for other spectrum bands, the marginal costs of preparing the award of these Spectrum Bands are likely to be sufficiently modest and these do not justify any significant delay in the award.

- 4.20 By contrast, in Ofcom's view, other assignment mechanisms are unlikely to be as efficient in promoting optimal use of the spectrum for this award if demand exceeds supply. Alternative assignment mechanisms include first come first served processes, where licences are assigned to applicants in the order of their application, and comparative selection processes, where licences are assigned to the applicants that, in the regulator's judgement, best satisfy the selection criteria that it has set.
- 4.21 A first come first served process would not be appropriate where demand for spectrum is likely to exceed supply, as the first applicant may not be the person who would make the most efficient use of the spectrum.
- 4.22 A comparative selection process involves defining selection criteria and assessing candidates' submissions against these. It therefore carries the risk of subjective judgements being made and of the spectrum not being awarded to the bidder best able to use it to maximum economic advantage.
- 4.23 Ofcom's proposal to use an auction as the method for assignment, and Ofcom's other proposals relating to the details of the auction design, are derived from the objectives for the award, and in particular the aim of securing optimal use of the spectrum. It is not Ofcom's objective to raise revenue by means of spectrum auctions nor, given Ofcom's statutory duties, is this a consideration that Ofcom has taken into account.

Timing of the award

- 4.24 Some respondents to the SFR:IP argued that Ofcom should hold back the award of this spectrum until there was strong evidence of market demand. The consultants suggested that Ofcom could consider that option. They alternatively suggested a preliminary demand evaluation stage to the auction in which potential users submitted initial applications, providing information which would assist Ofcom in deciding whether proposed uses of the spectrum were sufficiently valuable to justify assignment at the time.
- 4.25 The consultants identified O2 as a potential bidder that might acquire the rights in respect of the Spectrum Bands for the purpose of protecting their operations at 910-915 MHz from interference. The consultants suggested that, if this were the only source of demand, Ofcom might consider it preferable not to license the spectrum, pending future market developments. They also saw the possibility of a speculative purchase by an organisation which might then trade the Spectrum Bands to another party.
- 4.26 Ofcom has considered these points. It recognises that demand for the spectrum is uncertain and there is a risk that the proposed award might attract little interest from prospective bidders. It has therefore considered holding a period for receiving expressions of interest, in order to assess demand for the spectrum. If more than one expression of interest was received in this period, Ofcom would conduct an auction to award the spectrum. On the other hand, there is an argument that the lack of demand can only be truly tested by running an auction for the licence. This would allow interested parties to demonstrate whether or not there is demand for the spectrum. Under this argument, if Ofcom were to delay the holding of the auction on the assumption that there was limited demand, it would be substituting the

commercial judgement of the market with its own judgment of the level of demand. Since Ofcom is not likely to be in a better position than the market to ascertain all possible uses of the Spectrum Bands, the use of an auction is the best mechanism to allow the market to reveal whether or not there is demand for the Spectrum Bands. If there was speculative purchase by an organisation hoping to gain through a future sale, Ofcom considers that, in this particular case, such a speculator could play a key role in identifying new uses and facilitating more rapid deployment of services than if the award had been delayed. Also, Ofcom considers that the notice given to stakeholders on plans for the award with publication of the SFR:IP in January 2005 should allow them a reasonable period for exploring potential uses, as the award is expected to take place in early 2007.

- 4.27 Ofcom has included proposals on the design of the auction in this consultation with the aim of encouraging participation in the auction, which is likely to stimulate the emergence of valuable uses.
- 4.28 If Ofcom holds an award process and the licence remains unsold Ofcom will reconsider the position in light of circumstances at the time.

Services that may be provided and competition issues

- 4.29 Ofcom considers that releasing available spectrum into the market is likely to further the interests of citizens and consumers for a number of reasons. An award offers opportunities for additional capacity for services, additional innovation and competition. Ofcom considers that so long as there is any reasonable prospect of the spectrum coming into use, with benefits greater than the administrative costs of release, it would not be in the interests of citizens and consumers to leave the spectrum unavailable.
- 4.30 A range of potential services have been identified in both the consultants' analysis and responses to the SFR:IP. Most of these services are already available in the UK though typically they face a scarcity of suitable spectrum. These include mobile data or voice services, public safety applications, Programme Making and Special Events (PMSE), Private Mobile Radio (PMR), Public Access Mobile Radio (PAMR). The Spectrum Bands could provide additional capacity to support variants of such services.
- 4.31 Ofcom has considered competition issues in determining the packaging for this award (see paragraphs 4.29 to 4.33) and in particular its proposal to offer one national licence. Its view is that there is little likelihood of a position of market power being created or strengthened by a single user of the Spectrum Bands, since the services that may be provided through their use are expected to be similar to services provided using other bands. Any relevant market is likely to be wider than one comprising only services to be provided through the Spectrum Bands. If any concerns were to arise, Ofcom believes that such concerns could generally be addressed ex-post through competition law or sectoral regulatory powers.
- 4.32 Ofcom has also considered carefully whether the proposed licence terms will discriminate unduly against any other person, including existing licensees in other spectrum. Ofcom has concluded that the proposals do not involve undue discrimination. This is discussed in more detail in section 6, at paragraphs 6.34 to 6.42.
- 4.33 It should be noted that other wireless telegraphy licences granted in future, as part of Ofcom's ongoing award programme, may permit the provision of services that could

compete with those that may be offered using the Spectrum Bands. Ofcom is not proposing to place any limitation as a function of this award process on the scope for it to authorise other providers to use spectrum to offer such services. Such authorisation may occur by means of the award of new licences to use spectrum in other bands, by means of decisions as to licence exemptions or via the removal of unnecessary restrictions on the use of bands that have already been licensed. As set out in the SFR (and other documents mentioned at paragraphs 2.1 and 2.2 above), Ofcom's general policy is to move towards technology and application neutral licensing that provides much greater flexibility for the use of spectrum to respond to demand and to be economically efficient.

Future assignments in the Spectrum Bands

- 4.34 Ofcom has no plans to offer other licences for use of the Spectrum Bands, or to permit separate licence exempt use of equipment in the Spectrum Bands. At present, on the basis of information currently available to Ofcom, both the assignment of additional licences and the permission of licence exempt use are very unlikely. Ofcom would consult licensees and stakeholders on any proposals for assigning additional licences or allowing licence exempt use.

Section 5

Spectrum packaging

- 5.1 This section sets out Ofcom's proposal for packaging the rights to use the Spectrum Bands under a wireless telegraphy licence. In preparing these proposals, Ofcom has had regard to the most likely uses and, in light of these, to the extent to which the spectrum needs to be packaged to be put to the market.

Proposals in the SFR:IP

- 5.2 In the SFR:IP Ofcom explained that frequencies in the Spectrum Bands had been licensed to a company within the Inquam group for the national provision of a public telecommunications networks for its TETRA network. Following the operating company's entry into administration, the licence was revoked in July 2004. This meant that the frequencies became available for release to the market.
- 5.3 Ofcom proposed to award one UK licence that would be tradable and would contain no unnecessary constraints on the service to be provided or technologies to be used. In line with its general approach to the release of spectrum it believed that an auction would ensure that the band would be awarded to the operator likely to make the most efficient use of it. It considered that its proposals were consistent with the duty to secure the optimal use of the spectrum.
- 5.4 Ofcom indicated that it was undertaking further work on the award and had engaged independent advisers to complete a market study, assessing the different technologies and services that might be employed in the band. The consultants reported in February 2005.

Consultants' main findings and recommendations

- 5.5 The consultants considered a wide range of possible uses for the band in their assessment of likely demand for the spectrum. In principle the band could accommodate most mobile and wireless broadband technologies. Taking into account the amount of spectrum available they initially identified mobile technologies, such as CDMA2000, as the most likely. However, they considered that the requirement to manage the risk of harmful interference to GSM use, below 915 MHz in particular, undermined the viability of wide area or national CDMA deployment. The consultants also noted that GSM handsets are not available for the band, which limits the scope for wide area mobile services or would impose development timescales. Use for programme making and special events (PMSE), e.g. radio microphones, was also a possibility, though the band was not a core band for PMSE and there was no currently available equipment. In the light of the potential uses of the band, and restrictions on it, they considered that demand for the spectrum would be limited, perhaps to one or more potential mobile voice/data entrants. It might also be purchased speculatively, or by the adjacent GSM licensee as a guard band.
- 5.6 The consultants recommended that a single UK licence should be auctioned, using a sealed bid format, with two options for the pricing rule: first price (i.e. 'pay what you bid') pricing rule if there were concerns relating to bidder asymmetries or second price (i.e. 'pay the next highest bid value') otherwise. Also, they recommended that Ofcom should consider a pre-auction demand evaluation phase to assess whether it was appropriate to release the spectrum under prevailing market conditions.

Potential uses

- 5.7 On the basis of the consultants' report, of SFR:IP responses and its own analysis, Ofcom considers that potential uses for the Spectrum Bands include a number of technologies and services, although some uncertainty remains as to which are the most likely ones. These include mainly-
- voice and data services for mobile communications, probably similar to Public Access Mobile Radio or Private Mobile Radio, and including security applications, and possibly for public mobile services;
 - Programme Making and Special Events applications, for example for radio-microphones;
 - possibly Fixed Wireless Access services for broadband data and voice applications at fixed locations.

Technical constraints associated with the 917-921 MHz band – February Note

- 5.8 On 22 February 2005, Ofcom published a note (the "February Note")¹³ summarising its work on the potential technical characteristics for this band, and in particular the constraints that might be appropriate to address the potential for harmful interference to existing GSM networks in adjacent bands. The constraints were set out in Annex A to the February Note, with a power limit of 32 dBm EIRP per site. They would provide a high degree of certainty for adjacent users of the band 917-921 MHz (see Figures 1 and 2). The potential for blocking to O2 base stations would be limited to those with a separation distance of 20 metres or less and this could be addressed through good site engineering practice. Any technology might be used that complied with a spectrum mask designed to protect adjacent users, with specific separation requirements from railway tracks equipped with GSM-R for CDMA base stations. Ofcom has now carried out further analysis with the aim of maximising the flexibility for use of the Spectrum Bands. Its further proposals are set out below at paragraphs 6.2 to 6.9 and in Annex 7.

Responses to the SFR:IP proposals

- 5.9 In the SFR:IP, Ofcom asked whether it was agreed that Ofcom should award a UK licence for the Spectrum Bands on a technology and service neutral basis by auction.
- 5.10 A total of 28 responses were received. This section provides an overview of the responses and Ofcom's position on the main issues raised. A more detailed summary of responses and Ofcom's comments on them is included in Annex 8. Non-confidential responses have been placed on Ofcom's website¹⁴.
- 5.11 There was broad support for the proposals but some divergence of views, with suggestions for alternative approaches. In the main these either suggested facilitating a variety of possible technologies or holding back the spectrum until there was more evidence of demand.
- 5.12 Twelve responses supported the proposal for a national licence, though there were some differences in detail. For example, two responses suggested that the band be used for UMTS, while another believed that there should be no such use before

¹³ *Technical constraints associated with the 917-921 MHz band.* See <http://www.ofcom.org.uk/consult/condocs/sfrip/sfip/constraints/>.

¹⁴ See <http://www.ofcom.org.uk/consult/condocs/sfrip/sfip/responses/>.

2008. There was also a suggestion that the award should be in multiples of 2x1.3 MHz to allow the opportunity for an operator to deploy a technology with 1.25 MHz bandwidth (e.g. Flash-OFDM) and allow sufficient spectrum for the necessary guard bands. Two responses suggested geographic or local coverage areas.

- 5.13 Three responses questioned Ofcom's technical analysis of the band, in particular its work on the constraints that might be appropriate to avoid harmful interference to existing GSM networks. One considered that the February Note was flawed and the proposed restrictions would effectively prevent use of the band for wideband digital PAMR services. One believed that powers higher than those proposed would be justified and that further study was needed. One drew attention to the potential impact from non-GSM technologies on adjacent GSM-R use.
- 5.14 Four responses suggested holding back an award until there was evidence of demand, although another response suggested that there was no particular advantage in delay.
- 5.15 A number of responses identified specific uses for the band including PMSE, security applications and higher bandwidth services. However, another response suggested, alternatively, that the spectrum should be offered to the market with as much flexibility as possible.
- 5.16 One response suggested that technology neutrality could harm the prospects for TETRA.
- 5.17 With regard to auction design, one response suggested that cellular operators should be restricted from obtaining spectrum in the proposed auction. Another response did not support the proposal to have a first price, sealed bid auction arguing in favour of the ability to learn from other bidders' decisions in an open auction.

Number of licences and geographical coverage

- 5.18 Ofcom has considered some aspects relevant to the determination of the appropriate number of licences at paragraph 4.29 to 4.31. Ofcom considered whether the spectrum available should be split between a number of licences and whether regional or national licences should be offered. Demand for the spectrum is uncertain and, to some extent, it is unclear what technologies and services might be used. This means there is no obvious basis on which to package the available spectrum. The spectrum is, moreover, relatively limited and splitting it into smaller packages would limit the possibilities for its use, particularly as strict emission rights would be needed to prevent interference between packages. This would run counter to the efficient use of the spectrum and points to offering the Spectrum Bands as a single package. As Ofcom is proposing to make the licence tradable, allowing all types of trades described at paragraph 3.9 of the Trading Statement, it would be possible subsequently to partition the spectrum into smaller blocks if that appeared viable in the light of market and technological developments. In the light of technical considerations and current expressions of demand, Ofcom considers that the negative consequences of awarding several packages within the 2 x 4 MHz are likely to outweigh by far those of awarding one national licence.
- 5.19 Similar arguments apply to geographically defined licences. Given the uncertainty over future use of the band there is no basis or justification for offering a number of licences covering pre-determined geographical areas. Such geographical partitioning is also likely to inhibit efficient use of the spectrum, compared to a licence for the UK as a whole, because of the need to manage the risk of interference between the

various geographical zones at the boundaries. Spectrum trading will allow the geographical partitioning of the licence, if the licensee and other potential users see that this makes commercial sense. Ofcom has made clear in its publications on spectrum liberalisation that where licences are segmented by way of a trade, it will be a matter for the licensee who wishes to partition rights to define boundary conditions, and Ofcom will not expect to be involved in resolving any interference disputes that result.

- 5.20 Ofcom considers that offering a single UK licence, which would be fully tradable, would be consistent with the need to secure optimal use of the spectrum.

Technology and service neutrality

- 5.21 Two ECC Decisions are relevant to this band: ERC/DEC/(96)04 on the frequency bands for the introduction of TETRA; and ECC/DEC/(04)06 on the availability of frequency bands for the introduction of wide band digital land mobile PMR/PAMR systems in the 400 MHz and 800/900 MHz bands. The UK is not implementing either of these Decisions. As Ofcom has set out in a number of the documents identified at paragraphs 2.1 and 2.2, its preferred approach is to remove restrictions in existing wireless telegraphy licences that are no longer proportionate or objectively justified, enabling users to make better use of the spectrum and to introduce a wider range of services and technologies. Equally, when granting new wireless telegraphy licences Ofcom believes that, since technologies can change and develop over time, as a general principle it should not constrain future use of spectrum by being unnecessarily prescriptive in setting licence conditions, unless this is necessary for spectrum management reasons.
- 5.22 Ofcom considers that this approach is also supported by the fact that the Framework Directive requires that national regulatory authorities take the utmost account of the desirability of making regulations technologically neutral. As a consequence, Ofcom is required in section 4 of the Communications Act 2003 to meet a number of duties relating to “community requirements”. One of these is a requirement to act in a technology neutral way.
- 5.23 Consistent with this general approach, Ofcom intends to release the Spectrum Bands to the market with only those technology and usage restrictions that are the minimum necessary for the efficient management of the radio spectrum, the avoidance of harmful interference and compliance with Ofcom’s statutory duties and international obligations.
- 5.24 Ofcom’s technical analysis (which is summarised in Annex 7) indicates that it is not necessary to place any technology or usage restrictions on the 872-876/ 917-921 MHz bands other than power level, out-of-block emissions, separation distances from railway tracks and certain base stations and a specified duplex arrangement. Under technology neutral rights and obligations for use of the Spectrum Bands, the licensee will have the freedom to deploy a particular technology if it wishes, but it will not be required to do so. Ofcom considers that this is a proportionate and objectively justifiable approach, which provides the most appropriate means of meeting Ofcom’s objectives for the award and its duties under UK and European law. It is not unduly discriminatory as it avoids differential treatment of technologies or persons and is transparent in what it seeks to achieve.

Transmission rights and power limits

- 5.25 In determining technical rights and obligations under the licence, Ofcom considers that a basic principle should be that emission rights be set in a way that will give a high degree of confidence that undue interference is not caused to adjacent band users. This is because it considers that this is conducive to optimal use of the spectrum by having due regard to the risk that undue interference would cause to investment for the development of wireless networks and services. Ofcom has had to address a number of issues in applying this principle to the Spectrum Bands.
- 5.26 The 900 MHz band is for the most part assigned to the mobile cellular GSM operators, with Vodafone and O2 using the 880-915 MHz and 925-960 MHz sub-bands. That band is used extensively throughout Europe and elsewhere for GSM. It is also assigned to the GSM-R system used for the railway signalling and communications system licensed in the UK to Network Rail Ltd; Network Rail operate under a sharing agreement with MoD, who manage the bands 876-880 MHz and 921-925 MHz. MoD itself operates in those bands shared with Network Rail and in bands adjacent to the Spectrum Bands: 870-872 MHz and 915-917 MHz. The 917-921 MHz band that is presently available for assignment and adjacent bands are shown in Figure 2 below.
- 5.27 For the purposes of interference analysis, the paramount issue is adjacent use by O2 (910.1–914.9 MHz) and the licensee in the Spectrum Bands at 917-921 MHz. This is because the latter's base transmit band (BTx or downlink) will be separated by only 2 MHz from O2's base receive band (BRx or uplink). Other adjacencies do not involve reversed use, as both the 917-921 MHz and 921-925 MHz bands are base transmit band (BTx or downlink). This is shown in the band plans in Figure 1 above and Figure 2 below.

Figure 2: the 917-921 MHz band and adjacent spectrum

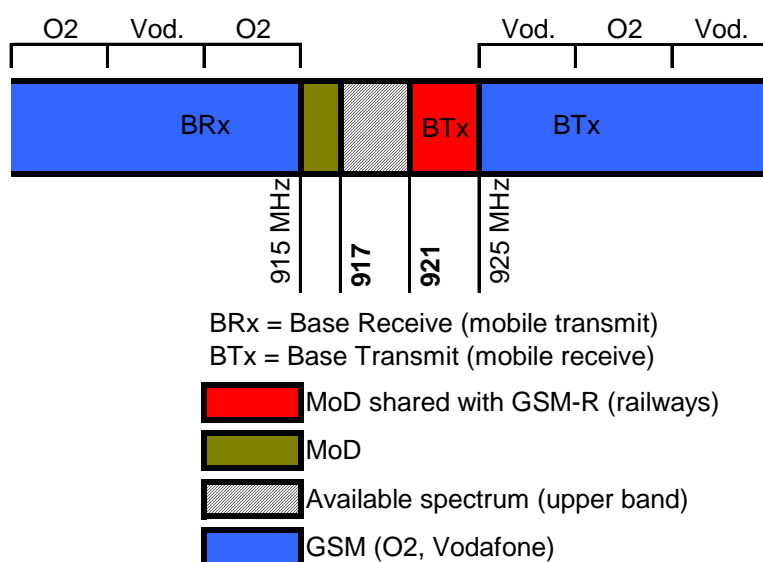

- 5.28 The adjacent uses between GSM-R and Vodafone, and between GSM-R and the 917-921 MHz band are relatively benign because all the respective operators are or will be required to use their assignments in the same uplink/downlink directions and thereby substantially reducing the scale of the interference experienced between themselves.

- 5.29 Conventional mobile bands are planned with a frequency separation between transmit and receive bands that reflects the technical characteristics associated with the transmitter and receiver of the radio system. This is termed a 'transition band'. Its purpose is to ensure the system can operate with minimal interference. ETSI produced technical specifications for GSM based on a 20 MHz transition band, which was subsequently reduced to 10 MHz. CEPT further reduced this to 2 MHz. It did so in the knowledge that mass development and deployment of GSM systems was well established and that, unless mitigation was adopted to protect adjacent GSM networks, the reduced transition band would probably cause high risks of interference into the GSM networks. CEPT's decision to allocate additional services in the transition band triggered a series of adjacent band compatibility studies to identify, for a number of candidate adjacent band sharers, what mitigation was necessary. The main conclusion of these studies was that mitigation could be effected primarily by additional filtering fitted to GSM base stations. The presumption was that co-ordination between the new entrant and the GSM operator(s) would be necessary.
- 5.30 Ofcom has taken into consideration uses adjacent to the 917-921 MHz band, and relevant CEPT reports, in preparing its proposals for transmission characteristics. As described in more detail at Annex 7, Ofcom considers that the following provisions are proportionate to its objectives for the award and adequately address the risk of harmful interference to existing assignments.
- Duplex direction: 917-921 MHz to be a base transmit (mobile receive) band.
 - Frequencies free of carriers: 920.8 to 921.0 MHz.
 - Maximum in-band power limit per site across the 4 MHz: 32 dBm + 10 dBm for each additional MHz or frequency left without carriers, up to a maximum of 56 dBm.
 - Out-of-band emissions: specific profiles as defined at Annex 7 and in the draft licence.
 - Separation distances between base stations and railway tracks within the scope of GSM-R systems operating at 921-925 MHz: 75 metres or 250 metres, depending on the in-band power used.
 - A separation distance in respect of a limited subset of GSM base stations operating at 910 to 915 MHz: those base stations not equipped with duplexors¹⁵ would require a separation distance of 520 metres (or possibly additional filtering) for emissions in the 917-921 MHz band at powers greater than 32 dBm EIRP per transmission site.
- 5.31 Ofcom believes that the number of base stations operating at 910-915 MHz and not equipped with duplexors is likely to be low. In addition, mitigation measures which could be employed seem likely to be limited in scope and cost. The reasons for this include that it will be possible, in a given location, for the future licensee in the Spectrum Bands to determine whether neighbouring base stations only have one antenna and therefore are equipped with duplexors by observing them without having full access to the equipment (although the presence of two paired antennas for a particular station does not imply that it is not equipped with a duplexor). Ofcom therefore considers that the mitigation measure relevant to these base stations is unlikely to create a significant burden on either the licensee in the Spectrum Bands or the adjacent GSM licensee. Ofcom's understanding is also that new GSM base stations which may be established in the future and use the 910-915 MHz

¹⁵ A duplexor is device which allows a transmitter operating on one frequency and a receiver operating on a different frequency to share one common antenna with limited interaction and degradation of the radio signals.

frequencies are unlikely to be of the same character and unlikely to be similarly susceptible to interference from transmissions at powers greater than 32 dBm (and up to 56 dBm) EIRP per transmission site in the upper half of the Spectrum Bands.

- 5.32 Ofcom's approach is based on a number of adjacent band compatibility studies undertaken by CEPT over the past few years. The interference level into O2 was consequently assessed as -125dBm, which would produce degradation in O2's network of less than 0.3 dB. Ofcom considers that the risk of undue interference into an adjacent GSM network associated with these conditions is low and acceptable. Ofcom's related analysis is summarised in Annex 7.
- 5.33 One respondent to the SFR:IP argued that low power restrictions would preclude use of the Spectrum Bands for wide area cellular services and it considered that use to be possible. Ofcom recognises that limiting the transmit power per base station for the 917-921 MHz band to 32 dBm would mean that wide area mobile services could be difficult to roll-out. Ofcom has therefore explored whether further flexibility could be considered for the licence to use the Spectrum Bands, compared to the proposals in the February Note, and it is proposing a graduated power limit, with a maximum of 56 dBm (subject to certain conditions). Furthermore, there may be scope for negotiation of further mitigation measures with the affected parties, which could allow higher powers in the Spectrum Bands. Ofcom believes that such negotiations are best conducted by the parties concerned, who should be able to agree, on a commercial basis, arrangements that meet their specific requirements.

Section 6

Regulatory conditions, rights and obligations

6.1 This section sets out the proposed technical and regulatory conditions specific to the wireless telegraphy licences that Ofcom proposes to award for use of the Spectrum Bands. The underlying principle has been to keep restrictions on use to the minimum necessary for efficient use of the spectrum and managing the risk of undue interference. Responses to the SFR:IP relevant to licence conditions are also addressed at Annex 8. A draft licence including the proposed licence conditions is at Annex 5.

Summary of technical licence terms

6.2 The main technical conditions in the draft licence are as follows.

- Internal guard bands
 - 920.8-921.0 MHz shall not form part of the occupied bandwidth of the transmission (i.e. to be free of carrier).
 - 875.8-876.0 MHz shall not form part of the occupied bandwidth of the transmission (i.e. to be free of carrier).
- Duplex direction imposed
 - 917-921 MHz: base transmit (mobile receive)
 - 872-876 MHz: base receive (mobile transmit)
- In-band maximum power limits
 - 917-921 MHz: 32 dBm + 10 dBm for each additional MHz of internal guard band, up to a maximum of 56 dBm EIRP per transmission site. A transmission site includes transmitters which use the same antenna or mast or transmitters which are located within 20 metres of each other.
 - 872-876 MHz: 33 dBm EIRP per mobile user station
- Out-of-band emissions: specified profiles for 917-921 MHz and 872-876 MHz
- Separation distance for transmitters operating at 917-921 MHz from railway tracks concerned with existing or future deployment of the GSM-R system
 - for a transmission site operating at a power of 32 dBm or less, 75 metres
 - for a transmission site operating at a power greater than 32 dBm EIRP, 250 metres.
 - In both cases, reduced distances may be negotiated case by case with Network Rail, the GSM-R licensee, for specific base stations (e.g. where building clutter obstructs the path to GSM-R systems).

Award of available spectrum: 872-876 MHz paired with 917-921 MHz

- A separation distance from GSM base stations operating at 910 to 915 MHz and not equipped with duplexors of 520 metres for transmission sites operating at 917-921 MHz. Reduced distances or the use of filtering as an alternative may be negotiated case by case with O2, the GSM licensee.
- Separation distances may also apply to the licensee in respect of MoD use in adjacent bands.
- The radio equipment shall be operated in compliance with such cross-border co-ordination and sharing procedures as may be considered necessary and notified to the licensee by Ofcom.

6.3 A summary of the transmission rights is set out in Annex 7.

6.4 The main non-technical conditions in the draft licence are:

- Licence term – indefinite duration, with an initial term of 15 years during which Ofcom’s powers to revoke would be limited;
- Tradability – the licence will be fully tradable;
- Liberalised use – the licence does not contain restrictions as to which technology can be used or which services can be offered in the Spectrum Bands.

6.5 The licence fee for the initial term will be determined by the award process.

6.6 The licence will permit use within the United Kingdom of Great Britain and Northern Ireland, but not in the Channel Islands or Isle of Man.

In-band power levels

6.7 The maximum in-band power levels for the Spectrum Bands will be defined as follows.

For the frequency band 872.0 to 876.0 MHz	
Across the 3.8 MHz of the permitted frequencies for the occupied bandwidth of the transmission	Maximum mean EIRP in dBm per mobile station within the licensed band
872.0 to 875.8 MHz	33

For the frequency band 917.0 to 921.0 MHz	
Across the 3.8 MHz of the permitted frequencies for the occupied bandwidth of the transmission	Maximum mean EIRP in dBm per transmission site within the licensed band
917.0 to 920.8 MHz	32 + 10 x GB*, limited to a maximum of 56 dBm

* Note: GB is the continuous frequency range, measured in MHz, from the frequency 917.0 MHz, which does not form part of the occupied bandwidth of the transmission (i.e. an additional internal guard band, to be free of carrier). If GB is greater than 2.4 MHz, the maximum value of 56 dBm EIRP per transmission site applies.

Out-of-block emissions

6.8 The maximum out-of block emissions for the Spectrum Bands will be defined as follows.

Below the permitted frequency band 872.0 to 876.0 MHz	
Frequency of measurement	Maximum mean EIRP in dBm/100 kHz
Below 870.0 MHz	-36

Above the permitted frequency band 872.0 to 876.0 MHz	
Frequency of measurement	Maximum mean EIRP per mobile station in dBm
876.0 MHz	-9
876.1 to 877.5 MHz	-27
877.5 to 878.7 MHz	-35
878.7 to 881.7 MHz	-37
Above 881.7 MHz	-43

Below the permitted frequency band 917.0 to 921.0 MHz	
Frequency of measurement	Maximum mean EIRP in dBm/200 kHz
916.9 MHz	2
915.0 to 916.7 MHz	-28
Below 915.0 MHz	-81

Above the permitted frequency band 917.0 to 921.0 MHz	
Frequency of measurement	Maximum mean EIRP per transmission site in dBm
921.0	14
921.1	-4
921.1 to 921.9 MHz	-13
921.9 to 922.5 MHz	-16
922.5 to 926.7 MHz	-23
Above 926.7 MHz	-29

Spurious emissions

6.9 The maximum spurious emissions from the licensed emissions, outside the Spectrum Bands, will be of -36 dBm/100 kHz mean EIRP density.

Potential changes of use of adjacent bands

- 6.10 It is possible that the use of bands adjacent to 872-876 MHz and 917-921 MHz may change over time, compared to the uses that are presently authorised. The use of the bands presently shared between MoD (for defence equipment) and Network Rail (for GSM-R) might for example change to other uses, and the use of the band presently used by O2 (for GSM) could also change.
- 6.11 Any change in the terms of any authorisations held by adjacent users would be subject to relevant regulatory approvals.
- 6.12 The proposals in this document have been prepared by Ofcom on the basis that the use that needs to be protected is the use that is currently authorised, not some possible future use which has not been authorised and which may only be one of a number of possible uses. This is consistent with the approach that Ofcom has said it will adopt in relation to the liberalisation of spectrum more generally.

Licence exemption for user stations

- 6.13 In principle, Ofcom considers that mobile user stations transmitting in the band 872–876 MHz could be considered for addition to those mobile stations covered by licence exemption regulations¹⁶. At present, it is not clear that there is a need to do so in the light of potential uses for the Spectrum Bands. Generally, Ofcom would expect that, if a use emerged that pointed to the extension of the existing licence exemption, it would consider the requirement as part of its process of consultation for amending the licence exemption regulations. The proposals for technical conditions for licence exemption of mobile station would likely be those applicable to mobile stations under the licence for the Spectrum Bands (as summarised at paragraph 6.2 and described in more detail at Annex 7).

Resolution of interference with licence holders in adjacent spectrum

- 6.14 It is the responsibility of parties interested in using the Spectrum Bands to carry out their own assessment of the potential for interference between use in the Spectrum Bands and adjacent uses. The licensee in the Spectrum Bands should ensure that it does not cause harmful interference to adjacent users of the radio spectrum.
- 6.15 Information about adjacent uses is referenced at Annex 9.
- 6.16 If any interference with adjacent licensees is reported, Ofcom will expect the licensee in the Spectrum Bands to co-operate with the adjacent licensees to resolve the issue. If they are unsuccessful in doing so, Ofcom may take action to resolve the issue.

¹⁶ Statutory Instrument 2003 No. 74, the Wireless Telegraphy (Exemption) Regulations 2003.

Interference between users in the UK and neighbouring countries

- 6.17 At present, the UK has not entered into any cross-border co-ordination agreements that cover the Spectrum Bands. It expects to do so, if necessary, when the conditions for their use will be finalised. It expects that the agreements would specify the field strength at the border that can be radiated into the territory of the neighbouring country, in preferred and non-preferred channels. Permitted field strengths are higher for preferred channels than for non-preferred channels.
- 6.18 Ofcom will expect the licensee to respect the field strength requirements, including for non-preferred channels, contained in any future agreements negotiated with neighbouring countries.
- 6.19 Where authorised uses in neighbouring countries are operating within the terms of cross-border co-ordination agreements, Ofcom cannot offer any protection to the licensee operating in border areas.
- 6.20 It should be noted that internationally (in the ITU Radio Regulations¹⁷) and as far as Europe is concerned, the Spectrum Bands under consideration are allocated to the FIXED and MOBILE¹⁸ (except aeronautical mobile) services. Although Ofcom's intention is to offer the spectrum on a technology and application neutral basis, licensees who intend to offer services outside the relevant FIXED and MOBILE definitions should be aware that they will be operating under article 4.4 of the Radio Regulations which enshrines the principle that such use shall not cause harmful interference to, and shall not claim protection from harmful interference caused by, a station operating in accordance with the provisions of the Radio Regulations. Therefore, if any use in the Spectrum Bands other than FIXED or MOBILE (except aeronautical mobile) caused interference to users in other countries respecting the ITU allocation, Ofcom might have to take appropriate steps to secure compliance with the UK's international obligations. Also, if licensees in the Spectrum Bands, with uses other than FIXED or MOBILE, suffered interference from services abroad that complied with the ITU allocation, they might have to accept such interference.

Licence term

- 6.21 It was proposed in the SFR:IP that new licences to be awarded by auction should generally have an indefinite term with an initial period. During the initial period the grounds for revocation by Ofcom would not include a general power to revoke for spectrum management reasons. After the end of the initial period, the grounds for revocation by Ofcom would include such a power, subject to a minimum notice period of five years. Ofcom also proposed that notice of revocation for spectrum management reasons could be given so that the licence ended the day after the expiry of the initial period.
- 6.22 The aim of these proposals was to provide licensees with an initial period during which they would have high security of tenure, and grounds for revocation would be limited to a narrowly defined set of conditions. The period of the initial term should be

¹⁷ Radio Regulations of the International Telecommunication Union, edition of 2004 at time of publication of this consultation document.

¹⁸ A fixed service is a radiocommunication service between specified fixed points. A mobile service is a radiocommunication service between mobile and land stations, or between mobile stations. The services are marked in capital letters as they have primary status, which in summary provides them protection from interference from other services. Further definitions are provided in the Radio Regulations.

linked to a reasonable view of the period required to earn a return on the investment anticipated for efficient use(s) of the spectrum. The aim of proposing an indefinite duration was to give the licensee the opportunity to continue operating its business beyond the initial term. However, during this period Ofcom would be able to recover the spectrum by serving a notice of revocation in a similar manner to many other spectrum licences, if this step was justified on spectrum management grounds.

6.23 Consistent with the Interim Statement on the SFR:IP, Ofcom proposes to take the following approach to the award of the Spectrum Bands.

- The licences will have an indefinite duration.
- The licences will have an initial term of 15 years.
- The licences may be revoked before the expiry of the initial term on the limited grounds set out below in paragraph 6.28.
- The licence may be revoked from any point after the expiry of the initial term on the grounds set out in paragraph 6.28. It may also be revoked for spectrum management reasons subject to Ofcom giving five years notice. Notice of revocation may be issued during the initial term, for revocation to take effect after expiry of the initial term.

Figure 3: graphical illustration of the licence term

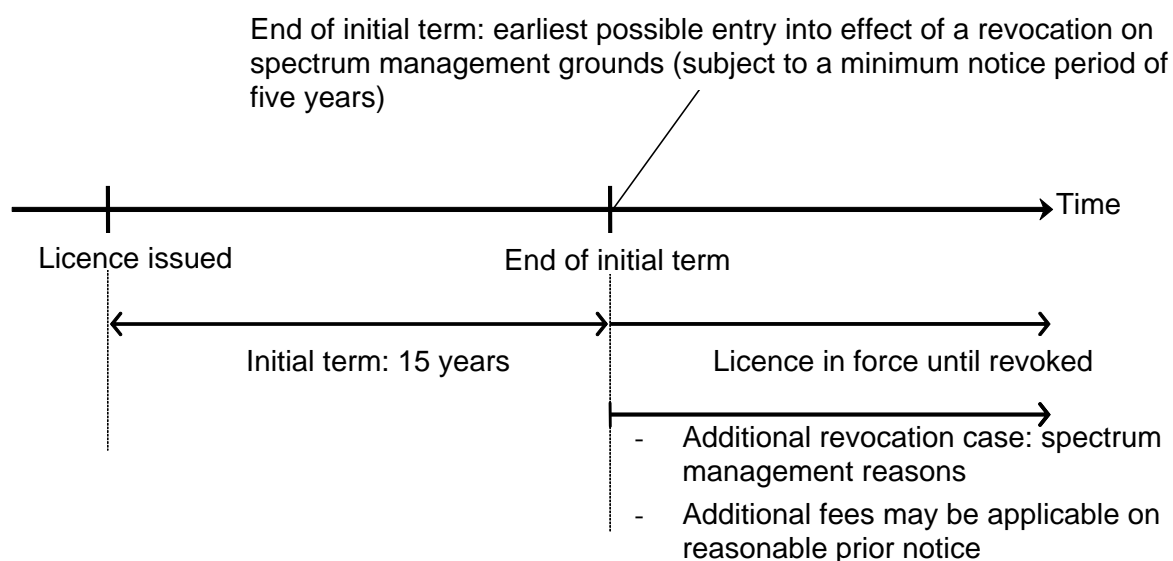

Duration of the initial term

6.24 The proposed initial term is designed to provide the licensee with a high security of tenure for investment planning purposes. During that period, Ofcom will not be able to revoke the licence for spectrum management reasons and will only be able to do so in the particular circumstances described in paragraph 6.28.

6.25 To determine the length of the initial term, Ofcom has considered the relevant period that is likely to provide a reasonable chance for the businesses that might be most likely to operate in the Spectrum Bands to make a return on their investment. This is based on assessments of such factors as:

- initial fixed costs and operating costs to exploiting the spectrum;
 - the time needed to roll out an operational service;
 - projected rates of uptake of services and associated revenues.
- 6.26 Ofcom has taken into account the market consultants' business modelling. In summary, they determined that it was unlikely to recoup an investment in a wide area network over a period of ten years. They considered that this could change if optimistic assumptions of service adoption were made, with a new entrant then having a commercially viable case by 2015 for a wide area mobile network. Taking into account both the uncertainty over potential uses and limited amount of spectrum involved, Ofcom considers that it would likely be beneficial to the efficient use of the Spectrum Bands to offer an initial term of 15 years. However, it does not consider that there is evidence that a longer term is warranted for the circumstances of these bands. Beyond the initial term, Ofcom proposes an indefinite duration, subject to revocation in specified circumstances.
- 6.27 A discussion of alternative options, and why Ofcom has chosen this option as the most likely to allow the broadest range of potential bidders and uses, is included in the Impact Assessment which forms Annex 6 to this document.
- 6.28 During this initial term the licence may only be revoked for the following reasons:
- with the consent of the licensee;
 - for non-payment or late payment of the relevant licence fee;
 - if there has been a breach of any of the terms of the licence;
 - if the licensee has not complied with any requirement of any relevant trading regulations;
 - if the licensee has not complied with the auction regulations under which the licence was awarded, including any financial provisions for example on guarantees;
 - in accordance with section 4(5) of the Wireless Telegraphy Act 1998. That section provides that notwithstanding any terms or provisions in a Wireless Telegraphy Act licence which restrict the exercise by Ofcom of its power to revoke licences, Ofcom may at any time, by notice in writing, revoke or vary licence terms if it appears to be requisite or necessary or expedient to do so in the interests of national security, or for the purposes of complying with a Community obligation of the UK or with any international agreement or arrangements to which the UK is party; and
 - if it appears requisite or necessary or expedient to do so for the purpose of complying with a Direction by the Secretary of State to Ofcom under section 5 or section 156 of the Communications Act 2003.

After the initial term

- 6.29 When the initial term has expired, the licence will remain in force and continue to be held by the licensee. Two additional conditions will then also apply:
- one providing an additional power for Ofcom to revoke the licence on spectrum management grounds as described above; and
 - one allowing Ofcom to apply annual licence fees.
- 6.30 Whether an annual licence fee is applied after the expiry of the period of the initial term will depend on Ofcom's general approach to fees for the use of spectrum at that time and how that general approach relates to the licence for the Spectrum Bands.

Such fees could be set at a level to recover a share of the costs of regulation; it may alternatively be based on Administered Incentive Pricing (AIP). This provision will allow for the potential application of AIP to the licensed use of the spectrum after the end of the initial term if this is appropriate in the context of Ofcom's statutory duties. AIP presently plays an important role in incentivising efficient spectrum management, and Ofcom has stated that it expects to continue applying AIP after introducing spectrum trading in order to promote efficient use of the spectrum.

- 6.31 Ofcom does not consider that it is necessary or appropriate to specify now the level of the annual licence fees, if any, that may be applied to the Spectrum Bands after the end of the initial term. Ofcom would expect to bring forward proposals on this matter to a timescale that gave the licensee reasonable notice of any relevant fees before they became payable.
- 6.32 Ofcom believes that it is necessary to include these additional licence conditions in relation to the licence period after the initial term because of the need for the regulator to be able to intervene if required to promote efficient use of the spectrum. Ofcom has a high degree of confidence that the auction, including the payment of the auction fee, will secure efficient use of the spectrum during the initial term. However, it is less clear that this objective will be met after the initial term, or indeed for the entire indefinite duration of the licence. The longer the period over which the regulator is required to look forward, the greater the uncertainty that exists. At present, the ability to revoke licences on spectrum management grounds, and the ability to charge fees (including to promote optimal use of the spectrum) are important mechanisms in the regulator's toolkit. Ofcom considers that it is proportionate and objectively justifiable to include provisions allowing the regulator to take these steps after the end of the initial term of this licence. Ofcom also considers that the inclusion of these provisions is transparent as to what it seeks to achieve and does not unduly discriminate against any person.
- 6.33 It is important to note that Ofcom would expect to give prior notice at the time of any specific proposal to use the power of revocation, or the charging of fees, and to consult as appropriate.

Justification of the terms and consideration of discrimination

- 6.34 Ofcom believes that the proposed conditions meet its statutory requirements, as set out in section 3, in particular the requirements only to impose terms that are objectively justified, non-discriminatory, proportionate and transparent.
- 6.35 In setting these terms, Ofcom has taken into account the available technical and economic evidence on the likely use of the band and believes that these terms represent the minimum necessary to ensure efficient use of the radio spectrum and therefore they are objectively justified.
- 6.36 Ofcom considers that setting a maximum power of 56 dBm EIRP per transmission site (base transmit) and a maximum power of 33 dBm EIRP per mobile station will optimise compatibility of adjacent band use while maximising the scope for use of the Spectrum Bands. The reasoning for this proposal is set out in section 5 (paragraphs 5.25 ff) and in Annex 7.
- 6.37 The initial licence term specified is likely the most appropriate for the range of services that may be deployed in the Spectrum Bands, taking account of corresponding uncertainties. The proposal preserves Ofcom's discretion on notice to revoke the licence for spectrum management reasons after the initial term, if it

becomes necessary to do so. The proposed provisions on licence fees are objectively justified because they will either be determined by the applicants or bidders themselves in the award (see section 7 for auction details) or if, as indicated above, following the expiry of the initial term other licence fees are payable, these will be justified to ensure continued efficient use of the Spectrum Bands or to recover a share of the regulatory costs.

- 6.38 Ofcom also believes that these licence conditions are proportionate since they are, in its view based on the evidence available, the minimum set of restrictions which is required to promote efficient use of the Spectrum Bands and the other objectives relevant to this award process. The proposed licence conditions are also transparent in that they are clear as to their purpose and they are set out in the draft licence which is included in Annex 5.
- 6.39 Ofcom has also considered carefully whether the proposed licence terms will discriminate unduly against any other person, including existing licensees in other spectrum. Ofcom has concluded that the proposals do not involve undue discrimination.
- 6.40 On the issue of undue discrimination, the mobile network operators (MNOs) commented in some detail in response to the SFR:IP consultation with arguments they applied to all spectrum bands for award. Some argued that offering new spectrum licences to the market, along the lines proposed in the SFR:IP, could give rise to undue discrimination against existing licensees. These points were made by some existing 2G MNOs in particular. In some cases, these comments were linked to other objections to Ofcom's proposals, such as the need for a number of pre-conditions to be met before any further spectrum awards could reasonably proceed.
- 6.41 Those MNOs who raised the issue of undue discrimination pointed to various licence characteristics such as those proposed in this consultation (technology- and use-neutrality, indefinite term, tradability and absence of roll-out obligations). They argued that the inclusion of terms on these lines in any new licence could unduly discriminate against existing 2G and 3G licensees because the existing 2G and 3G licences contain terms that are less advantageous.
- 6.42 Ofcom does not consider that the proposals included in this document involve any undue discrimination against the holders of 2G and 3G licences, or of any other existing licence. This is because the licence that Ofcom proposes to offer in the Spectrum Band is different in numerous respects from existing 2G, 3G and other licences. By way of example, it differs in relation to the quantity of spectrum available, the characteristics of the relevant frequencies and the international regulatory environment, among other respects. The licence proposed for the band constitutes a different type or class of licence from those already that exist for 2G and 3G services, with rights that are different from the existing 2G and 3G licences. The proposals made by Ofcom in relation to the 872-876 and 917-921 MHz bands are, moreover objectively justified. Ofcom considers that there can therefore be no undue discrimination against existing 2G or 3G licensees. Also, it should be noted that Ofcom is not proposing to place any restrictions in the auction rules on the holders of 2G or 3G licences (or for that matter any other person) from participating in the auction and competing to acquire the licence.

Spectrum trading

- 6.43 Ofcom has started the implementation of spectrum trading for selected licence classes in 2004, through the Wireless Telegraphy (Spectrum Trading) Regulations

2004¹⁹. The changes, described in the Trading Statement, published in August 2004, introduced the possibility for licensees in specific classes to carry out:

- outright total transfers, i.e. transfers of all of the rights and obligations arising under a licence to a third party;
- concurrent total transfers, i.e. transfers (of all of the rights and obligations arising under a licence) to a third party which result in a concurrent holding of those rights and obligations by the transferor and the transferee(s);
- outright partial transfers, i.e. outright transfers of some of the rights and obligations arising under a licence to a third party; and
- concurrent partial transfers, i.e. transfers of some of the rights and obligations arising under a licence to a third party which results in a concurrent holding of those partial rights and obligations by the transferor and the transferee(s).

6.44 The exhibit below gives some illustrative examples of the types of transfers that are possible.

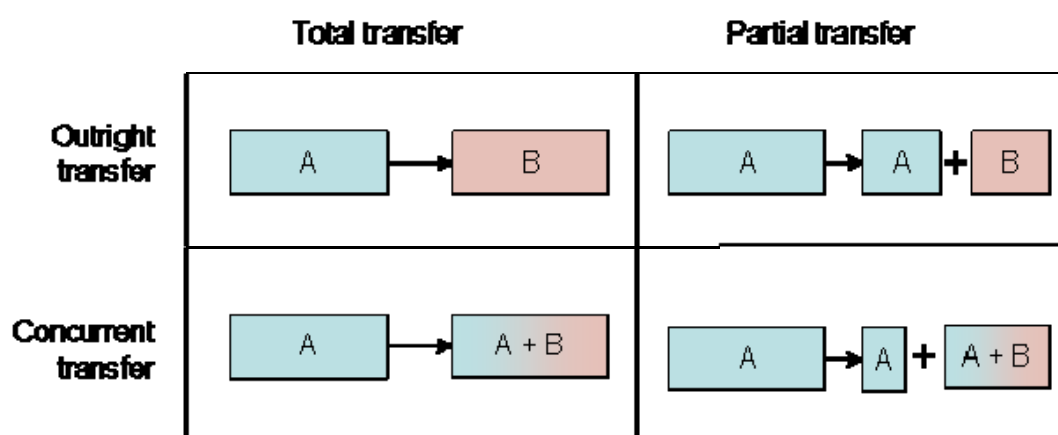

6.45 In the case of the Spectrum Bands, Ofcom proposes to amend the Wireless Telegraphy (Spectrum Trading) Regulations to allow all these types of transfer.

Liberalised use of the Spectrum Bands

6.46 In January 2005, Ofcom published a statement on spectrum liberalisation, describing changes in the way licensees of particular licence classes can use the spectrum. These changes, programmed for the year 2005, are being implemented in stages to facilitate the optimal use of the spectrum. The full statement and associated documents can be found at: <http://www.ofcom.org.uk/consult/condocs/liberalisation/> and <http://www.ofcom.org.uk/radiocomms/ifi/trading/libguide/>.

6.47 The spectrum liberalisation process described in the statement includes changes to three licensing sectors in 2005 – Business Radio, Fixed Wireless Access and Fixed Links – and the use of two mechanisms for liberalisation of spectrum use – through individual licence variation, following a request by a licensee, or through a generic licence change applied by Ofcom. The licence proposed for award in the Spectrum Bands will bear conditions similar in principle, in terms of technology neutrality and ability to change use, to those that Ofcom would aim to introduce through a generic change to existing licences in a given class or sector.

¹⁹ Statutory Instrument 2004 No. 3154 amended by Statutory Instrument 2006 No. 339.

- 6.48 In the SFR:IP, Ofcom indicated its plan to award the Spectrum Bands without restrictions as to service provision or technology other than the power limit. The spectrum mask specified to that effect and additional technical conditions, described in Annex 7, will allow the licensee in the Spectrum Bands to transmit while minimising the risk of causing interference to adjacent licensed users. The licensee will be free to deploy the technologies of its choice and change its use of the spectrum or these technologies within the licence conditions, without requiring Ofcom's approval.
- 6.49 Any change by a licensee in the band that would depart from its licence conditions (e.g. power level and out-of-block emission mask) will be subject to prior approval by Ofcom. The same will apply to any change by licensees in adjacent bands that would depart from the conditions in their licences. Ofcom will consider any requests for change on their merits at the time.

Sitefinder

- 6.50 Sitefinder is the national database of mobile phone base stations. It was established in response to one of the recommendations of the Group of Independent Experts led by Sir William Stewart which investigated possible hazards posed by mobile phone technologies on behalf of the Government and which reported in May 2000. The Group recommended that reliable and openly available information about the location and operating characteristics of all base stations should be provided by Government. Sitefinder fulfils this recommendation. Ofcom has inherited the responsibility for providing the database on behalf of the Government from the Radiocommunications Agency, which was formerly part of the Department of Trade and Industry.
- 6.51 The database provides information on all operational GSM, UMTS and TETRA base stations in England, Scotland, Wales and Northern Ireland. Indoor sites in public places such as airports, shopping centres and railway stations are included. The database is provided in the form of an internet website²⁰ utilising a map driven interface which allows users to see graphically the position of base stations nearest to any location of interest. Brief technical details of each base station can be obtained by clicking on the base station's icon on the map.
- 6.52 Sitefinder relies on operators voluntarily providing Ofcom with detailed information about each of their sites on a regular basis (currently this is approximately every quarter). The type of information supplied includes:
- the transmit power (dBW);
 - location (in the form of a 10 digit NGR and a postcode);
 - height of the antenna above ground level (m);
 - the frequency band of operation (e.g. 1800 MHz);
 - the technology (i.e. GSM, UMTS, TETRA), etc.
- 6.53 Ofcom has asked the Government for its views on the relevance of Sitefinder to spectrum awards. The Government has advised that it continues to view Sitefinder as an important resource for consumers. Provision of information about the location of base stations is useful in the planning system, but also helps to inform the public and encourage discussion about mobile technology based on factual evidence.

²⁰ <http://www.sitefinder.radio.gov.uk>

Award of available spectrum: 872-876 MHz paired with 917-921 MHz

- 6.54 The Government has also advised that it considers that if the holder of the licence for the Spectrum Bands uses one of the technologies currently covered by Sitefinder, it should be invited to participate voluntarily in the database.
- 6.55 Consistent with this advice, it is therefore Ofcom's intention to invite the holder of the licence for the Spectrum Bands to participate on a voluntary basis in providing information about their base stations for inclusion on Sitefinder where they are using one of the technologies currently covered (i.e. GSM, UMTS or TETRA). It is possible that the Government might in future seek the agreement of licence holders, including in this spectrum, to expand the scope of Sitefinder to include technologies beyond those currently included.

Section 7

Award design

- 7.1 In the SFR:IP Interim Statement Ofcom set out its policy on the release of spectrum. Two of its key elements were that:
- auctions are generally the best mechanism for awarding licences where demand is likely to exceed supply;
 - auction design will match the circumstances for each award and will aim to achieve an efficient outcome within a simple design.
- 7.2 Ofcom has set out in section 4 its view that an auction is the most appropriate way of awarding the Spectrum Bands. This section sets out the particular auction design that Ofcom proposes to use for this award.
- 7.3 Ofcom received advice from DotEcon, Analysys and Mason Communications in a report on the award of these and other bands that was published in February 2005 (see paragraph 4.19). They recommended that, if Ofcom were to award a single UK-wide licence, it might be suitable for assignment by auction. A first price, sealed bid format would be simple to implement and should be more robust to low competition scenarios than other formats. It would be suitable even if there were only one bidder, so long as Ofcom did not disclose the number of participants. In the event that there were more than two bidders, an Anglo-Dutch hybrid auction (combined ascending bid/sealed bid format) might improve the efficiency of the sealed bid process.
- 7.4 Detailed rules for the auction will be contained in regulations that Ofcom plans to publish in draft as a result of this consultation process. They will also be set out in the Information Memorandum to be published about the same time.

Auction format

- 7.5 In deciding whether to accept the consultants' recommendation of a first price sealed bid auction, or possibly using an Anglo-Dutch hybrid, Ofcom has looked at the pros and cons of each in the light of the particular circumstances of this award. The following analysis is based on the presumption that only one licence will be awarded.
- 7.6 **Single-round, sealed-bid auctions** are simple, quick and cheap to run. On a designated date, and by a specific time (the submission deadline), each bidder submits a bid, in a manner that precludes any other party (including bidders and the auctioneer) from immediately knowing the contents of the bid (e.g. the bid is submitted in a sealed envelope). All bids are kept sealed and secure by the auctioneer until the submission deadline has passed. Once the deadline has passed, the auctioneer opens the bids, examines them, and determines the result of the auction, i.e. the identity of the winning bidder and the price that it will have to pay. It is important to note that there is no opportunity for bidders to revise their bids once the submission deadline has passed; in particular, there is no opportunity for bidders to increase their bids in the light of the bids made by other bidders in the auction.
- 7.7 A key aspect of the design of a single-round sealed-bid auction is how the final price to be paid is determined. For an auction with a single lot, there are two main alternative pricing rules:
- in a first-price auction, the winner pays the amount that they bid;

- in a second-price auction, the winner pays the amount of the next highest bid (i.e. the highest losing bid) or the reserve price if there is no other valid bid.
- 7.8 The choice of **pricing rule** may have significant implications for the outcome of the auction because of its influence on the behaviour of bidders in the auction.
- 7.9 Ofcom has considered below, at paragraphs 7.15 to 7.19 the pros and cons of both first-price and second-price single-round, sealed-bid auctions.
- 7.10 **Multi-round, open, ascending bid auctions** for single lots are also relatively familiar and easily understood. They are preferred in cases where there is common value uncertainty and the efficiency of the auction can be enhanced from bidders learning from each other's bids. The auction proceeds through a series of rounds. In each round an asking price is announced and bidders decide whether or not they are willing to pay the current asking price. As the rounds proceed the asking price is progressively increased, until only one bidder is left that is willing to pay the final asking price. This one remaining bidder is the winner and it has to pay the final asking price. Often, the identity of the bidders remaining in the auction (willing to pay the current asking price) is revealed at the end of each round, but it is also possible to limit transparency. Provided that the increase in the asking price between consecutive rounds is modest, the winner in a multi-round, open, ascending bid auction will normally only pay a small amount in excess of the maximum amount that the bidder with the second-highest valuation was willing to bid.
- 7.11 An **Anglo-Dutch hybrid** auction is a variant of the multiple round ascending auction. The distinguishing feature is that the final round is in the form of a sealed bid. The final round is usually determined when the number of bidders remaining is just one more than the number of licences on offer. In principle this format combines the efficiency property of the multiple round auction, where bidders are able to refine their valuations as they observe the behaviour of other bidders, with the encouragement to participation of the sealed bid auction.

Comparison of alternative auction formats

- 7.12 Ofcom has considered the suitability of alternative auction formats to this particular band of spectrum, taking account of the following factors:
- simplicity, speed and costs of administration and participation;
 - incentives for participation;
 - efficiency of outcome; and
 - opportunities for collusion.

Simplicity, speed and costs of administration and participation

- 7.13 Single-round, sealed-bid auctions are particularly simple, quick and cheap to both administer and participate in: complex software and systems are not required for the submission and processing of bids; the duration of the auction is predictable and short; and there is no requirement for bidders to attend at a particular location, other than to submit their bids. Although in this case, a multi-round, open, ascending bid auction might also be simple to implement and participate in, it would be somewhat more complex, time consuming and costly than a sealed bid process. Differences in cost and complexity to bidders could have implications for the incentive to participate

in the auction (discussed below). Further, it is not clear that there is significant common value uncertainty with regard to this Spectrum Band that might need to be reduced through a multi-round open process. Ofcom seeks to be a cost-effective regulator, and therefore has a preference for a simple, quick and cheap process over a more complex, longer or expensive process, all other things being equal.

Incentives for participation

7.14 The simplicity, speed and low cost of participation in a single-round sealed bid auction are features that are likely to encourage participation by all interested parties. Even small increases in complexity, time and costs of participation in a multi-round, open, ascending bid auction may discourage participation by less well resourced bidders. Such bidders may, nonetheless, have the best business case for achieving maximum value from the spectrum. Enabling such less well resourced bidders to participate in the auction is therefore important. In the case of the 872-876 MHz paired with 917-921MHz band, incentivising participation may be particularly important because of the uncertainty of demand.

Efficiency of outcome

- 7.15 Leaving aside the participation aspects, there are two factors that might make for an inefficient auction outcome:
- misjudgement by bidders of the bidding behaviour of other bidders (to the extent that the auction format makes such considerations relevant to the bidding strategy adopted); and
 - misjudgement by bidders of the value of the good being sold, including where some part of that value is uncertain and common across bidders.
- 7.16 The extent to which the behaviour of other bidders must be anticipated when deciding how to bid depends on the pricing rule used. For example, in a single-round sealed-bid first price auction, bidders are highly likely to consider how others might bid. When determining what to bid, bidders will typically trade off the amount paid in the event of winning (which they would want to minimise) with the chance of having a higher bid than those of their rivals. In having these considerations, bidders will decide what share of their valuation they will bid. In contrast, in a second price auction, since the winning bidder only pays the bid of the highest loser, each bidder is incentivised to bid up to his true valuation.
- 7.17 In the case of first-price sealed-bid auctions, perceptions of the strength of other bidders can affect the outcome. When a single licence is offered, bidders that under-bid their best estimate of the value of the good, in an attempt to minimise the amount that they will have to pay, may inefficiently lose the auction to a bidder having a lower valuation (but who bids a higher proportion of their value). Differences in perceptions of bidder strength could arise either because there are genuine differences or because one bidder errs in its assessment of the strength of its rivals. Assuming rational behaviours, this problem will not arise with second price auctions because bidders do not have incentives to 'shade' their bids in this way.
- 7.18 However the consultants were of the view that consideration of asymmetries between potential bidders could point to a first-price sealed-bid auction in a particular case if it was perceived that under a second price pricing rule, weaker bidders may be discouraged from participating in the auction. Ofcom has considered the case of stronger bidders participating in the auction and the possibility that this introduces asymmetry. Ofcom is of the view that, given the technical constraints imposed upon

the Spectrum Bands and the resultant low risk of causing interference, there is unlikely to be any incentive for adjacent users to bid for the spectrum, for the purpose of protecting themselves from interference. Even if they did do so, Ofcom would expect them not bid above their least cost alternative for protection from interference and Ofcom considers that this should be particularly low (given its technical proposals for the Spectrum Bands).

- 7.19 In this case, the choice between a first price or a second price rule is based on the considerations towards encouraging entry into the auction on the one hand (first price), and reducing the impact of potential asymmetries between bidders on the other (second-price). While encouraging entry is a desirable objective, Ofcom is of the view that in the Spectrum Bands, the technical constraints are more likely than the pricing rule to influence the level of demand. Given these considerations, Ofcom believes that a second price pricing rule is preferable as it can lead to a more efficient outcome.
- 7.20 When there is common value uncertainty, auction efficiency can be improved by giving bidders the opportunity to respond to information revealed by other bidders (i.e. their bids will reveal some information about their expected valuations). This can be achieved through a multiple round ascending auction. However, as noted above, in this case it is unclear that there is any significant common value uncertainty, (There would be common value uncertainty if there were a significant number of bidders seeking to use the spectrum for the same or similar downstream service based on similar means.) As a result it does not appear that there is a compelling case for incurring additional costs and complexity of a multiple round ascending auction.

Opportunities for collusion

- 7.21 The opportunities for signalling and tacit collusion in the context of a single-round sealed-bid auction are very limited. Tacit collusion is hard to enforce, as parties to the collusive agreement cannot punish those that deviate from the agreement by responding with higher bids in later rounds of bidding (since there is only one round of bidding). By contrast, multi-round open auctions present greater opportunities for these types of behaviour, although good auction design can to some extent reduce these opportunities.
- 7.22 Ofcom intends to prevent parties who collude or attempt to distort the outcome of the award process from winning the licence for the Spectrum Bands.

Conclusion

- 7.23 Ofcom has stated that it intends to select a design for each auction that best fits the circumstances of each award. In the case of the Spectrum Bands, Ofcom proposes at this stage to use a single-round, sealed-bid, second-price auction. This design is simple, quick and low cost to administer and participate in. The risks of an inefficient outcome as a result of using a single-round sealed-bid process are considered to be low in the circumstances of this particular award. The risk of collusion is considered to be low, as opportunities are limited in a single-round sealed-bid process for a single licence.

Rules and procedures for an auction

- 7.24 The following describes Ofcom's proposals for how an auction might be run on the basis that it would be a single-round sealed-bid second-price auction. Full details of

the rules for the action will be included in Regulations that Ofcom will separately publish for consultation and make before the auction.

Application

- 7.25 Bidders will also be required to submit a limited amount of information in support of their application, and to provide an initial deposit with their applications.

Qualification

- 7.26 Ofcom does not intend to restrict who may bid in the auction beyond requiring that each bidder be capable of meeting the terms of the licence to be issued, be a fit and proper person to hold the licence and has not engaged in such actions as collusive behaviour and attempts to distort the outcome of the award.

Bidder association

- 7.27 Two bidders A and B are said to be associated if A has got some level of control over the conduct of the business of B, typically through a share holding, and this will generally give A scope for receiving commercially sensitive information relating to the conduct of B's business. The control may be 'positive' if A can play a role in making some of B's business decisions or it may be 'negative' if the consent of A is required for some of B's business decisions. Bidder association can be the object of specific rules in auction design, for example when several lots are being offered and the promotion of competition warrants a minimum number of non-associated parties within the winning bidders.
- 7.28 Given the design of the auction being proposed, and the fact that only one licence is to be awarded, Ofcom does not consider it necessary to preclude associated organisations from bidding in the auction.

Transparency

- 7.29 Given the auction design being proposed (single-round, sealed-bid, second-price auction) and the absence of rules on association between bidders, Ofcom does not consider it necessary to publish, or distribute to bidders, a list of registered bidders before the end of the award. Bidders should not need to know who they are competing against in order to bid appropriately in an auction of this type.
- 7.30 In the interests of transparency more generally however, Ofcom proposes to publish full details of the bidders' identities, bids received and the licence fee paid after the auction has been completed (once the licence has been issued).

Rules prohibiting collusion

- 7.31 Whilst the proposed auction design presents little opportunity for collusion during the auction itself, Ofcom still intends to make auction rules that expressly prohibit collusion between bidders. These rules will be in addition to general competition law prohibitions on collusion.

Unsold licence

- 7.32 If the licence remains unsold at the end of the auction, either through an absence of bids or default, Ofcom will reconsider its approach to release of the spectrum, and will choose whatever course of action it considers appropriate at that time.

Minimum price

- 7.33 Ofcom proposes that the level of the reserve price be set at £50,000, which will be the minimum for any valid bid. Ofcom's primary objective in the auction is to promote the optimal use of the spectrum. Ofcom considers that the main function of the reserve price in this award is to deter frivolous bidders and it should be set at the minimum level necessary to do this without deterring genuine bidders.

Deposits

- 7.34 Deposits are upfront payments that will be forfeited if a bidder breaks specific auction rules or a winning bidder defaults on its payment. They help to deter frivolous bidders and to reduce any strategic incentives for default. An initial deposit of 50% of the reserve price will be required at the time each bidder applies to take part in the auction. Bidders will also be required to submit deposits at the same time as their bids: Ofcom proposes to set the level of the deposit at 50% of the amount bid by each bidder. Setting a deposit based on the proportion of the amount bid will ensure that the deposit is sufficiently high to deter strategic default. If a bidder does not provide a deposit by the relevant deadline, it will not be considered to have submitted a valid bid and will not be considered further in the award process.
- 7.35 Deposits will be required by electronic transfer.
- 7.36 Deposits will be returned to non-winning bidders at the end of the auction (minus any penalties that might have been incurred). Ofcom does not plan to include interest on deposits it will refund, as it expects that the period for which it will hold deposits to be relatively short.

Payment terms and default on payment

- 7.37 Ofcom proposes that the winning bidder should be required to pay 100% of the fee for their licence by a specified time and the licence will only be issued after payment has been received. This will encourage bidders to consider their bids and the corresponding business plans carefully and will discourage default on the licence fee. If a bidder defaults on payment for the licence it will forfeit its deposit and may remain liable for the outstanding balance, and of course it will not be granted a licence.
- 7.38 If default does occur then the licence will likely be offered to unsuccessful bidders in rank order of their bids. However, if no bidder takes up the option, the licence will be unsold and Ofcom reserves the right to decide what to do in such a situation.

Penalties

- 7.39 A bidder's deposit may be forfeit in full or in part if it breaches any of the auction rules set out in Regulations, which will cover such actions as the submission of false or misleading information and collusive behaviour. A bidder may also be excluded from the auction. As deposits are to be made by cash electronic transfers, any monetary penalties incurred will be deducted from a bidder's deposit before it is either refunded or set off against payment of a winning bidder's licence fee.

Tied bids

- 7.40 Bids will be made in denominations of £1 in order to minimise the possibility of tied bids (bidders will be encouraged not to bid in round figures). In the event that there are identical highest bids, the relevant bidders will be invited to each submit a further

sealed bid at or above their original bid. In the event of a further tie the winner will be chosen on the basis of a method of random selection from amongst those tied with the highest bid.

Demand uncertainty and award process

- 7.41 The consultants suggested that, given the uncertainty over demand for the Spectrum Bands, Ofcom might undertake a formal demand evaluation stage prior to making a decision on the design of the assignment mechanism. Ofcom has considered the possibility of making the award conditional on evidence of demand as well as the possibility of moving directly to an auction to award the licence.
- 7.42 In summary, Ofcom believes that the advantages of the demand assessment period are unlikely to exceed the disadvantages, given that Ofcom first published proposals for this award in January 2005 in the SFR:IP. The advantages could include an increased period of time to consider potential uses. However this creates some risks related to the uncertainty of the timing of the award and a risk that use of available spectrum may be unnecessarily delayed. Ofcom also considers that the costs for Ofcom of these two options are very similar although they could be higher with a demand assessment period.
- 7.43 On balance, Ofcom believes that it should proceed by moving the proposed auction within the framework of a due process.

Section 8

Next steps and timetable

Analysis of responses

- 8.1 Ofcom will analyse all responses it receives by the closing date for this consultation of 21 June 2006 and consider them against its statutory duties in finalising the award process.

Publication of an Information Memorandum and award regulations

- 8.2 Ofcom will publish an Information Memorandum for the award. This will be designed to give bidders as much information as possible for them to decide whether to enter the auction and how they would prepare for participation. It may be modified or complemented by the publication of updates and answers to specific questions.
- 8.3 Regulations will provide the legal basis for the auction and contain detailed rules and procedures for its running. The regulations are made by means of a statutory instrument. Ofcom will publish them in draft, with a minimum of 28 days allowed for comments. When all comments have been considered and necessary amendments made, Ofcom will make the Regulations and submit them for registration and publication. They will come into force after a minimum of 21 days following their making.
- 8.4 According to Ofcom's provisional timetable, both the Information Memorandum and the draft regulations should be published at the same time by the end of 2006. The final version of the regulations would then be made to allow the auction to take place in early 2007.

Other regulations and documents for publication

- 8.5 As part of the preparations for this award and before prospective bidders are invited to consider participating in the award process, Ofcom will publish new regulatory documents and amend existing regulations to incorporate the conclusions of this consultation where appropriate.
- 8.6 This will include:
- amending the spectrum trading regulations (Statutory Instrument 2004 No. 3154) before the award process to cover the Spectrum Bands;
 - publishing an interface requirement for the band before the award process to reflect the technical conditions to be adopted for the licences;
 - preparing an order limiting the number of licences in the Spectrum Bands;
 - amending the UK Frequency Allocation Table at the next relevant regular update and UK Frequency Allocation Plan after the award to include the new assignment for the Spectrum Bands.

Events and communications on the award

- 8.7 Ofcom intends to organise a seminar on the proposals in this document during the consultation period.
- 8.8 There are likely to be further events to assist potential bidders in understanding the auction rules before the auction takes place.

Annex 1

Responding to this consultation

How to respond

Ofcom invites written views and comments on the issues raised in this document, to be made by **5pm on 21 June 2006**.

Ofcom strongly prefers to receive responses as e-mail attachments, in Microsoft Word format, as this helps us to process the responses quickly and efficiently. We would also be grateful if you could assist us by completing a response cover sheet (see Annex 2), among other things to indicate whether or not there are confidentiality issues. The cover sheet can be downloaded from the 'Consultations' section of our website.

Please can you send your response to first joe.sonke@ofcom.org.uk.

Responses may alternatively be posted or faxed to the address below, marked with the title of the consultation.

Joe Sonke

Floor 3
Spectrum Policy Group
Riverside House
2A Southwark Bridge Road
London SE1 9HA

Fax:020 7783 4303

Note that we do not need a hard copy in addition to an electronic version. Also note that Ofcom will not routinely acknowledge receipt of responses.

It would be helpful if your response could include direct answers to the question asked in this document, which is included at Annex 4. It would also help if you can explain why you hold your views, and how Ofcom's proposals would impact on you.

Further information

If you have any want to discuss the issues and questions raised in this consultation, or need advice on the appropriate form of response, please contact on Joe Sonke on 020 7783 4345.

Confidentiality

Ofcom thinks it is important for everyone interested in an issue to see the views expressed by consultation respondents. We will therefore usually publish all responses on our website, www.ofcom.org.uk, ideally on receipt (when respondents confirm on their response cover sheet that this is acceptable).

All comments will be treated as non-confidential unless respondents specify that part or all of the response is confidential and should not be disclosed. Please place any confidential parts of a response in a separate annex, so that non-confidential parts may be published along with the respondent's identity.

Ofcom reserves its power to disclose any information it receives where this is required to carry out its legal requirements. Ofcom will exercise due regard to the confidentiality of information supplied.

Please also note that copyright and all other intellectual property in responses will be assumed to be licensed to Ofcom to use, to meet its legal requirements. Ofcom's approach on intellectual property rights is explained further on its website, at www.ofcom.org.uk/about_ofcom/gov_accountability/disclaimer.

Next steps

Following the end of the consultation period, Ofcom intends to publish a statement by the end of 2006.

Please note that you can register to get automatic notifications of when Ofcom documents are published, at http://www.ofcom.org.uk/static/subscribe/select_list.htm.

Ofcom's consultation processes

Ofcom is keen to make responding to consultations easy, and has published some consultation principles (see Annex 2) which it seeks to follow, including on the length of consultations.

If you have any comments or suggestions on how Ofcom conducts its consultations, please call our consultation helpdesk on 020 7981 3003 or e-mail us at consult@ofcom.org.uk. We would particularly welcome thoughts on how Ofcom could more effectively seek the views of those groups or individuals, such as small businesses or particular types of residential consumers, whose views are less likely to be obtained in a formal consultation.

If you would like to discuss these issues, or Ofcom's consultation processes more generally, you can alternatively contact Vicki Nash, Director, Scotland, who is Ofcom's consultation champion:

Vicki Nash
Ofcom
Sutherland House
149 St Vincent Street
Glasgow
G2 5NW
Tel: 0141 229 7401
Fax: 0141 229 7433
E-mail: vicki.nash@ofcom.org.uk

Annex 2

Ofcom's consultation principles

A2.1 Ofcom has published the following seven principles that it will follow for each public written consultation:

Before the consultation

A2.2 Where possible, we will hold informal talks with people and organisations before announcing a big consultation to find out whether we are thinking in the right direction. If we do not have enough time to do this, we will hold an open meeting to explain our proposals shortly after announcing the consultation.

During the consultation

A2.3 We will be clear about who we are consulting, why, on what questions and for how long.

A2.4 We will make the consultation document as short and simple as possible with a summary of no more than two pages. We will try to make it as easy as possible to give us a written response. If the consultation is complicated, we may provide a shortened version for smaller organisations or individuals who would otherwise not be able to spare the time to share their views.

A2.5 We will normally allow ten weeks for responses to consultations on issues of general interest.

A2.6 There will be a person within Ofcom who will be in charge of making sure we follow our own guidelines and reach out to the largest number of people and organisations interested in the outcome of our decisions. This individual (who we call the consultation champion) will also be the main person to contact with views on the way we run our consultations.

A2.7 If we are not able to follow one of these principles, we will explain why. This may be because a particular issue is urgent. If we need to reduce the amount of time we have set aside for a consultation, we will let those concerned know beforehand that this is a 'red flag consultation' which needs their urgent attention.

After the consultation

A2.8 We will look at each response carefully and with an open mind. We will give reasons for our decisions and will give an account of how the views of those concerned helped shape those decisions.

Annex 3

Consultation response cover sheet

- A3.1 In the interests of transparency, we will publish all consultation responses in full on our website, www.ofcom.org.uk, unless a respondent specifies that all or part of their response is confidential. We will also refer to the contents of a response when explaining our decision, without disclosing the specific information that you wish to remain confidential.
- A3.2 We have produced a cover sheet for responses (see below) and would be very grateful if you could send one with your response. This will speed up our processing of responses, and help to maintain confidentiality by allowing you to state very clearly what you don't want to be published. We will keep your completed cover sheets confidential.
- A3.3 The quality of consultation can be enhanced by publishing responses before the consultation period closes. In particular, this can help those individuals and organisations with limited resources or familiarity with the issues to respond in a more informed way. Therefore Ofcom would encourage respondents to complete their cover sheet in a way that allows Ofcom to publish their responses upon receipt, rather than waiting until the consultation period has ended.
- A3.4 We strongly prefer to receive responses in the form of a Microsoft Word attachment to an email. Our website therefore includes an electronic copy of this cover sheet, which you can download from the 'Consultations' section of our website.
- A3.5 Please put any confidential parts of your response in a separate annex to your response, so that they are clearly identified. This can include information such as your personal background and experience. If you want your name, address, other contact details, or job title to remain confidential, please provide them in your cover sheet only so that we don't have to edit your response.

Cover sheet for response to an Ofcom consultation

BASIC DETAILS

Consultation title: Award of available spectrum: 872-876 MHz paired with 917-921 MHz

To (Ofcom contact): Joe Sonke

Name of respondent:

Representing (self or organisation/s):

Address (if not received by email):

CONFIDENTIALITY

What do you want Ofcom to keep confidential?

Nothing Name/contact details/job title

Whole response Organisation

Part of the response If there is no separate annex, which parts?

If you want part of your response, your name or your organisation to be confidential, can Ofcom still publish a reference to the contents of your response (including, for any confidential parts, a general summary that does not disclose the specific information or enable you to be identified)?

DECLARATION

I confirm that the correspondence supplied with this cover sheet is a formal consultation response. It can be published in full on Ofcom's website, unless otherwise specified on this cover sheet, and I authorise Ofcom to make use of the information in this response to meet its legal requirements. If I have sent my response by email, Ofcom can disregard any standard e-mail text about not disclosing email contents and attachments.

Ofcom seeks to publish responses on receipt. If your response is non-confidential (in whole or in part), and you would prefer us to publish your response only once the consultation has ended, please tick here.

Name

Signed (if hard copy)

Annex 4

Consultation question

Question: Do stakeholders agree with these proposals for the award of this band or have any other comments on the contents of this document?

Annex 5

Draft Licence

A5.1 Please note that the following draft licence represents Ofcom's current thinking and may well change as it develops and after consideration of responses to this consultation.

Wireless Telegraphy Acts 1949 and 1998
Office of Communications (Ofcom)

**SPECTRUM ACCESS LICENCE FOR THE USE OF THE SPECTRUM
BANDS 872.0 – 876.0 MHz PAIRED WITH 917.0 – 921.0 MHz**

Licence no. **[Insert Licence Number]**

Date of first issue: **[Insert Date of First Issue]**

1. The Office of Communications (Ofcom) grants this licence to

[Insert Licensee's Name and Company Registration Number (if a company)]

("the Licensee")

[Insert Registered Company Address]

XXXXXXXXXXXX

XXXXXXXXXXXX

XXXXXXXXXXXX

XXXXXXX

to establish, install and use radio transmitting and receiving stations and/or radio apparatus as described in the schedule(s) (herein after together called "the Radio Equipment") subject to the terms set out below.

Licence Term

2. This Licence shall continue in force until revoked by Ofcom in accordance with paragraph 3 below or surrendered by the Licensee.

DRAFT – Subject to consultation

Licence Revocation and Variation

3. Pursuant to section 4 of the Wireless Telegraphy Act 1998 (the “1998 Act”) Ofcom may not revoke or vary this Licence under section 1(4) of the Wireless Telegraphy Act 1949 except:
- (a) at the request, or with the consent, of the Licensee;
 - (b) in accordance with paragraphs 8 and 9;
 - (c) if there has been a breach of any of the terms of the Licence;
 - (d) if, in connection with the transfer or proposed transfer of rights and obligations arising by virtue of the Licence, there has been a breach of any provision of regulations made by Ofcom under the powers conferred by section 168(1) and (3) of the Communications Act 2003¹;
 - (e) if, in relation to the Licensee, any of the events listed in regulation [XX] of the [Award Regulations] occurred prior to the grant of this Licence where the occurrence of the event materially affected the outcome of the award process under these regulations;
 - (f) in accordance with section 4(5) of the Wireless Telegraphy Act 1998;
 - (g) if it appears to Ofcom to be necessary or expedient to revoke the Licence for the purposes of complying with a direction by the Secretary of State given to Ofcom under section 5 or section 156 of the Communications Act 2003; or
 - (h) for reasons related to the management of the radio spectrum, provided that in such case:
 - (i) this power to revoke may only be exercised after at least five (5) year’s notice is given in writing to the Licensee; and
 - (ii) such notice must expire after fifteen (15) years from the date of first issue of this Licence.
4. Ofcom may only revoke or vary this Licence by notification in writing to the Licensee and in accordance with section 1E of the Wireless Telegraphy Act 1949.

Changes

5. This Licence may not be transferred. The transfer of the rights and obligations arising by virtue of this Licence may be authorised in accordance with regulations made by Ofcom under powers conferred by section 168(1) and (3) of the Communications Act 2003.

¹ These are regulations on spectrum trading.

DRAFT – Subject to consultation

6. The Licensee must give prior notice to Ofcom in writing of any proposed change to the Licensee's name and address from that recorded on the Licence.

Fees

7. The Licensee shall pay to Ofcom the fee(s), in cash and without set-off or counter-claim, described in Schedule 2 of this Licence, on the date(s) also described therein, failing which Ofcom may revoke this Licence. In accordance with section 4A of the Wireless Telegraphy Act 1998 any such fee is recoverable by Ofcom.
8. On or after the expiry of fifteen years from the date of issue of this Licence the Licensee shall pay to Ofcom such sum(s) as may be provided for in regulations made by Ofcom under section 1 and 2(2) of the Wireless Telegraphy Act 1998, failing which Ofcom may revoke this Licence.
9. The Licensee shall also pay interest to Ofcom on any amount which is due under the terms of this Licence or provided for in any regulations made by Ofcom under section 1 and 2(2) of the Wireless Telegraphy Act 1998 from the date such amount falls due until the date of payment, calculated with reference to the Bank of England base rate from time to time. In accordance with section 4A of the Wireless Telegraphy Act 1998 any such amount and any such interest is recoverable by Ofcom.
10. If the Licence is surrendered or revoked, no refund, whether in whole or in part of any amount which is due under the terms of this Licence or provided for in any regulations made by Ofcom under section 1 and 2(2) of the Wireless Telegraphy Act 1998 will be made, except at the absolute discretion of Ofcom in accordance with regulation [XX] of the [Award Regulations].

Radio Equipment Use

11. The Licensee must ensure that the Radio Equipment is constructed, established, installed and used only in accordance with the provisions specified in Schedule 1 of this Licence. Any proposal to amend any detail specified in Schedule 1 of this Licence must be agreed with Ofcom in advance and implemented only after this Licence has been varied or reissued accordingly.
12. The Licensee must ensure that the Radio Equipment is operated in compliance with the terms of this Licence and is used only by persons who have been authorised in writing by the Licensee to do so and that such persons are made aware of, and of the requirement to comply with, the terms of this Licence.

Access and Inspection

13. The Licensee shall permit any person authorised by Ofcom:
- (a) to have access to the Radio Equipment; and
 - (b) to inspect this Licence and to inspect, examine and test the Radio Equipment,

at any and all reasonable times or, when in the opinion of that person an urgent situation exists, at any time to ensure the Radio Equipment is being used in accordance with the terms of this Licence.

Modification, Restriction and Closedown

14. A person authorised by Ofcom may require the Radio Equipment, or any part thereof, to be modified or restricted in use, or temporarily or permanently closed down immediately if in the opinion of the person authorised by Ofcom:

- (a) a breach of this Licence has occurred; and/or
- (b) the use of the Radio Equipment is causing or contributing to undue interference to the use of other authorised radio equipment.

15. Ofcom may require the Radio Equipment to be modified or restricted in use, or temporarily or permanently closed down either immediately or on the expiry of such period as may be specified in the event of a national or local state of emergency being declared. Ofcom may only exercise this power after a written notice is served on the Licensee or a general notice applicable to holders of a named class of Licence is published.

Geographical Boundaries

16. This Licence authorises the Licensee to establish, install and use the Radio Equipment only in the United Kingdom.
17. This Licence does not authorise the establishment and use of the Radio Equipment in the Isle of Man or in the Channel Islands.

Interpretation

- 18.** In this Licence-
- (a) the establishment, installation and use of the Radio Equipment shall be interpreted as establishment and use of stations and installation and use of apparatus for wireless telegraphy as specified in section 1 of the Wireless Telegraphy Act 1949; and
 - (b) the expressions "undue interference", "station for wireless telegraphy" and "apparatus for wireless telegraphy" shall be construed in accordance with section 19 of the Wireless Telegraphy Act 1949.
- 19.** The schedules to this Licence form part of this Licence together with any subsequent schedules which Ofcom may issue as a variation to this Licence at a later date.
- 20.** The Interpretation Act 1978 shall apply to this Licence as it applies to an Act of Parliament.

Issued by Ofcom

Signed by

For the Office of Communications

SCHEDULE 1 TO LICENCE NUMBER: **[Insert Licence Number]**

Licence Category: **Spectrum Access Licence for the use of the Spectrum Bands 872 – 876 MHz paired with 917 – 921 MHz**

This schedule forms part of licence no **[Insert Licence Number]**, issued to **[Insert Licensee's name]**, on **[Insert Date]**.

1. Description of Radio Equipment Licensed

In this Licence, the Radio Equipment means any station for wireless telegraphy or apparatus for wireless telegraphy.

2. Interface Requirements for the Radio Equipment

That Radio Equipment shall comply with one or other of the following Interface Requirement:

IR [XXX] [Spectrum Access Systems – 872-876 MHz and 917-921 MHz]
[This Interface Requirement will be made available by Ofcom on its website when finalised, consistent with the relevant process of submission in draft to the European Commission for comments.]

3. Special Conditions relating to the Operation of the Radio Equipment

(a) During the period that this Licence remains in force and for 6 months thereafter, unless consent has otherwise been given by Ofcom, the Licensee shall compile and maintain accurate written records of:

(i) the following details relating to the Radio Equipment:

- a) postal address;
- b) National Grid Reference (to 100 Metres resolution);
- c) antenna height (above ground level) and type;
- d) radio frequencies used by the Radio Equipment;

- (ii) a statement of the number of subscribing customers.

- (b) The Licensee shall inform Ofcom of the address of the premises at which this Licence and the information detailed at sub-paragraph (a) above shall be kept.

- (c) The Licensee must submit to Ofcom copies of the records detailed in sub-paragraph (a) above at such intervals as Ofcom shall notify to the Licensee.

- (d) The Licensee must also submit to Ofcom in such a manner and at such times, all information relating to the establishment, installation or use of the station for wireless telegraphy or apparatus for wireless telegraphy, whether stored in hard copy or electronic form, as reasonably requested for the purposes of verifying compliance with this Licence or for statistical purposes.

4. Site Clearance Requirements

- (a) Except where specified in sub-paragraph 4(b), the Licensee must obtain from Ofcom a valid site clearance certificate prior to establishing, installing or using the Radio Equipment:

- (b) Sub-paragraph 4(a) does not apply to:
 - (i) base transceiver stations incorporating transmitters radiating not more than 17dBW ERP; or

 - (ii) aerial systems, which do not extend beyond thirty (30) metres above ground level, or which do not increase the height of an existing building by more than five (5) metres (whichever is the higher).

5. Cross-border Co-ordination

The Radio Equipment shall be operated in compliance with such cross-border co-ordination and sharing procedures as may be notified to the Licensee by Ofcom.

DRAFT – Subject to consultation

6. Permitted Frequency Bands

Subject to the Out-of-Block Emissions permitted under paragraph 8, the Radio Equipment must only transmit and/or receive on the following two frequency bands (the “Permitted Frequency Bands”):

- (a) 872.0 – 876.0 MHz – Mobile Transmit; and
- (b) 917.0 – 921.0 MHz – Base Transmit.

The band 872.0 to 876.0 MHz shall be used for transmission by mobile user stations; use of static transmitters in this band is not authorised under this Licence.

7. Permissible Out-of-Block Emissions

For out-of-block emissions, the Maximum Mean EIRP, within the frequency ranges set out below outside of either of the Permitted Frequency Bands of Operation, shall not exceed the following.

Out-of-block emissions are specified as the maximum mean EIRP and are directly applicable to a transmission site at its specific location. Any use of multiple transmitters or antennas at a transmission site is required to comply with the EIRP limit for the site so that the combined EIRP of multiple transmitters and antennas does not exceed the EIRP limits defined below.

DRAFT – Subject to consultation

Below the permitted frequency band 872.0 to 876.0 MHz	
Frequency of measurement	Maximum mean EIRP in dBm/100 kHz
Below 870.0 MHz	-36

Above the permitted frequency band 872.0 to 876.0 MHz	
Frequency of measurement	Maximum mean EIRP per mobile station in dBm
876.0 MHz	-9
876.1 to 877.5 MHz	-27
877.5 to 878.7 MHz	-35
878.7 to 881.7 MHz	-37
Above 881.7 MHz	-43

Below the permitted frequency band 917.0 to 921.0 MHz	
Frequency of measurement	Maximum mean EIRP in dBm/200 kHz
916.9 MHz	2
915.0 to 916.7 MHz	-28
Below 915.0 MHz	-81

Above the permitted frequency band 917.0 to 921.0 MHz	
Frequency of measurement	Maximum mean EIRP per transmission site in dBm
921.0 MHz	14
921.1 MHz	-4
921.1 to 921.9 MHz	-13
921.9 to 922.5 MHz	-16
922.5 to 926.7 MHz	-23
Above 926.7 MHz	-29

DRAFT – Subject to consultation

8 Spurious Emissions

Outside the Permitted Frequency Bands, the out-of-block spurious emissions shall not exceed a maximum mean EIRP density of -36 dBm/100 kHz.

9. Maximum Mean EIRP and Maximum Mean EIRP Density for the Permitted Frequency Bands

- (a) The frequencies 875.8 MHz to 876.0 MHz and 920.8 MHz to 921 MHz shall not form part of the occupied bandwidth of the transmission.
- (b) The Maximum mean EIRP in the Permitted Frequency Bands shall not be greater than the figures indicated in the following tables.

For the frequency band 872.0 to 876.0 MHz	
Across the 3.8 MHz of the permitted frequencies for the occupied bandwidth of the transmission	Maximum mean EIRP in dBm per mobile station within the licensed band
872.0 to 875.8 MHz	33

For the frequency band 917.0 to 921.0 MHz	
Across the 3.8 MHz of the permitted frequencies for the occupied bandwidth of the transmission	Maximum mean EIRP in dBm per transmission site within the licensed band
917.0 to 920.8 MHz	32 + 10 x GB*, limited to a maximum of 56 dBm

* Note: GB is the continuous frequency range, measured in MHz, from the frequency 917.0 MHz, which does not form part of the occupied bandwidth of the transmission. If GB is greater than 2.4 MHz, the maximum value of 56 dBm EIRP per transmission site applies.

10. Location of transmitters relative to certain railway tracks and installation relative to other base stations

Any base station operating in the Permitted Frequency Band 917.0 MHz to 921.0 MHz shall be located in such a way that there remains a minimum separation distance from the edge of any railway track which is within the scope of use of transmitters operating under a wireless telegraphy licence for

DRAFT – Subject to consultation

GSM-R operations at the frequencies 921.0 MHz to 925.0 MHz. The relevant separation distances are:

- (a) 75 metres if the base station is operating in such a way that the EIRP for its transmission site is no greater than 32 dBm;
- (b) 250 metres if the base station is operating in such a way that the EIRP for its transmission site exceeds 32 dBm.

[Ofcom is considering further provisions on reduced distances in specific cases in case of agreement between the Licensee and the holder of the licence for GSM-R operations at 921-925 MHz.]

Any base station operating in the Permitted Frequency Band 917.0 MHz to 921.0 MHz shall be located in such a way that there remains a minimum separation distance of 520 metres from any base station not equipped with a duplexor and operating under a wireless telegraphy licence for GSM operations at the frequencies 910.0 MHz to 915.0 MHz.

[Ofcom is considering further provisions on reduced distances in specific cases in case of agreement between the Licensee and the holder of the licence for GSM operations at 910-915 MHz.]

11. Interpretation

In this Schedule:

- a) “Mobile Transmit” means transmission from any mobile or user station;
- b) “Base Transmit” means transmission from any base station;
- c) “EIRP” means the effective isotropically radiated power. This is the product of the power supplied to the antenna and the antenna gain in a given direction relative to an isotropic antenna (absolute or isotropic gain);
- d) “ERP” means the effective radiated power. This is the product of the power supplied to the antenna and its gain relative to a half-wave dipole;
- e) “dBm” means the power level in decibels (logarithmic scale) referenced against 1 milliWatt (i.e. a value of 0 dBm is 1 mW);

DRAFT – Subject to consultation

- f) “dBW” means the power level in decibels (logarithmic scale) referenced against 1 Watt (i.e. a value of 0 dBW is 1 W);

- g) “Occupied bandwidth” means the width of the frequency band occupied such that, below the lower and above the upper frequency limits, the mean powers emitted are each equal to 0.5% of the total mean power of the emission;

- h) “Maximum mean EIRP density” means the average EIRP transmitted during an interval of time sufficiently long compared with the lowest frequency encountered in the modulation taken under normal operating conditions;

- i) “Maximum mean EIRP” means, over a frequency range, the average EIRP transmitted during an interval of time sufficiently long compared with the lowest frequency encountered in the modulation taken under normal operating conditions over the specified frequency range;

- j) “Out-of-Block Emissions” means radio frequency emissions generated by the Radio Equipment and radiated into the frequency bands adjacent (in terms of frequency) to the Licensee’s Permitted Frequency Bands;

- k) “Permitted Frequency Bands” means the two frequency bands set out in paragraph 6 in which wireless telegraphy is authorised under this Licence.

- l) “Transmission site” means any location where one or more transmitters operating in the band 917.0 to 921 MHz using the same antenna or the same mast are established or installed or any location where several transmitters operating in the band 917.0 to 921 MHz using different antennas or different masts are established or installed within 20 metres of each other.

- m) “Duplexor” means device which allows a transmitter operating on one frequency and a receiver operating on a different frequency to share one common antenna with limited interaction and degradation of the radio signals.

[Insert Company Name]
Spectrum Access Licence for the use of the Spectrum Bands
872 – 876 MHz paired with 917 – 921 MHz
Company Registration no. [Insert number]
First Issued: [Insert First Issue Date] - Licence Number: [Insert Licence Number] – Issue 1 - dd/mm/yy
DRAFT – Subject to consultation

SCHEDULE 2 TO LICENCE NUMBER: **[Insert Licence Number]**

Licence Category: **Spectrum Access Licence for use of the Spectrum Bands 872 – 876 MHz paired with 917 – 921 MHz**

[Licence fees – date of payment and amount of fee]

Annex 6

Impact assessment

Introduction

- A6.1 Ofcom is proposing to award rights to use the 872-876 MHz/915-917 MHz band by auction in early 2007. It is proposed that that award will be of a single national licence and will be technology neutral. Ofcom is also proposing that the auction will take the format of a second price sealed bid auction.
- A6.2 In the Spectrum Framework Review: Implementation Plan (SFR:IP) Ofcom set out two options for the award of the spectrum bands 872-876 MHz paired with 917-921 MHz band. These options were:
- award regional licences;
 - award a single UK licence.
- A6.3 Ofcom proposed to auction one UK licence that would be technology neutral, tradable and transferable as this would be the most efficient use of the spectrum and would avoid the licence being constrained by any co-ordination requirements between different licensees which would be necessary in the case of regional licences. However, given the potential range of uses of this spectrum and the technologies that might be deployed, Ofcom considered that a preliminary study of the uses would be required to determine the most appropriate approach to awarding this spectrum.
- A6.4 Ofcom commissioned a market study from DotEcon and Analysys and Mason Communications to inform its assessment of these different options. This study assessed the different technologies and services which could be offered in the Spectrum Bands and made recommendations as to the appropriate spectrum packaging, licence conditions and award process.
- A6.5 Following the SFR:IP consultation, Ofcom published a further document on technical constraints for use of the 917-921 MHz band (the February note) to take into account the desirability of avoiding interference to adjacent networks. This document was published with a view to assisting potential respondents to the SFR:IP consultation and set out in particular that in order to reduce blocking to GSM (O2) receiver stations below 915 MHz, the transmitted power in the band 917-921 MHz would be restricted to a level not exceeding 32dBm.
- A6.6 This Annex takes into consideration the outcome of the market study and the responses to Ofcom's proposals set out in the SFR:IP. It should be considered along with the main body of this document and other annexes; together these form an Impact Assessment in relation to the major regulatory proposals concerning this matter.

Spectrum demand, packaging and award mechanism

- A6.7 The market study completed by DotEcon and Analysys and Mason Communications identified that although CDMA2000 might be a suitable technology, the combination of restrictions (lack of wide area coverage and amount of spectrum accommodating a maximum of two 1.25 MHz channels) meant that wide-area CDA2000 deployment would not be viable. Although the Spectrum Bands could potentially be suitable for

PMR/PAMR use, it may be less attractive to use them due to the lack of available equipment and the higher network deployment costs for wide area coverage. However the Spectrum Bands could potentially be used for PMSE as replacement spectrum for VHF or UHF bands.

- A6.8 Given that demand is uncertain, Ofcom has considered whether the available spectrum should be split between a number of licences and whether regional or national licences should be offered. Ofcom proposes that since there is no obvious basis on which to package the spectrum, a single UK package is more efficient as it avoids the need to manage interference with other licensees. Similarly, given the uncertainty of demand there seems little basis for awarding on a pre-determined geographical basis and a licensee may be better placed to determine if this makes commercial sense by trading in the secondary market.
- A6.9 A significant feature of the award of the Spectrum Bands is the potential to cause undue interference to adjacent GSM users. Ofcom is of the view that optimal use of the spectrum will be achieved by having due regard to the risk that harmful interference would cause to investment for the development of wireless networks and services. Therefore, Ofcom has proposed a specific limit on the maximum power per transmission site, and co-ordination measures to be undertaken with respect to those base stations in the adjacent 910-915MHz band that do not have duplexors fitted.
- A6.10 The consultants' study considered whether an auction was strictly necessary given the uncertainty of demand and discussed a formal demand evaluation stage prior to making a decision on the final design of an assignment mechanism. Ofcom has considered this and proposed that holding a further demand evaluation process is less beneficial than bringing forward proposals for an auction process.
- A6.11 The consultants also considered that given the apparent lack of market interest, there does not need to be any urgency to bring the Spectrum Bands into the market. Ofcom has considered this and has proposed that holding the auction soon after the consultation process would allow interested parties to demonstrate whether or not there is demand for the spectrum.
- A6.12 Concerning the assignment by auction, the consultants proposed that this should take place by means of a sealed bid auction as this format is more robust to a low competition scenario. Given the possibility of bidder asymmetry, a first price sealed bid is likely to be the best format for attracting entry. If there were more than two bidders, the efficiency of a sealed bid could potentially be improved by preceding it with an ascending bid phase. Ofcom has considered the consultants' report and concurs that a sealed bid auction is suitable. It is however of the view that due to the technical constraints attached to the use of the spectrum, it is unlikely that incumbents in adjacent spectrum will need to acquire the licence to ensure protection against harmful interference. As a result, the asymmetry of bidders leading to deterrence of some bidders is a lower concern. In such a situation, it is more efficient to have a second price pricing rule that incentivises bidders to reveal their true valuation.
- A6.13 The benefits, costs and risks of the proposals made by Ofcom are set out below.

Packaging, technical constraints and timing of auction

Option	Benefits	Costs	Risks
Licence exemption with restrictions on use	Suitable where there is little risk of interference and no specific technology likely to be more efficient.	Significant costs in co-ordinating use between licensees may make some business models unviable.	Restrictions on use may deter some users and some technologies and lead to inefficient use of spectrum. Could also effectively sterilise the spectrum for future use by other technologies under a licensing framework.
Regional licences	Appropriate if there is evidence of strong demand for smaller configurations of frequency.	May create aggregation risks for the bidder and require licensees to incur additional co-ordination costs between themselves.	Risk of deterring entry in the award because of the need to impose co-ordination requirements. Splitting into smaller packages might also limit possibilities for future use and aggregation in the secondary market
UK licence	Demand expected to be national. Avoids the need for bidders to co-ordinate pre-auction or winning bidders to co-ordinate post-auction. Still offers scope for flexible partitioning through trading.	Winning bidder will have to bear all potential costs of co-ordination with O2 on its own; if demand turned out to be less than national, Ofcom might incur costs to run another auction.	If demand was not for national licences, risk that licence would remain unsold.
Technical constraints	Ensure that all users are protected from harmful interference and promote the efficient use and management of spectrum; provide potential users with guidance on power limits; avoid potential disputes regarding emission limits.	Potential users will need to incur some additional mitigation cost if they wish to use the spectrum at power greater than 32 dBm; however, this is only for base stations not fitted with duplexors and is therefore likely to be for a relatively smaller number of base stations.	Given context of uncertain demand, technical constraints may make demand even more uncertain; risk that licence might not be awarded to those that can generate highest value from it.

Award of available spectrum: 872-876 MHz paired with 917-921 MHz

Option	Benefits	Costs	Risks
Award conditional on evidence of demand	Avoids cost of running an auction; allows time for new technologies to be brought forth; allows potential participants more time to prepare plans for mitigation in respect of adjacent users if higher powers were to be used.	Some level of uncertainty as to the exact timing of an award. Similar scale of resources might be required to undertake an expression of interest stage. If more than one bidder expresses interest, Ofcom would have to incur further costs to run an auction.	Risk that release of the spectrum to the market might be unduly delayed.
Timing of the auction	Holding an auction now would allow the market to demonstrate level of demand, a feature that Ofcom cannot assess independently. Greater clarity of the award process and timing.	If there is no interest at the time, may result in unnecessary costs of preparing the award.	If new and more value-added technologies are still developing, risk that a premature auction would result in inefficient allocation to a lower value user. However, this is not likely to be significant if the licence can be traded in the secondary market with a higher value purchaser.

Auction format and pricing rules

Option	Benefit	Costs	Risks
Ascending bid auction	Simple to implement and participate in. It can provide benefits if there is common value uncertainty. Attractive to strong bidders, as they pay no more than necessary to win.	A little more complex than a sealed bid. More susceptible to collusion and rules prohibiting collusion need to be devised.	Weaker bidders may be discouraged from participating. Given uncertainty of demand here, may weaken the auction.
Sealed bid with first price	Simple, quick and easy to run. Can attract more entry if bidders are asymmetric.	Strategic bidding results in bidders shading their bids.	Due to strategic bidding, licence may be awarded inefficiently to bidder having low valuation.

Award of available spectrum: 872-876 MHz paired with 917-921 MHz

Option	Benefit	Costs	Risks
Sealed bid auction with second price	Simple, quick and easy to run. Allows bidders to reveal their true valuations. Given technical constraints on spectrum, little reason to believe asymmetry might be introduced by incumbent GSM users entering the auction; if bidders are not asymmetric, can result in more efficient outcome than first price.	May deter weak bidders from participating if there are significant asymmetries between interested parties.	Less attractive to weaker bidders than first price. Licence may be awarded at reserve price if there is no competing demand.

A6.14 The analysis set out above supports Ofcom’s decision to award the spectrum through the auction of single UK licence on a sealed bid second price rule basis.

Annex 7

Transmission rights

- A7.1 The transmission rights for the spectrum are primarily limited by the potential for interference to O2 as a result of blocking of a receiver in the O2 uplink (910-915 MHz) from a base station in the Spectrum Bands (917-921 MHz). For this reason the spectrum is specified with a limit of EIRP per transmission site of up to 32 dBm if the licensee uses the full 3.8 MHz available or up to 56 dBm if the licensee uses some of the frequencies as an internal guard band from 917 MHz. Different separation distances apply depending on whether a transmission site's power is 32 dBm or less or more than 32 dBm. These distances are the required separation between a transmission site and both railway tracks within the potential scope of GSM-R and some potential GSM base stations operating at 910-915 MHz (those without duplexors).
- A7.2 The analysis underlying the proposed rights is based on the relevant ECC Reports 13, 14, 38, 40 and 41²¹.

Out-of-block emissions

- A7.3 There are four adjacencies to the award spectrum - at 917 MHz, 921 MHz, 872 MHz and 876 MHz. These adjacencies involve four third parties: MoD, the GSM-R licensee (Network Rail), a GSM licensee (O2), and short range devices (SRD, use exempt from licensing).
- A7.4 The requirements on use of the Spectrum Bands in respect of MoD use are not considered in this section.

Boundaries to GSM-R

- A7.5 The band 921-925 MHz, the adjacent band above the base transmit band of the Spectrum Bands, is managed by MoD and shared with Network Rail, which operates under a GSM-R licence. Based on the conclusions of ECC Report 38, GSM-R requires a guard band of 200 kHz. The frequencies 920.8 to 921 MHz and 875.8 to 876 MHz will therefore be left free of carriers.

²¹ The reports are available from the European Radiocommunications Office at <http://www.ero.dk/>.
ECC Report 13 (June 2002): Adjacent band compatibility between Short Range Devices and TETRA TAPS mobile services at 870 MHz.
ECC Report 14 (June 2002): Adjacent band compatibility of UIC Direct mode with TETRA Advanced Packet Data Service (TAPS).
ECC Report 38 (February 2004): The Technical Impact of introducing CDMA-PAMR in the 870-876 / 915-921 MHz band on 12.5 kHz UIC DMO & 200 kHz GSM-R radio systems.
ECC Report 40 (February 2004): Adjacent band compatibility between CDMA-PAMR mobile services and Short Range Devices below 870 MHz.
ECC Report 41 (February 2004): Adjacent band compatibility between GSM and CDMA-PAMR at 915 MHz.

Award of available spectrum: 872-876 MHz paired with 917-921 MHz

Above 921 MHz

A7.6 The out-of-block emissions from the Spectrum Bands above 921.0 MHz have been determined on the basis of the highest emissions from the band 917-921 MHz for that adjacency, i.e. assuming that a transmission site operates at 56 dBm EIRP with an internal guard band.

A7.7 EIRP limits in the table below are expressed in dBm per transmission site.

Frequency (MHz)	Maximum EIRP (dBm per site)
921.0	14
921.1	-4
921.1 to 921.9	-13
921.9 to 922.5	-16
922.5 to 926.7	-23
>926.7	-29

Above 876 MHz

A7.8 EIRP limits in the table below are expressed in dBm per mobile device.

Frequency (MHz)	Maximum EIRP (dBm per mobile device)
876.0	-9
876.1 to 877.5	-27
877.5 to 878.7	-35
878.7 to 881.7	-37
> 881.7	-43

Boundary to GSM (O2) – below 917 MHz

A7.9 The requirement below 917.0 MHz is to manage the risk of interference into GSM mobile stations (handsets) receiving at 910-915 MHz. It is assumed that at separation distances of less than 20 metres good site engineering practice will protect the neighbouring base stations, including GSM base stations.

A7.10 Below 915.0 MHz, the out-of-block emissions shall not exceed -81 dBm/200 kHz. This will yield a field strength of -139 dBm/200 kHz at 20 metres or -125 dBm/200 kHz after correction for a 14 dB antenna gain. The limits for that boundary are as follows.

Below the permitted frequency band 917.0 to 921.0 MHz	
Frequency of measurement	Maximum mean EIRP in dBm/200 kHz
916.9 MHz	2
915.0 to 916.7 MHz	-28
Below 915.0 MHz	-81

Boundary to SRD – below 870 MHz

A7.11 The services below 870 MHz are SRDs for which receiver specifications and studies based on receiver specifications are not available at or near the 870 MHz boundary. Interference into the SRD band will therefore be managed using a limit for out-of-block emissions of -36 dBm/100 kHz, which is derived from ECC Report 40.

Spurious emissions

A7.12 Outside the Permitted Frequency Bands, the out-of-block spurious emissions shall not exceed a maximum EIRP density of -36 dBm/100 kHz, in accordance with ERC Recommendation 74-01²².

In-band emissions and maximum powers (EIRP)

917-921 MHz

A7.13 As referred to earlier in respect of the GSM-R adjacency, the frequencies 920.8 to 921.0 MHz will be left free of carriers (they will not form part of the occupied bandwidth of the transmission). This is the normal GSM guard band applied in this spectrum.

A7.14 There will be a first EIRP threshold for any transmission site using the 917-921 MHz band of 32 dBm. This value is based on the method of calculation used in ECC Report 41.

A7.15 Transmission sites operating at EIRPs of 32 dBm or less must be located with a minimum separation distance of 75 metres from railway tracks within the potential scope of the GSM-R system.

A7.16 The first EIRP threshold may be exceeded up to a maximum of 56 dBm per transmission site, under certain conditions. For a site to operate at a power greater than the first EIRP threshold of 32 dBm, all of the following three conditions must be fulfilled.

- Any increase in power per transmission site is conditional to an internal guard-band (continuous frequencies from 917 MHz) such that the increase in EIRP per transmission site may be of up to 10 dB per MHz of internal guard band. For the avoidance of doubt, if the internal guard band is more than 2.4 MHz (917.0 to 919.4 MHz or higher without carriers), the maximum EIRP per transmission site is 56 dBm.
- Transmission sites operating at EIRPs greater than 32 dBm must be located with a minimum separation distance of 520 metres from any GSM base station operating at 910-915 MHz which is not equipped with a duplexer, unless the GSM licensee agrees otherwise. This is such that the power received into a 0 dB gain antenna in the 910-915 MHz band does not exceed -139 dBm. This is based on the analysis in ECC Report 31 and an additional filtering between the receive and transmit bands of 10 dBm/MHz being provided by a duplexer.
- Transmission sites operating at EIRPs greater than 32 dBm must be located with a minimum separation distance of 250 metres from railway tracks within the potential scope of the GSM-R system.

²² ERC Recommendation 74-01: Unwanted emissions in the spurious domain. It is available from <http://www.ero.dk/>.

Award of available spectrum: 872-876 MHz paired with 917-921 MHz

A7.17 These figures are based on the calculations in ECC Report 38 Annex 2 corrected for the proposed emission mask.

A7.18 For transmission sites operating at EIRPs of 32 dBm or less, there are no specific separation distances from GSM base stations operation at 910-915 MHz (with or without duplexors). However, the licensee is required to install and arrange such transmission sites and any other transmitter according to good site engineering practice.

872-876 MHz

A7.19 With respect to the GSM-R adjacency, the frequencies 875.8 to 876.0 MHz will be left free of carriers (they will not form part of the occupied bandwidth of the transmission). This is paired with the guard band at 920.8 to 921.0 MHz.

A7.20 The maximum EIRP for any transmitting device used in the 872-876 MHz band will be 33 dBm. This is the normal maximum power for a mobile station (handset) operating in the GSM bands.

Annex 8

Summary of SFR:IP responses relevant to the award

- A8.1 This annex sets out a summary of the responses made to the Spectrum Framework Review: Implementation Plan that are relevant to the spectrum award discussed in this document.
- A8.2 The full text of the responses can be found on the consultation section of the Ofcom website at. Twenty-nine respondents provided comments on the proposals for the award. Four respondents requested confidentiality. Their views have been taken into account, but their responses have not been published on the Ofcom website²³.

Issue	Comments	Ofcom’s response
Demand	<p>Airwave, Orange and O2 felt that Ofcom should retain the spectrum until further evidence of demand emerges.</p> <p>The TETRA MOU Association felt that the spectrum should not be auctioned yet but kept for international/cross country military/security use.</p>	<p>Ofcom recognises that demand for the spectrum is uncertain and that an award within the coming year might attract little, possibly no, interest from prospective bidders. Nevertheless it believes that this can only be truly tested by running an auction for the licence. This will allow interested parties to demonstrate whether or not there is demand for the spectrum. Ofcom will design the auction with the aim of encouraging participation. If the licence remains unsold Ofcom will reconsider the position on releasing the spectrum. This approach is in line with Ofcom’s policy of bringing unused spectrum to the market as soon as possible in order that the economic benefits may be reaped.</p>

²³ See <http://www.ofcom.org.uk/consult/condocs/sfrip/sfip/responses/>.

Award of available spectrum: 872-876 MHz paired with 917-921 MHz

Flexibility	<p>Crown Castle UK Limited felt that the spectrum should be offered to the market with as much flexibility as possible.</p>	<p>It is Ofcom's intention to give maximum flexibility by offering the 872-876/917-921 MHz spectrum without technology or usage restrictions other than those which appear necessary, such as power level, out-of-block emissions and duplex arrangement.</p>
Technological neutrality	<p>JRC suggested that if the spectrum is auctioned on a technology neutral basis it could be lost to TETRA 2 technology, and there will then be no spectrum available for TETRA 2.</p>	<p>Ofcom proposes to auction the spectrum on a technology and service neutral basis as this will give the market the opportunity to make the decision as to which service the spectrum can be most successfully used for. The market may decide that TETRA 2 is the most successful use of this spectrum.</p>
<p>GSM-R compatibility issues</p> <p>GSM compatibility issues</p>	<p>Network Rail strongly objected to Ofcom's proposal until compatibility issues with GSM-R had been addressed.</p> <p>The FCS felt that GSM-R users would need to be consulted on Ofcom's detailed proposals.</p> <p>O2 raised interference issues with their GSM network.</p>	<p>Ofcom believes that it has duly taken into account adjacent uses in defining its proposals for use of the Spectrum Bands, as set out in section 6 and Annex 7 in particular.</p>
Spectrum packaging and geographic coverage	<p>T-Mobile suggested that the available spectrum be awarded in multiples of 2x1.3 MHz.</p> <p>BAA stated a preference for local licences rather than a UK licence.</p> <p>The Telecommunications Association of the UK Water Industry felt that part of the spectrum should be released on the basis of geographic areas of coverage.</p>	<p>Ofcom considered whether the spectrum available should be split between a number of licences and whether regional or national licences should be offered. Demand for the spectrum is uncertain and it is unclear what technologies and services might be used. This means that there is no obvious basis on which to package the available spectrum. The spectrum is, moreover, relatively limited and splitting it into smaller packages may limit the possibilities for future use. This points to offering it</p>

		<p>as a single package. This view was shared by DotEcon and Analysys and Mason Communications in their report titled 'Allocation options for selected bands' dated February 2005. As the licence will be tradeable it would be possible to subsequently partition the spectrum into smaller blocks if that appeared viable in the light of market and technological developments.</p>
Auction design	<p>Orange did not support the proposal to have a first price, sealed bid auction for the reasons of transparency highlighted by DotEcon and Analysys and Mason Communications in their report titled 'Allocation options for selected bands' dated February 2005.</p>	<p>Ofcom considers that its proposal to hold a sealed-bid second price auction for the Spectrum Bands should ensure an efficient assignment process and optimal use of the bands. It also proposes to publish the details of all bids and bidders identities at the end of the award process. This is discussed in more detail at paragraphs 7.5 to 7.23 and 7.29.</p>
Auction participation	<p>A confidential respondent felt that the existing cellular operators should be restricted from obtaining this spectrum in an auction.</p>	<p>Ofcom has no plans to restrict the existing cellular operators, or any other class of licensee, from participating in the auction. Ofcom does not consider that there is a clear objective justification for such a restriction. Detailed rules for the auction will be contained in regulations that Ofcom intends to publish in draft by the end of 2006.</p>
Discriminatory licence terms	<p>MNOs argued that offering new spectrum licences to the market along the lines proposed in the SFR:IP could give rise to undue discrimination against existing licensees. They felt that various licence characteristics proposed in the document (such as technology and use neutrality, indefinite term, tradability and absence of</p>	<p>Ofcom does not consider that the proposals included in this document involve any undue discrimination against the holders of 2G and 3G licences or of any other existing licence. This is because the licence that Ofcom proposes to offer in the Spectrum Bands is different in numerous respects from existing 2G, 3G and other licences. By way of example, it differs in relation to</p>

	<p>roll-out obligations) could unduly discriminate against existing 2G and 3G licensees because the existing licences contain terms that are less advantageous.</p> <p>Vodafone, whilst generally agreeing with Ofcom's proposal, felt that the spectrum should not be used by a 3G service before 2008. They felt that award of new 3G spectrum before 2008 could have a detrimental effect upon investment and innovation in 3G services.</p>	<p>the quantity of spectrum available, the characteristics of the relevant frequencies, and the international regulatory environment, among other respects. The licence proposed for the Spectrum Bands constitutes a different type of class of licence from those already that exist for 2G and 3G services with rights that are different from the existing 2G and 3G licences. The proposals made by Ofcom in relation to the 872-876 MHz/917-921 MHz band are moreover, objectively justified. Ofcom considers that there can therefore be no undue discrimination against the existing 2G and 3G licensees. Also it should be noted that Ofcom is not proposing to place any restrictions in the auction rules on the holders of 2G or 3G licences (or for that matter any other person) from participating in the auction and competing to acquire the licence.</p>
<p>Expansion spectrum for IMT-2000/UMTS</p>	<p>Siemens Communications and the UMTS Forum suggested that the spectrum could be used for future IMT-2000/UMTS expansion.</p>	<p>Ofcom proposes to auction the spectrum on a technology and service neutral basis as this will give the market the opportunity to make the decision as to which service the Spectrum Bands can be most successfully used for.</p>

<p>Ofcom technical note</p>	<p>A confidential response disagreed with technical constraints detailed in the Ofcom technical paper published in February 2005 titled 'Technical constraints associated with the 917-921 MHz band', which they felt would prevent use of the band for wideband digital PAMR services.</p> <p>Flarion suggested that the proposed power of 2W in the technical paper is too low and a higher power is required to increase the attractiveness of the spectrum to as wide a cross section of the wireless market as possible.</p>	<p>Ofcom has explored the scope for greater flexibility for use of the Spectrum Bands than described in the February Note and has included revised technical proposals in this document. This is discussed in more detail at paragraphs 5.25 to 5.33 and section 6.</p>
<p>Short Range Devices (SRDs)</p>	<p>The UK Microwave Group expressed a concern that there was a need to minimise interference to Short Range Devices.</p>	<p>The spectrum licence will clearly identify the frequencies at which the radio equipment will operate and unauthorised transmissions on other adjacent frequencies will not be permitted.</p>
<p>Security applications</p>	<p>A confidential response suggested that likely future requirements for security applications should be fully addressed within the award process.</p>	<p>Ofcom proposes to auction the spectrum on a technology and service neutral basis as this will give the market the opportunity to make the decision as to which service the spectrum can be most successfully used for. Rather than imposing a particular use for the Spectrum Bands Ofcom would prefer the market itself to make any subsequent changes using, for example, trading and liberalisation.</p>

Annex 9

Characteristics of adjacent band use

- A9.1 It is the responsibility of interested parties to determine whether and to what extent existing uses in the frequencies adjacent to the Spectrum Bands are likely to affect their plans.
- A9.2 Relevant information on the use of Short Range Devices at 862-870 MHz can be found in the relevant Interface Requirement, IR 2030 – Short Range Devices. It is available at http://www.ofcom.org.uk/radiocomms/isu/licence_exempt/requirements/.
- A9.3 The technical specifications for GSM use currently appear in document 3GPP TS 45-005 version 7.4.0 (2006-01). It is available from 3GPP at <http://www.3gpp.org/ftp/Specs/html-info/45005.htm>.
- A9.4 The technical specifications for GSM-R use may be obtained from ETSI, under the reference ETSI TR 102 281 V1.0.0 (2004-09). At the time of publication of this consultation, ETSI offers free download of standards subject to a short registration process, at the following address: http://www.etsi.org/SERVICES_PRODUCTS/FREESTANDARD/HOME.HTM.
- A9.5 Links to external websites are correct as at time of publication. The documents may be updated from time to time.
- A9.6 Ofcom will also consider with MoD what information it should make available in future publications on this award concerning MoD use of the bands 870-872 MHz, 876-880 MHz, 915-917 MHz and 921-925 MHz.

Annex 10

Glossary

2G

“Two G”: second generation of mobile telephony systems using digital encoding. 2G networks support voice and limited data communications.

3G

The third generation cellular phone system, currently being deployed, which offers higher data rates than previous systems allowing services such as videophones.

AIP

Administered incentive pricing: a fee charged to users of the spectrum to encourage them to make economically efficient use of their spectrum.

Band

A defined range of frequencies that may be allocated for a particular radio service, or shared between radio services.

CDMA

Code Division Multiple Access: a radio transmission method where individual traffic transmissions use the same frequency, but where users' traffic is separated by means of different codes.

CEPT

Conference of European Postal and Telecommunications administrations, comprising over 40 European administrations.

Communications Act

Communications Act 2003, which came into force in 2003.

Co-ordination

This term refers to the process under which users seek to come to a mutual agreement to share access to a particular range of frequencies while avoiding undue interference.

dBW

Decibels above one Watt: a logarithmic representation of radio frequency power with respect to one Watt.

ECC

Electronic Communications Committee: a committee that reports to CEPT.

EIRP

Equivalent Isotropically Radiated Power: a theoretical measure of the power radiated by a transmitter/antenna - defined as the product of the power supplied to the antenna and the antenna gain in a given direction relative to an isotropic antenna.

GSM

Global System for Mobile communications: a 2G mobile phone technology. This is the technology behind the vast majority of 2G mobile phones used across Europe and is used by approximately 80% of 2G operators worldwide. Also sometimes referred to under its original meaning of “Groupe Spécial Mobile”.

GSM-R

A variant of the GSM standard developed specifically for use by the railways.

Harmful interference

Interference in relation to any wireless telegraphy (as described in section 19(5A) of the Wireless Telegraphy Act 1949)

which, in summary, includes interference that creates dangers or risks of dangers to the functioning of any radiocommunications service designed for the purposes of navigation or safety services, or interference that degrades, obstructs or repeatedly interrupts authorised broadcasting or other wireless telegraphy.

kHz

Kilohertz: a unit of frequency, equal to 1000 (1×10^3) Hz or cycles per second.

Liberalisation

Allowing licence holders to change the use to which they put their spectrum, within constraints to prevent interference.

Licence class

Type of licence issued by Ofcom, for example PAMR. Volume classes refer to those licence classes for which there are significant numbers of licensees, for example on site PBR with 26,000 licensees.

Licence exemption

Allowing anyone to use the spectrum for any application under certain specified restrictions, but typically with maximum power levels. The current regulations are the Wireless Telegraphy (Exemption) Regulations 2003 (SI 2003 No. 74), available at:

<http://www.legislation.hmso.gov.uk/si/si2003/20030074.htm>

MHz

Megahertz: a unit of frequency equal to 1,000,000 (1×10^6) Hz or cycles per second.

MoD

Ministry of Defence.

Ofcom

Office of Communications. Ofcom took over the RA's responsibility for spectrum management in the UK in December 2003.

Out-of-block emissions

Emissions cause by use of the spectrum covered by a particular authorisation that fall immediately outside the spectrum block covered by that authorisation.

Partial transfer

In a spectrum trading market, licence holders may transfer only a part of the rights and obligations associated with their spectrum licence - whereby the licence can be divided (e.g. partitioned) by geography, frequency and by time.

PAMR

Public Access Mobile Radio

PMR

Private Mobile Radio

PMSE

Programme Making and Special Events

Radiocommunications Agency

The Radiocommunications Agency: a former executive agency of the Department of Trade and Industry, which was responsible for the management of most non-military spectrum in the UK and for representing the UK in relevant international bodies. The RA's functions transferred to Ofcom in December 2003.

Spectrum Framework Review (SFR)

Ofcom consultation published in November 2004 and resulting statement published in June 2005 by Ofcom on how spectrum will be managed in the future.

**Spectrum Framework Review:
Implementation Plan (SFR:IP)**

Ofcom consultation published in January 2005 by Ofcom on the release of spectrum in 2005 – 08, and on extending spectrum liberalisation and trading to mobile services.

Spectrum mask

A way of specifying the amount of power that a transmitter is allowed to transmit into neighbouring frequency channels.

Spectrum trading

Process through which spectrum licence holders are able to transfer some or all of their rights to a third party.

TETRA

A digital two-way radio standard developed by the European Telecommunications Standards Institute (ETSI).

Trading Regulations

The Statutory Regulations that facilitate spectrum trading.

Wireless telegraphy

The means of sending information without the use of a wired system.

Wireless telegraphy licences

Licences issued under the Wireless Telegraphy Act 1949 (as amended).

Wireless Telegraphy Acts

Wireless Telegraphy Act 1949 and Wireless Telegraphy Act 1998 (both as amended).