



Determination to resolve Dispute between Opal Telecom and BT about Opal's Fixed Geographic Termination Rates

This version is the non-confidential version.
Confidential information and data have been redacted.
Redactions are indicated by “[X]”

Determination

Publication date: 26 October 2009

Contents

Section		Page
1	Summary	1
2	Introduction and Background	6
3	History of the dispute	13
4	Ofcom's Assessment of the Issues as set out in its Draft Determination	30
5	Responses to the consultation, Ofcom's conclusions, and final determination	52
Annex		Page
	The Determination	68

Section 1

Summary

- 1.1 This dispute relates to the proposed charges payable by BT plc (“BT”) for the termination of fixed geographic calls on Opal Telecom’s (“Opal”) network.
- 1.2 On 19 March 2009 Opal Telecom (“Opal”) issued Operator Charge Control Notice (“OCCN”) 654 to BT. This proposed a new fixed geographic termination rate for calls originating on, or transiting across, BT’s fixed network and terminating on Opal’s network, which would take effect from 1 October 2009. Opal’s proposed termination rate is equivalent to the BT Single Tandem termination rate, as published in BT’s current Carrier Price List¹.
- 1.3 On 9 April 2009 BT formally rejected OCCN 654.
- 1.4 On 3 June 2009, we received a submission from Opal requesting that Ofcom handle, consider and determine as a dispute whether the rate proposed by Opal is fair and reasonable in accordance with SMP Condition BC1 (CPs subject to SMP Condition BC1 are required to provide Network Access – in this case, fixed geographic call termination – on terms, conditions and charges that are fair and reasonable). On 9 June we sent a non-confidential copy of Opal’s submission to BT, asking them to comment on the scope of the dispute. On 16 June 2009, BT provided a response regarding the scope of the dispute.
- 1.5 Our powers and duties to resolve certain disputes are set out at sections 185-191 of the Communications Act 2003 (the 2003 Act). In accordance with Section 186(4) of the 2003 Act, on 26 June 2009 we decided that it was appropriate for us to handle this dispute, informed the parties to the dispute of our decision and published a Competition and Consumer Enforcement Bulletin entry setting out the scope of the dispute.²

Scope of the dispute

- 1.6 The scope of the dispute is:

“to determine whether the fixed geographic termination rate proposed by Opal to BT in its OCCN 654 with effect from 1 October 2009 for terminating on Opal’s network calls originating on, or transiting across, BT’s fixed network, is fair and reasonable in accordance with SMP Condition BC1; this rate being equivalent to the BT Single Tandem termination rate as published in their current Carrier Price List.”

- 1.7 In light of the scope, we have considered whether Opal’s proposed contractual change is fair and reasonable. Further, we have considered whether anything we have seen in the context of this dispute would justify us exercising any of our other regulatory powers under the Act. Although this dispute touches on important policy issues, particularly in the area of Next Generation Networks, we consider that these

¹ Opal’s proposed termination rate from 1 October 2009 (pursuant to OCCN 654) was: 0.3575 pence per minute (“ppm”) daytime; 0.1637ppm evening; 0.1289ppm weekend. Opal’s current termination rate was agreed under its current reciprocity agreement with BT: 0.2592ppm daytime; 0.1187ppm evening; 0.0935 weekend.

² See: http://www.ofcom.org.uk/bulletins/comp_bull_index/comp_bull_ocases/open_all/cw_01027/

wider issues are better dealt with in the context of the Next Generation Network project and we do not consider that these issues need to be resolved in order to resolve this dispute as defined in the scope.

The key issues

- 1.8 In submitting this dispute, Opal underpinned its argument by focusing on the differences in the technology being used by Opal and BT in their networks. BT has a network based on Time Division Multiplexing (TDM), whereas Opal has a 'Next Generation Network' ("NGN") using Internet Protocol ("IP"). This means that the traffic originating on BT's network must be converted from a TDM format to an IP format before it can be onward routed within the Opal network.
- 1.9 Opal considers that a rate which is equivalent to BT's Single Tandem termination rate is a fair and reasonable rate for calls which are delivered at its GSX (paragraph 3.78 (b)) for termination on its NGN network. This is because Opal considers there are two switching stages in its NGN network which have functions which are somewhat analogous to the tandem switch and Digital Local Exchange (DLE) switch (paragraph 4.24) in a TDM network. Opal believes that it would be possible for BT to interconnect to a lower point in its network, namely the ASX (paragraph 3.78 (d)), avoiding the GSX. This would be achieved through the delivery of IP traffic. Hence, Opal considers that a Single Tandem termination rate would better reflect the routing which occurs over its NGN network for traffic passed from BT to Opal via the GSX.
- 1.10 In contrast, BT has argued that there is only one level of switching in Opal's NGN. They consider that it would not be possible to interconnect to Opal's ASX and that therefore only costs for interconnect at DLEs are relevant (i.e. on BT's network, corresponding to the local exchange segment rate).
- 1.11 In resolving this dispute we have analysed the arguments of both parties by considering the technological basis for their arguments, which we regard as the key issue. We have also considered the relevant benchmarks, and analysed the arguments put forward by the parties in relation to the six principles of pricing and cost recovery. Further, we have considered our general statutory duties and Community obligations under sections 3 and 4 of the 2003 Act, to ensure that our decision is consistent with those duties.

Consultation on the Draft Determination

- 1.12 We issued a Draft Determination for consultation purposes on 11 September 2009 and received responses from five parties, BT, Opal, COLT, Cable & Wireless, and one which asked to remain anonymous.
- 1.13 BT and Cable & Wireless were supportive of the conclusions reached by Ofcom in our Draft Determination. The respondent who asked not to be named 'agreed to a reasonable extent' with our reasoning.
- 1.14 Opal and COLT were disappointed with our draft conclusion, with Opal noting that it did not consider that it represented a fair and reasonable solution to the dispute. Opal also considered that Ofcom had not adopted an appropriate framework for analysing whether the proposed termination rate was fair and reasonable. Opal went on to explain that it had submitted its dispute using a network analogy because it believes that this fitted with Ofcom's existing TDM-based policies on termination rates. It considered that our framework of analysis was flawed because, having reached the conclusion that BT and Opal's networks were not suitably analogous, we

did not adopt a different analytical framework based on examining why BT is able to charge a Single Tandem rate.

- 1.15 Opal's response also set out further reasoning as to why it should be able to charge BT's Single Tandem rate, namely, that it has to carry calls further on its own network because there are fewer points of interconnection in an NGN; and that it has to bear the cost of TDM to IP interworking.
- 1.16 COLT and the respondent who asked not to be named raised concerns with the current Reciprocity Agreement (see paragraphs 2.16 to 2.19); COLT also argued that Ofcom should consult on a new methodology for reciprocity. We consider that most of the issues raised in this regard are outside the scope of the current dispute; however, we have set out in Section 6 the principles underpinning reciprocity and our reasons for not prescribing a methodology to determine termination rates in this dispute.
- 1.17 Opal and Cable & Wireless in their responses requested guidance on how reciprocity should be implemented in relation to Next Generation Networks. Ofcom has recently consulted stakeholders on a range of issues arising from the deployment of NGNs³. We acknowledge the importance of this set of issues and we are now considering how to take these questions forward following the responses we have received both to the NGN consultation and to the consultation on the draft determination. We aim to set out our initial conclusions in the forthcoming NGN statement, and these may lead us to undertake further work. In the meantime, we remain of the view that the industry is best placed to take the issues forward by negotiation.
- 1.18 Section 4 sets out the analysis upon which we consulted in the Draft Determination. We have not amended this, but have instead provided further analysis, where necessary to address responses made to our Draft Determination, within Section 5. We have also used Section 5 to add clarity to certain statements we made in the Draft Determination, particularly where we consider that these could possibly lead to misunderstandings on the part of stakeholders. Finally, we have set out our final determination in Section 5, having considered and taken into account the responses received to our Draft Determination.

Our final determination

- 1.19 We do not accept Opal's argument that our framework of analysis was flawed. Our framework was set in light of our duties under the Act, the submissions of the parties and the scope of the dispute which was set after discussion with the parties and with their agreement.
- 1.20 Our fundamental concern about the network analogy advocated by Opal is that there are very significant differences in the network technologies and architectures of the BT network and the Opal NGN network. We consider that these differences make it difficult to make direct comparisons between the functions of components in the BT and Opal NGN networks in the manner suggested by Opal. To the extent that such a comparison can be made, we consider that the Opal network is not strongly analogous with the BT network in the manner suggested by Opal in its dispute submission.

³ Next Generation Networks: Responding to recent developments to protect consumers, promote effective competition and secure efficient investment; July 2009.
<http://www.ofcom.org.uk/consult/condocs/ngndevelopments/>

- 1.21 Our analysis suggests that Opal's IP network does not involve two switching stages, but is better characterised as having a single switching layer, the IP core. We consider that Opal's ASX is a call server, rather than a switch. We also consider that it is not possible for BT to interconnect directly to the ASX, with the IP core being the lowest level in Opal's network at which third parties can interconnect (using different interface nodes as between TDM and IP traffic).
- 1.22 In light of Opal's comments regarding the additional costs it incurs in carrying calls further on its network and the costs of TDM to IP interworking, we have undertaken additional analysis of Opal's cost model, submitted as part of the dispute, using Fully Allocated Costs. In doing so we are in no way suggesting that Opal's termination rate should be directly based on the cost that it actually incurs on its own network. We maintain our consistent view that the principle of reciprocity remains appropriate. Instead our purpose is to see if there is evidence that a termination rate lower than the Single Tandem rate would deny Opal the opportunity to recover its efficiently incurred cost. This analysis does not lend support to Opal's argument that a termination rate equivalent to BT's Single Tandem would be fair and reasonable.
- 1.23 We also considered one interpretation of BT's argument, which is that because the GSX is "the point nearest to the customer where signals can be exchanged in the Opal IP Network", it should be BT's DLE rate which applies, as opposed to the weighted average derived from the industry Reciprocity Agreement. Our comparison of the Opal and BT networks does not support such an argument, given the differences in architecture and topology of the Opal network and, in particular, the centralisation of the switching and interconnection functions in the Opal network. To the extent that any comparison between Opal's and BT's networks can be made, we consider that GSX interconnection on Opal's network is better characterised as corresponding to two interconnection services on BT's network - local exchange segment and Single Tandem – than to local exchange segment alone.
- 1.24 In previous cases we have found that the Reciprocity Agreement that expired on 30 September 2009 is one way of arriving at a fair and reasonable termination rate taking into account the mix of services provided. However, due to changing circumstances, such as the introduction of NGNs, other ways of arriving at rates might additionally or alternatively be fair and reasonable. We note that BT and the industry are negotiating a revised Reciprocity Agreement to replace the one that expired on 30 September 2009.
- 1.25 Having considered the representations made to us on the Draft Determination, we are now determining that, should Opal provide fixed geographic termination to BT on the terms set out in OCCN 654, such provision would not be regarded as being on fair and reasonable terms, conditions and charges under SMP Condition BC1. Our formal Determination is set out in Annex 1.
- 1.26 In light of our Determination that Opal's proposed termination rate is not fair and reasonable the parties should continue to do business on the terms and conditions that have applied so far. We note that, in light of ongoing industry negotiations about future reciprocity agreements, the parties may choose to conduct further negotiations to agree an alternative method of deriving a termination rate, provided always that any such alternative rate is fair and reasonable.
- 1.27 The background to this dispute is set out in **section 2**; the history to this dispute is set out in **section 3**; the analysis and reasoning underpinning the Draft Determination are set out in **section 4**; and the responses to consultation on the

Draft Determination and our consideration of the points raised in these responses are set out in **Section 5**.

Section 2

Introduction and Background

Dispute resolution

Ofcom's duty to handle disputes

- 2.1 Section 185(1)(a) of the Communications Act 2003 ("the Act") provides (in conjunction with section 185(3)) that in the case of a dispute relating to the provision of network access between different communications providers, any one or more of the parties to such a dispute may refer it to Ofcom.
- 2.2 Section 186 of the Act provides that where a dispute is referred to Ofcom in accordance with section 185, Ofcom must decide whether or not it is appropriate to handle it. Section 186(3) further provides that Ofcom must decide that it is appropriate for it to handle a dispute unless there are alternative means available for resolving the dispute, a resolution of the dispute by those means would be consistent with the Community requirements set out in section 4 of the Act, and those alternative means would be likely to result in a prompt and satisfactory resolution of the dispute.
- 2.3 In summary therefore, where a dispute which falls within section 185(1)(a) of the Act is referred to Ofcom, and Ofcom can not identify alternative means which meet the criteria set out above, it has a duty to decide that it is appropriate to handle that dispute.
- 2.4 Section 188 of the Act provides that where Ofcom has decided that it is appropriate for it to handle a dispute, Ofcom must make a determination resolving the dispute within four months, except in exceptional circumstances.

Ofcom's powers when determining a dispute

- 2.5 Ofcom's powers in relation to making a dispute determination are limited to those set out in section 190 of the Act. Except in relation to dispute relating to the management of the radio spectrum, Ofcom's main power is to do one or more of the following:
 - 2.5.1 Make a declaration setting out the rights and obligations of the parties to the dispute,
 - 2.5.2 Give a direction fixing the terms or conditions of transactions between the parties to the dispute,
 - 2.5.3 Give a direction imposing an obligation to enter into a transaction between themselves on the terms and conditions fixed by Ofcom, and
 - 2.5.4 Give a direction requiring the payment of sums by way of adjustment of an underpayment or overpayment, in respect of charges for which amounts have been paid by one party to the dispute, to the other.
- 2.6 A determination made by Ofcom to resolve a dispute binds all the parties to that dispute (section 190(8)). Whilst Ofcom's dispute resolution powers can therefore only bind the parties to a dispute on a bilateral basis, we would expect dispute determinations to be read across and followed in situations where other parties who

were not a party to the dispute, are facing similar questions vis-à-vis one of the parties to the dispute which has been determined.

Ofcom's duties when determining a dispute

2.7 The dispute resolution provisions set out in sections 185-191 of the Act are functions of Ofcom. As a result, when Ofcom resolves disputes it must do so in a manner which is consistent with both Ofcom's general duties in section 3 of the Act, and (pursuant to section 4(1)(c) of the Act) the six Community requirements set out in section 4 of the Act, which give effect, amongst other things, to the requirements of Article 8 of the Framework Directive⁴.

Summary of the dispute brought in this case - call termination

2.8 This dispute relates to the charges payable by BT for the termination of fixed geographic calls on Opal's network from October 2009, as proposed by Opal.

2.9 Communications providers ("CPs") buy call termination services from each other in order to provide their customers with end-to-end calls between different networks. In the case of this dispute, BT pays Opal for termination of calls on Opal's network.

2.10 The network to which the caller is connected is called the 'originating network' and the communications provider is known as the Originating Communications Provider ('OCP'). Similarly the network on which the call terminates is called the 'terminating network' and the communications provider is known as the Terminating Communications Provider ('TCP'); not all originating networks have a direct connection to all terminating networks. Some CPs who originate traffic therefore pass calls for termination via other networks (most commonly BT's network), purchasing a transit service from that operator to do so. In the case of originating networks purchasing transit via BT's network to a third party's network, the total charge payable to BT by those CPs will reflect charges for transit across BT's network and the costs of termination on the third party network.

SMP in fixed geographic call termination

2.11 On 28 November 2003 Ofcom published the findings of its Review of fixed geographic call termination markets⁵ ("the 2003 Market Review").

2.12 In the 2003 Market Review, Ofcom found that the provision of fixed geographic call termination services on each CP's network constitutes a separate market. The Market Review designated each of the CPs as having significant market power ("SMP") in the markets for fixed geographic call termination on their own networks and imposed certain SMP conditions on those CPs, as set out in the notification which accompanied that review.

2.13 The fixed geographic call termination market was reviewed again as part of Ofcom's 2009 Review of the fixed narrowband services wholesale markets⁶ published on 15 September 2009 ('the 2009 Market Review'), and therefore after the publication of our Draft Determination.

⁴ Directive 2002/21/EC of 7 March 2002

⁵ Review of fixed geographic call termination markets Identification and analysis of markets, determination of market power and setting of SMP conditions: Final Explanatory Statement and Notification, 28 November 2003 http://www.ofcom.org.uk/consult/condocs/narrowband_mkt_rvw/Eureviewfinala1.pdf

⁶ http://www.ofcom.org.uk/consult/condocs/wnmr_statement_consultation/main.pdf

- 2.14 In the 2009 Market Review, Ofcom again found that each CP's network constitutes a separate market, that each of the CPs held significant market power ("SMP") in the markets for fixed geographic call termination on their own networks and imposed SMP conditions on those CPs that mirrored the SMP conditions that had previously been imposed on CPs under the 2003 review⁷. The full SMP conditions are set out in the notification which accompanied that review.
- 2.15 BT is subject to SMP Condition BA1⁸ which requires it to provide Network Access (in this case, fixed geographic call termination) on terms, conditions and charges that are fair and reasonable.
- 2.16 In addition, BT is subject to SMP Condition BA3⁹, which requires it to base its charges for fixed geographic call termination on forward looking long run incremental costs ("LRIC")¹⁰, and SMP Condition BA4¹¹, which imposes a charge control on BT's fixed geographic call termination charges.
- 2.17 Kingston was also designated¹² as having SMP in the market for fixed geographic call termination on its networks. As a result, Kingston is subject to SMP condition BB1¹³ which requires it provide network access (that is fixed geographic call termination services) and to do so on fair and reasonable terms. The obligation applies to Kingston's call termination services throughout the UK. Kingston is also subject to SMP condition BB3¹⁴ which requires Kingston to set charges on the basis of its forward looking long run incremental costs. This condition applies to the Hull area only.
- 2.18 Other CPs¹⁵ were also designated as having SMP in the market for fixed geographic call termination on their respective networks. These CPs are consequently subject to SMP Condition BC1¹⁶ which requires them to provide Network Access (in this case, fixed geographic call termination) on terms, conditions and charges that are fair and reasonable. This condition ensures that these Other CPs are not able to exploit the SMP they enjoy in respect of fixed geographic call termination on their own networks by the imposition of excessive charges, the harmful effects of which would ultimately be borne by consumers.

⁷ There is one additional SMP condition that is being further consulted on as part of the review, but as it is not in force and it relates only to a publication obligation it is not considered relevant to this dispute.

⁸ As set out at part 2 of Schedule 1 of the Notification to the Market Review.

⁹ As set out at part 2 of Schedule 1 of the Notification to the Market Review.

¹⁰ This allows an appropriate mark up for the recovery of common costs – i.e. LRIC+

¹¹ As set out at part 2 of Schedule 1 of the Notification to the Market Review.

¹² Under Schedule 1 (BT) and Schedule 2 (Kingston) of the Notification set out at Annex B to the Market Review http://www.ofcom.org.uk/consult/condocs/narrowband_mkt_rvw/Eureviewfinala1.pdf

¹³ See page 63 of the Review of fixed geographic call termination markets, Identification and analysis of markets, determination of market power and setting of SMP conditions: Final Explanatory Statement and Notification, 28 November 2003.

http://www.ofcom.org.uk/consult/condocs/narrowband_mkt_rvw/Eureviewfinala1.pdf

¹⁴ See page 65 of the Review of fixed geographic call termination markets, Identification and analysis of markets, determination of market power and setting of SMP conditions: Final Explanatory Statement and Notification, 28 November 2003.

http://www.ofcom.org.uk/consult/condocs/narrowband_mkt_rvw/Eureviewfinala1.pdf

¹⁵ The CPs named under Annex A to Schedule 3 of the Notification to the 2003 Market Review and Annex A to Schedule 3 of Annex 7 of the 2009 Market Review.

¹⁶ As set out at part 2 of Schedule 3 of the Notification to the 2003 Market Review and part 2 of Schedule 3 of the Notification to the 2009 Market Review.

2.19 All of these conditions were imposed by the 2003 Market Review and again by the 2009 Market Review, so they have had and continue to have effect throughout the full history, and our consideration, of this dispute.

How BT seeks to comply with its SMP Conditions

2.20 In seeking to comply with these obligations and similar obligations in place prior to changes in regulatory rules introduced in 2003, BT publishes a Carrier Price List (“CPL”). Among other things, this sets out at section B1, part 1.01, the charges for “BT Telephony Calls to the BT System” – i.e. the charges BT applies to OCPs for terminating fixed geographic calls on the BT network. Different pence per minute charges are applied to each call depending on the time of day the call is made and the level within the BT network that the call is handed over to BT by the OCP:

- The “Call Termination Local Exchange” rate applies to calls handed by the OCP to BT at the local exchange for the network termination point relevant to that call;
- The “Single Tandem Call Termination” rate applies to calls handled by the OCP to BT at the tandem exchange connected to the relevant local exchange for that call; and
- The “Double Tandem Call Termination” rate applies to calls handled by the OCP to BT at other tandem exchanges within the BT network, with different charges applying dependent on the radial distance between the tandem exchange to which the call is handed and the tandem exchange connected to the relevant local exchange for that call.
 - “Double Tandem (short)” rates apply when the radial distance is less than 100km;
 - “Double Tandem (medium)” rates apply when the radial distance is between 100km and 200km; and
 - “Double Tandem (long)” rates apply when the radial distance is greater than 200km.

Reciprocal charging

2.21 Since 1997 charges for fixed geographic call termination on networks other than the BT and Kingston networks have since 1997 been calculated on the basis of a principle of reciprocal charging. Under this principle, Terminating Communication Providers’ (“TCP”) charges for fixed geographic call termination services are based on BT’s equivalent regulated, cost-oriented charges.

2.22 In both the 2003 and 2009 Market Reviews and in other decisions¹⁷ Ofcom said that it considered that this reciprocal arrangement addresses the potential effects of SMP in fixed geographic call termination markets. In other words, Ofcom has stated that if a CP’s termination rates are suitably reciprocal with BT’s they are *de facto* fair and reasonable and compliant with SMP condition BC1.

How the current reciprocity agreement works

2.23 Charges for the termination of calls originated on BT’s network (or transiting across it) and terminated on Opal’s network are subject to a reciprocity agreement – this expired

¹⁷ See Ofcom’s Resolution of a dispute between BT and Telewest about reciprocal charging arrangements for call termination rates, 16 April 2004.

on 30 September 2009. The Reciprocity Agreement, which is implemented across industry, distinguishes between TCPs with single switched status (Single Switched Operators or “SSOs”) and TCPs with multi switched status (Multi Switched Operators or “MSOs”). Single switched termination calls are calls that are switched by the TCP’s local exchange to a Network Termination Point that is directly connected to that local exchange, and multi-switched calls are calls that are switched by one or more of the TCP’s tandem exchanges and thereafter switched by a local exchange to a Network Termination Point directly connected to that local exchange.

2.24 The single switched call charge (charge “A”) is calculated as a weighted average of BT’s “Single Tandem Call Termination” and “Local Exchange Call Termination charges”¹⁸. A weighting factor, known as ‘X’, is applied to the calculation to reflect the mix of geographic call termination traffic sent from the CP to the relevant BT tandem and local exchange switches for termination on the BT network (this also takes account of any relevant local exchange Carrier Pre-Select (CPS) traffic the CP may receive from BT). Specifically, the X factor is used to weight the Single Tandem Call Termination charge. These proportions (Single Tandem and Local Exchange) are calculated on the basis of a sample of traffic each May, and then applied to the charge which is applied in October for the following year. Thus the X ratio is dynamic (with a slight time lag) and personalised to each network (e.g. Opal) depending on how that network interconnects with the BT network.

2.25 For MSOs, the termination charge paid by BT (charge “B”) is a weighted average of charge “A” (as above) and the BT Double Tandem (short) rate¹⁹. The weights applying to these two charges are set by the proportion of traffic sent from BT to the other CP’s network that is multi-switched (“Y” ratio) and the proportion which is single switched (1-Y).

2.26 Textbox 1 below sets out more formally the calculation of charges A and B.

Textbox 1 – calculation of fixed geographic termination rates

Rate A – Single Switch Operator rate

The Operator’s May invoice from BT is analysed to identify:

- Total number of minutes sent to BT at local exchange rate
- CPS local exchange call minutes
- Total number of minutes sent to BT at Single Tandem rate

This data is then used to calculate the weighting factor ‘X’, where:

- $X = (\text{Total number of minutes sent to BT at local exchange rate} + \text{CPS local exchange call minutes}) / (\text{Total number of minutes sent to BT at local exchange rate} + \text{CPS local exchange call minutes} + \text{total number of minutes sent to BT at Single Tandem rate})$

Then a rate for each time of day is calculated:

¹⁸ These charges form part of the Network Charge Controls (“NCC”). The daytime rates for April 2005 were: 0.2514ppm for DLE termination and 0.3555ppm for ST termination.

¹⁹ The Double Tandem (short rate) charge is also one of the NCC charges, and was 0.6055 (daytime) as of April 2005.

- Rate A = (X x BT Call Termination Local Exchange rate) + ((1 - X) x BT Single Tandem Call Termination rate)

Rate A will change whenever the rates in BT's Carrier Price List change.

X will be set for 12 month period from 1 October based on the May call analysis.

Rate B – Multi-Switch Operator rate

Ratio Y is the percentage of all “relevant minutes” sent by BT to the Operator which are minutes terminated as Multi-Switched Calls.

Ratio Y is checked and calculated twice yearly in May and November.

If Y falls below lower threshold of 7.5% for two consecutive calculations, then the Operator loses MSO status and rate A will apply until Y exceeds 10% as set out above.

Rate B is calculated as:

- Rate B = (Y x BT Double Tandem (short) rate) + ((1-Y) x rate A)

Rate B changes when BT's Carrier Price List conveyance charges change and when rate A changes in line with recalculation of X.

Y is recalculated twice a year using May and November data.

Internet Protocol and Next Generation Networks

2.27 Key to this dispute is the difference between the networks of Opal and BT. Opal has developed a Next Generation Network (“NGN”) which utilises Internet Protocol (IP). An NGN is generally understood to refer to an IP network capable of being used for both voice and data, and in which there is some control over quality of service. The key features of an NGN are that it is a packet-based, multi-service network, which has a clear separation of transport and control, and where the control functions may reside on a physically separate network. IP is a protocol which is used to send data across the Internet, and now in many other networks. IP defines the addressing system on the Internet and allows different IP datagrams (packets) to be routed to the correct destination.

2.28 BT's network is based on Time Division Multiplexing (“TDM”). TDM refers to technologies and methods of putting multiple data streams in a single signal by separating each signal into many segments, each having a very short duration. Each individual data stream is re-assembled at the destination based on timing.

BT's 21st Century Network

2.29 21CN is an investment programme, announced by BT in 2004, designed to upgrade its network infrastructure and systems. The original network architecture was designed to deliver a single IP-based NGN, which would replace numerous service specific platforms in the legacy architecture. This included replacing the existing TDM-based voice network in its entirety.

- 2.30 In 2004, when details first started to emerge of BT's plan to build an NGN through its 21st Century Network ('21CN') programme, NGNs were seen as perhaps the most important development in telecoms since privatisation. At the time, it was thought that they might represent a change of such magnitude as to require a different approach to regulation.
- 2.31 For the past five years, since BT announced its intention to build 21CN, the expectation has been that in the not too distant future, BT would replace its Public Switched Telephone Network ('PSTN') in its entirety. Following a strategic review of its plans for 21CN, BT has decided to step back from this vision of a complete replacement of its PSTN.
- 2.32 It is now expected that parts of BT's PSTN will be replaced as and when needed, for example when equipment reaches the end of its useful economic life. The focus for future investment is on upgrading the access network with fibre to the cabinet ("FTTC") and fibre to the premises ("FTTP"). These deployments are likely to be accompanied by core NGNs to deliver telephony and other services. However, the design of this future all-fibre NGN could be very different from the architecture originally envisaged for BT's 21CN and also used by other fixed-network CPs.
- 2.33 This change in outlook has created considerable uncertainty. Although most CPs expect NGN technology to be adopted in the future, it is no longer possible to say with any degree of certainty how or when this will happen. Ofcom is currently consulting on these and a range of other issues related to NGN²⁰.

Ofcom's 2009 Market Review

- 2.34 Ofcom finalised its review of the fixed narrowband services wholesale markets and, as discussed above, published its final statement on 15 September 2009.
- 2.35 Amongst other things in the market review, Ofcom considered the implications of the introduction of IP based Next Generation Networks on call termination charges. Ofcom continued to be of the view that, in the context of call termination charges, "fair and reasonable" should include the principle of reciprocity, taking into account differences in networks, and that BT's costs are likely to be close to those of an efficient network.
- 2.36 The 2009 Market Review noted that in the past industry²¹ has used the Reciprocity Agreement as the mechanism for setting termination charges. The current Reciprocity Agreement is due for renegotiation, given that it expired on 30 September 2009. We would expect that this negotiation will address the migration between legacy networks and NGNs in such a way that CPs who migrate at different speeds are not unduly penalised. We continue to be of the view that it is appropriate for industry to establish this agreement rather than Ofcom imposing it as a regulatory requirement.

²⁰ Next Generation Networks: Responding to recent developments to protect consumers, promote effective competition and secure efficient investment, 31 July 2009.

<http://www.ofcom.org.uk/consult/condocs/ngndevelopments/main.pdf>

²¹ This refers to Terminating Communications Providers who have used the Reciprocity Agreement under a consensus approach.

Section 3

History of the dispute

- 3.1 According to the evidence submitted by the parties Opal first wrote to BT on 18 December 2008 requesting a review of the current Reciprocity Agreement, as Opal considered that it does not adequately take into account the nature of its Next Generation Network (NGN). Opal and BT met on 27 January 2009, at which discussions focused on BT using Internet Protocol (IP) interconnection to route calls to Opal's ASX switches, rather than Time Division Multiplexing ('TDM') interconnection which is used currently. The parties met again on 5 February 2009 at which the industry review of reciprocity arrangements was discussed.
- 3.2 Opal issued its proposed termination rate to BT on the 19 March 2009 in OCCN 654²². OCCN 654 set out a proposed fixed geographic termination rate with an effective date of 1 October 2009, when the current reciprocity agreement runs out. The proposed rate would apply to calls originating on, or transiting across, BT's fixed network for termination on Opal's fixed network. The proposed and current rates are set out in Table 1 below. [Opal's submission also refers to benchmarks termination rates for BT's Single Tandem, Kingston Communications, Virgin Media and BT IP Exchange. These are also set out in Table 1 and will be referred to throughout Section 3].

Table 1: Opal's Current, Proposed and Benchmark Termination Rates

Operator	Daytime ppm	Evening ppm	Weekend ppm
Opal's Current and Proposed Termination Rates			
Opal's termination rate under the current Reciprocity Agreement	0.2592	0.1187	0.0935
Opal's Proposed rate	0.3575	0.1637	0.1289
Benchmark Termination Rates			
BT Single Tandem	0.3575	0.1637	0.1289
Kingston (Hull Area)	0.4135	0.1893	0.1491
Virgin Media	0.3049	0.1396	0.1099
BT IP Exchange	0.3575	0.1637	0.1289

²² The OCCN is the mechanism used by BT and other ECPs for proposing and amending charges for access to their networks, as set out in BT's Standard Interconnect Agreement.

- 3.3 The proposed termination rate was formally rejected by BT on 9 April 2009, following a conference call between the parties on the same date.
- 3.4 On 2 June 2009 BT held its first cross-industry workshop to discuss the new reciprocity framework; this was attended by Opal.
- 3.5 On 3 June 2009 Opal submitted this dispute to Ofcom. It asked Ofcom to resolve this dispute by determining that the proposed termination rate proposed in OCCN 654 represents a 'fair and reasonable' outcome between the parties to the dispute in accordance with SMP condition BC1.

Scope of the dispute

- 3.6 As set out above, sections 185 to 191 of the 2003 Act set out Ofcom's dispute resolution powers. They apply to disputes relating to the provision of network access and to other disputes relating to the rights and obligations conferred or imposed by or under Part 2 of the 2003 Act. Section 186 of the 2003 Act requires Ofcom to resolve a dispute referred to it under section 185 once it has decided in accordance with section 186(2) to handle the dispute. Ofcom's remedial powers for resolving disputes are set out in section 190 of the 2003 Act.
- 3.7 Having considered the parties' submissions and subsequent information, Ofcom was satisfied that the dispute Opal had asked it to resolve is a dispute between communications providers (CPs) relating to network access, and that the matters in dispute would not be resolved through further negotiation between the parties. On 26 June 2009 Ofcom decided it was appropriate for it to handle the dispute and opened an investigation into the dispute and published details of the scope of the investigation for consultation on its on-line Competition and Consumer Enforcement Bulletin.²³
- 3.8 The scope of the dispute is to determine whether the fixed geographic termination rate proposed by Opal to BT in its OCCN 654 which would come into effect from 1 October 2009, is fair and reasonable in accordance with SMP Condition BC1; this rate being equivalent to the BT Single Tandem termination rate as published in BT's current Carrier Price List.
- 3.9 In line with its standard procedures in disputes, Ofcom invited comments from Opal and BT on the scope of the dispute as originally published. Neither Opal nor BT commented on the scope, which was confirmed on 7 July 2009.

Stakeholders interested in the outcome of the dispute

- 3.10 Upon opening the dispute for resolution, Ofcom invited interested stakeholders to express an interest in the outcome of this dispute. Five stakeholders expressed an interest:
 - Cable and Wireless plc
 - Colt Telecommunications
 - KCOM Group plc
 - TelXL Limited

²³ http://www.ofcom.org.uk/bulletins/comp_bull_index/comp_bull_ocases/open_all/cw_01027/

- Virgin Media

Information sought by Ofcom

- 3.11 Ofcom invited BT to comment on Opal's submission and they did so on 16 June 2009. Following the opening of the dispute BT presented their understanding of Opal's NGN and why they felt the proposed rate was not fair and reasonable at a meeting with Ofcom on 10 July 2009; BT subsequently submitted comments on Opal's submission to Ofcom on 15 July. Opal commented on BT's submission on 31 July 2009.
- 3.12 On 23 July 2009, Ofcom sent Opal a notice under section 191 of the 2003 Act requiring it to provide information in connection with this dispute (this request was sent in draft on 21 July 2009). We received this information from Opal on 31 July 2009 and held a meeting with them on 4 August 2009 to discuss their response.

The submissions of the parties

- 3.13 This section outlines the main arguments of the parties to the dispute. It has been set out in chronological order to show the development in Opal's arguments during the course of the dispute; this development appears to reflect BT's response to Opal's initial submission and our subsequent request for further information from Opal.

Opal's arguments

- 3.14 Opal argues that to understand the basis for the termination rate proposed by Opal it is necessary to understand the background to the nature of its fixed network. Opal launched its local loop unbundling network in April 2006 and to date has transferred over 1.5 million of its customers to its network. Consequently, Opal terminates all calls destined for these customers and charges BT (and other directly interconnected operators) a call termination charge for such calls.
- 3.15 Opal stated that the termination rate currently charged by Opal has been set in accordance with its current Reciprocity Agreement with BT. The current Reciprocity Agreement sets out a methodology [see Section 2 paragraphs 2.13 to 2.16] and formula for calculating Opal's termination rate based on the balance of the traffic delivered by Opal to BT's network. Opal's current termination rate is therefore based on a mixture of BT's local and Single Tandem termination rates²⁴. Opal contends that this rate does not reflect the way in which calls are routed across Opal's next generation network and how BT terminates traffic on it.
- 3.16 Opal's view is that, whilst there are some technological and topological differences between NGN and TDM networks, when Opal receives a call from BT's TDM network, Opal's network will essentially switch the call at least twice before termination at the customer's premises. As such, Opal believes that it should receive the termination rate which is received by BT when it switches calls twice across its TDM network i.e. the Single Tandem rate.
- 3.17 Opal states that a call will first be conveyed across its GSX, which converts the call from TDM to IP and which Opal believes is analogous to a tandem switch on a TDM network. After this, the call will be switched by an ASX, which Opal considers is analogous to a local switch on the TDM network, as it performs many similar functions

²⁴ Opal is also receiving some uplift as an MSO on 3.9 per cent of the traffic originating on BT's network, although this is likely to end when the levels fall below the 7.5% threshold for two consecutive review periods.

(Figure 1). Opal also suggested that BT could interconnect at a lower level in its network i.e. with the ASX, once it had converted its network to IP.

Figure 1: Opal's view of termination of calls on Opal's NGN

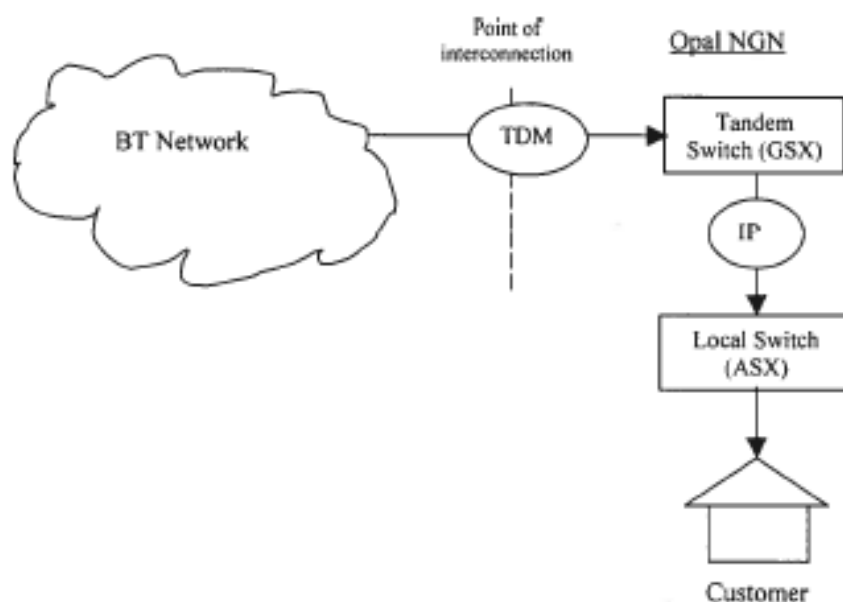

Source: Opal

- 3.18 Opal explained that the tandem switch in Figure 1 is a Sonus GSX that is capable of receiving calls in conventional TDM form and converting them to IP calls for onward conveyance on Opal's network. Opal explained that the local switch in Figure 1 is a Sonus ASX that is capable of switching IP traffic. Opal also stated that the ASX switch is sometimes referred to as a 'call server' in NGN technology. Opal therefore argues that the routing of the call in its own network is virtually identical to how a call would be routed in over one tandem switch and one local switch in BT's network before terminating at the premises of the BT customer. Opal states that in the case of BT it would levy a call termination rate at Single Tandem level if the call were routed in this manner across its network.
- 3.19 Opal argued that the current Reciprocity Agreement between Opal and BT does not allow Opal to recover a termination charge at BT's Single Tandem level. The current Reciprocity Agreement provides that Opal's termination rate is based on the average termination rate that Opal pays for terminating calls on BT's network (effectively a weighted average of BT local and Single Tandem termination rate). Opal's fundamental concern with the current Reciprocity Agreement is therefore that it does not allow Opal to charge a call termination rate which reflects the way in which calls are actually routed in its network.
- 3.20 Opal believes it should be able to charge a higher termination rate that adequately reflects the actual routing of the calls in Opal's network. Opal considers that the most appropriate way of addressing this issue is to levy a termination rate that is equivalent to BT's own Single Tandem termination rate. On 19 March, Opal issued an Operator Charge Change Notice ("OCCN") 654 to BT in which it proposed to increase the

current termination rate to those set out in Table 1. This would take effect on 1 October 2009.

- 3.21 In submitting this dispute, Opal also put forward estimates of the cost floor and ceiling for its own network, using a cost model. Opal claims that this model uses the same accounting and cost allocation principles as Ofcom does when setting BT's network charge controls. The objective of Opal's cost model is not to determine the termination rate; instead Opal argues that it is a valuable 'sense check' that supports the use of BT's Single Tandem rate, because the proposed call termination rate falls well within the estimated cost floor and ceiling shown in Table 2.

Table 2: Estimated call termination costs for Opal (pence per minute, 24 hour average²⁵)

Estimated cost floor	[§<] ppm
Estimated cost ceiling	[§<] ppm
Proposed termination rate	0.23 ppm

The six principles of pricing and cost recovery

- 3.22 Opal submits that the proposed termination rate is fair and reasonable and therefore complies with SMP Condition BC1. It argues that when assessing whether the termination rate is fair and reasonable, Ofcom's six principles of pricing and cost recovery should form the relevant frame of reference. The six principles of pricing and cost recovery are:
- a. **Cost causation:** costs should be recovered from those whose actions cause the costs to be incurred;
 - b. **Cost minimisation:** the mechanism for cost recovery should ensure that there are strong incentives to minimise costs;
 - c. **Effective competition:** the mechanism for cost recovery should not undermine or weaken the pressures for effective competition;
 - d. **Reciprocity:** where services are provided reciprocally, charges should also be reciprocal;
 - e. **Distribution of benefits:** costs should be recovered from the beneficiaries especially where there are externalities; and
 - f. **Practicability:** the mechanism for cost recovery needs to be practicable and relatively easy to implement.

Cost Causation

- 3.23 The cost causation principle states that costs should be recovered from those whose actions cause them to be incurred. Opal has cited Ofcom's "Determination to resolve a dispute between BT and Telewest about geographic call termination reciprocity

²⁵ Opal derived the 24 hour average for the proposed termination rate using weights reflecting the time of day split in its traffic.

agreement”²⁶. In this determination Ofcom stated that: “In this context, BT as the originating operator, is causing the costs of termination on Telewest’s network to be incurred, and thus should be the party responsible for bearing the costs”. Opal argues that its proposed charge for termination would be consistent with this view of cost causation because it reflects the efficient level of costs incurred when a call is terminated on Opal’s network.

- 3.24 Opal notes that the principle of cost causation raises the issue of whether the network operator causing the cost to be incurred is able to reduce its costs by routing efficiently. In relation to this dispute, Opal argues that an important issue of principle is raised in relation to the emergence of NGN. Opal’s NGN is built using IP technology whereas BT’s network is based on TDM technology. For some years BT has been in the process of converting its existing network to a NGN under its 21CN programme – however, this has now been delayed.
- 3.25 Presently, Opal considers that BT is unable to connect directly to Opal’s local ASX switch because BT has not developed an IP interconnection service. According to Opal, the calls received from BT are handed over at the equivalent of a tandem layer (the GSX). Opal states that it has never prevented BT from handing over calls directly to the ASX in IP form and would be happy to use IP interconnection with BT and would consequently consider a lower termination rate. Opal argues that this is relevant from a cost causation perspective because it is BT who causes Opal to incur the additional cost of TDM to IP interworking, and thereby creating the need for a tandem layer in Opal’s network.
- 3.26 Having successfully made the transition to an NGN, Opal argues that it would be inherently unfair if it were prevented from levying a termination charge reflective of how it actually conveys calls simply for the reason that BT has failed to implement a similar network.
- 3.27 Opal therefore believes that its proposed termination rate is consistent with the principle of cost causation by requiring BT to pay the costs that Opal efficiently incurs when terminating a call on its network.

Cost Minimisation

- 3.28 The principle of cost minimisation should facilitate productive efficiency by providing an incentive to minimise costs. Opal submits that its proposed termination rate is consistent with this principle and its objective.
- 3.29 Opal argues that the setting of a termination rate that is different to actual efficiently incurred costs could be considered to provide a disincentive for cost minimisation and thereby influence whether decisions to enter the market are made on an efficient (or inefficient) basis. Opal would argue the incentive on extant firms in the market to reduce their own termination costs remains unchanged even if the termination charge does not precisely equal costs.
- 3.30 If an operator is able to charge the industry regulated rate regardless of the technology and business strategy it chooses to adopt, it will benefit if it is able to lower its costs below those of its competitors. This allows participants in regulated markets to retain an incentive to invest and innovate which could result in long-term industry cost

²⁶ Determination to resolve a dispute between BT and Telewest about geographic call termination reciprocity agreement, 16 June 2006.
http://www.ofcom.org.uk/bulletins/comp_bull_index/comp_bull_ccases/closed_all/cw_890/determination.pdf

reductions and product improvements. Opal cites the recent TRD Judgement²⁷ as evidence to support the retention of these incentives:

“It is important therefore not to allow benchmarking against actual or proposed prices controls to be used in a way which deprives the undertakings of the benefits of cost reductions and other efficiency savings which such controls were intended to encourage”.

3.31 According to Opal, it could also be argued that setting an operator’s termination charge equal to their costs might weaken the incentive for cost minimisation, because operators would not benefit from the cost savings they make. Opal argues that this reasoning is also supported by the ERG’s ‘Common position on symmetry of fixed call termination rates and symmetry of mobile call termination rates’, which states that:

“Unlike a unique efficient termination rate level, asymmetric TR pricing does a priori not favour productive efficiency. In particular, even if it ensures every type of operator (efficient or not) to recover incurred costs, it imposes a constraint on more efficient operators to subsidise the relative inefficiencies of their competitors. Consequently, incentives to deal with inefficiencies may be reduced and passed on to downstream markets ...”²⁸

3.32 Against this background, Opal believes that its proposed termination rate does provide it with a strong incentive to reduce its own termination costs. In this respect, Opal highlights that the incentive for cost minimisation and productive efficiency is greatest if the price is set to be the “same” as other efficient operators rather than based on the individual costs of each network. Opal therefore submits that a termination rate equivalent to BT’s current Single Tandem rate is the most desirable from a cost minimisation perspective.

Effective Competition

3.33 Opal believes that the proposed rate will promote effective competition because the rate would:

- a. Allow Opal to charge the equivalent rate for Single Tandem as BT, which would promote effective competition based on merits and not because of any more favourable regulatory treatment; and
- b. Remove (at least partially) the market distortion arising from the current Reciprocity Agreement which produces anomalous termination rates between larger fixed operators.

Competition based on the merits

3.34 Opal argues that Ofcom needs to consider the possible competitive effects of Opal’s proposed termination rate, including any competitive distortions that could arise if Opal’s termination rate was set significantly below or above its efficient costs.

3.35 Opal submits that its entry into the telephony market has helped to ensure a competitive market from which consumers have benefited. Opal also argues that

²⁷ See paragraph 186 of T-Mobile (UK Limited) and others v Office of Communications [2008] CAT 12, 20 May 2008

http://www.catribunal.org.uk/files/Judgment_TRDs_200508.pdf

²⁸ See page 5 at http://www.erg.eu.int/doc/publications/erg_07_83_mtr_ftr_cp_12_03_08.pdf

Ofcom, in resolving this dispute, should adopt an approach that does not act as a deterrent to market entry (or a deterrent for operators already in the market).

- 3.36 Opal contends that if an operator is forced to charge a termination rate significantly lower than its costs of termination and in doing so makes a loss or earns lower profits on termination than its competitors, it could be undercut by them on retail prices. Opal is of the view that this could undermine competition to the extent that the inability to match retail prices reflects a termination charge below efficient costs, rather than competition on the merits.
- 3.37 Opal had suggested that Ofcom should therefore be mindful that setting a termination rate that is reasonably close to the efficient costs of termination, and setting the same rate for operators providing the same service, would minimise the potential for distortion of competition. According to Opal's cost analysis, Opal's actual termination rate may be different to the proposed termination rate. Opal submits that setting a termination rate above Opal's costs would advantage Opal but would avoid callers to Opal's NGN paying a higher underlying wholesale termination rate than to call BT's fixed services. According to Opal, this would not distort competition, since there would be competition 'on the merits'.
- 3.38 Conversely, Opal submits that, if Ofcom were to set Opal's termination rate based on Opal's estimated cost of termination, other fixed operators, including BT, might be able to offer retail prices that Opal could not match, not because of inferior performance but because of disparity in termination rates.
- 3.39 Opal concludes that charging a termination rate based on BT's Single Tandem termination rate would best promote competition 'on the merits' and thus support the principle of effective competition.

Removal of the anomaly caused by the Reciprocity Agreement

- 3.40 Opal believes that the Reciprocity Agreement and its underlying principles are distorting the market in that they prevent Opal from competing on a fair and reasonable basis with two other similarly sized operators, Virgin Media and Kingston Communications ("Kingston"). Opal, however, does point out that it does not compete directly with Kingston in the retail market but that there is still an impact on competition arising from a transfer of wealth from Opal to Kingston because of the differing termination rates. Table 1 shows details of current termination rates of Kingston and Virgin Media.
- 3.41 Opal believes that what is striking is that all three operators are subject to the same regulatory obligations to offer network access on fair and reasonable terms; Kingston is also subject to setting cost-orientated termination rates. However, Opal argues that the way in which the Reciprocity Agreement works in practice means that both Virgin Media and Kingston can charge a much higher termination rate.
- 3.42 Opal argues that the interconnection regime fails to deliver a consistent approach to the setting of termination rates and fails to take into account the particular challenges faced by new operators. Opal believes that as a result of this it is subsidising both Virgin Media and Kingston. Opal thinks that its proposed termination rate would go some way to restoring the competitive imbalance caused by the Reciprocity Agreement. Opal submits that the proposed rate is lower than Kingston's, reflecting economies of scale in Opal's network; it is slightly higher than Virgin Media's, which according to Opal reflects the need to recover start-up costs.

- 3.43 As far as Opal is aware, BT has never suggested that the Virgin Media or Kingston rates are unfair or unreasonable. Opal therefore concludes that BT appears to accept that these rates are fair and reasonable.
- 3.44 Opal submits that its proposed termination rate would promote effective competition based on merits and that it would remove (at least partially) the distorting effects of the current Reciprocity Agreement. As such, according to Opal, the proposed rate finds full support in the principle of effective competition.

Reciprocity

- 3.45 The principle of reciprocity provides that where services are provided reciprocally, charges should also be reciprocal. Opal submits that the proposed termination rate is reciprocal in that it reflects the conveyance of a call across one tandem and one switch in the Opal network in a manner that is identical to how a call is conveyed in BT's network.
- 3.46 Opal's view is that Opal and BT provide reciprocal services to each other, fixed geographic call termination, and the charges for this service would also be reciprocal with the introduction of the proposed termination rate for Opal. In contrast, according to Opal, the current interpretation of the Reciprocity Agreement does not allow Opal to charge a termination rate that reflects how calls are actually conveyed in its NGN.
- 3.47 Opal also argues that the proposed termination rate is consistent with the spirit of the current Reciprocity Agreement but avoids the distorting effects of the current formula for calculating termination rates [see Section 2 paragraphs 2.13 to 2.16]. Opal argues that the proposed rate is more reciprocal than the current arrangements because it reflects the identical form of conveyance in the respective networks.

Distribution of benefits

- 3.48 Opal does not consider the principle of distribution of benefits to be particularly meaningful in this case. However, Opal does argue that its proposed termination rate would be desirable from a distribution of benefits perspectives because it would allow Opal's customers to benefit from any lower costs but would avoid callers to Opal paying more than to BT.
- 3.49 According to Opal, lower termination rates, such as Opal's under the current Reciprocity Agreement, could alter this distribution of benefits. Opal argues that benefits to callers to Opal could be increased to the extent that originating operators reflect lower Opal termination rates in lower retail call prices and reducing benefits to Opal's own customers. Opal believes that this is not desirable from a distribution of benefits perspective.

Practicability

- 3.50 Opal believes that the proposed termination rate based on BT's Single Tandem rate offers the most practicable approach to setting Opal's rate, as opposed to a specific rate based on Opal's actual costs. According to Opal, there would be no need to make any detailed assessment of Opal's own costs; and using BT's costs for the basis of Opal's rate would provide certainty.

Benchmarks

3.51 Opal put forward a number of benchmarks to provide further support for its proposed termination rate. These benchmarks are:

- a. The Single Tandem termination rate charged by BT;
- b. The termination rate charged by Kingston;
- c. The termination rate charged by Virgin Media; and
- d. The IP Exchange termination rate charged by BT.

3.52 Table 1 sets out the termination rates for each of these operators, as well as Opal's proposed rate.

Single Tandem termination rate charged by BT

3.53 The termination rate proposed by Opal is equivalent to the BT Single Tandem rate set out in BT's carrier price list. Opal considers that this rate is the most relevant because it is based on the efficiently incurred costs of BT and reflects how calls are routed over a tandem and local switch (the same routing the Opal contend takes place in its NGN).

Termination rate charged by Kingston

3.54 Opal considers that the Kingston rate is relevant because it reflects the termination costs of an efficient (but smaller) UK operator which have been verified by Ofcom as part of imposing relevant SMP conditions; and it is a rate which BT has accepted to pay and therefore considers as fair and reasonable. Opal accepts that Kingston is a smaller network than Opal and therefore may not benefit from the same level of economies of scale. Opal has taken this into account by proposing a rate which is below that of Kingston.

Termination Rate charged by Virgin Media

3.55 Opal considers that the termination rate charged by Virgin Media is a relevant benchmark because its network and that of Opal are likely to be the closest in size. However, Opal notes that Virgin Media's network is still larger than Opal's and is therefore likely to benefit from larger economies of scale (and scope, because of digital television). As such, Opal argues that it is reasonable to assume that Virgin Media's termination rate should be slightly lower than that for Opal; this has been reflected in Opal's proposed rate.

IP Exchange termination rate charged by BT

3.56 Opal has drawn Ofcom's attention to BT's IP Exchange service and the fact that BT is allowed to charge other operators a Single Tandem rate for terminating calls to those numbers. Opal argues that in the absence of BT's 21CN network, the IP Exchange service is probably the closest parallel to NGN call termination that can be found in BT's current network. As such, Opal argues that the IP Exchange rate could be considered a suitable benchmark.

3.57 Opal also notes that BT charges Single Tandem rates for terminating calls to numbers that are parented on IP Exchange, arguing this further supports its argument that IP Exchange is a suitable benchmark.

BT's response

- 3.58 BT responded to Opal's submission on 16 July 2009. BT argues that Opal's proposed termination rate based on BT's Single Tandem rate is not fair and reasonable.
- 3.59 BT did not agree with Opal that there are two layers of switching in Opal's NGN. BT said that there is only one layer of switching in Opal's IP network and that further it is not possible for it to interconnect directly to Opal's ASX. BT therefore argues that only costs for interconnect at a Local Switch (DLE) are relevant.
- 3.60 BT submitted a diagram to show its own view of how a call is routed in Opal's NGN (Figure 2).

Figure 2: BT's version of Opal's IP network

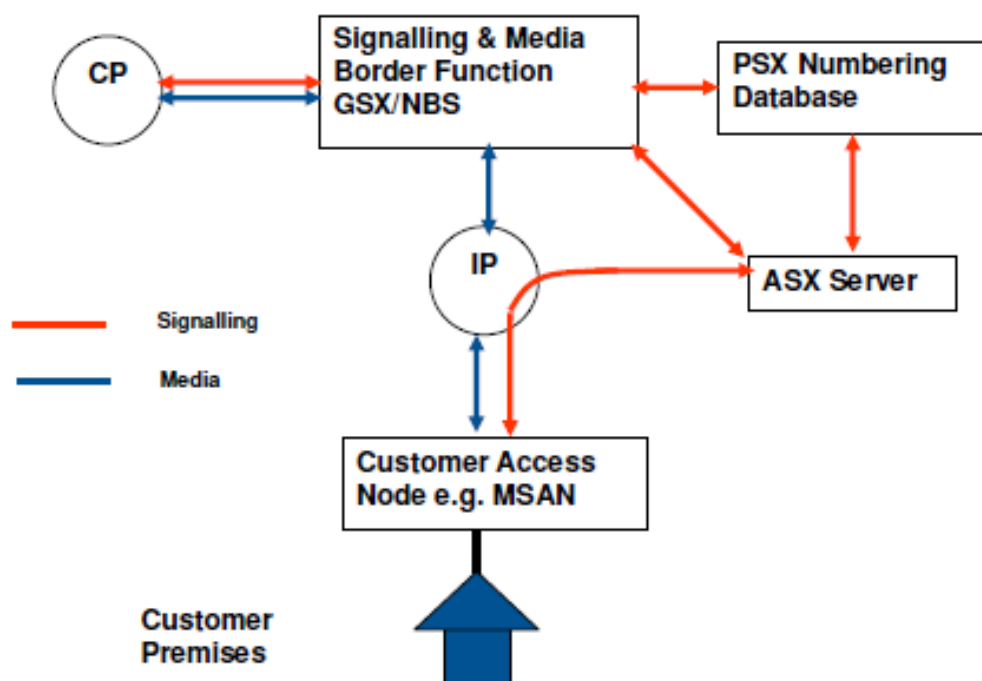

Source: BT

- 3.61 BT believes that in Opal's network the signals (speech and control, media and signalling) come in through a signalling and media border function which can be a GSX or a Network Border Switch (NBS), depending on the configuration of the box. According to BT, the termination of calls on Opal's fixed network works as follows:
- the GSX/NBS converts the signalling (IUP, ISUP or SIP) to the proprietary version of SIP used by the ASX;
 - when it receives a call the GSX/NBS queries the numbering and routing platform, in this case a Sonus PSX;
 - the PSX tells the GSX/NBS where to route the call based on the called number;
 - the signalling is sent to the ASX that controls the customer access node for the end user;

- the media is sent directly to the customer access node, as negotiated between the GSX/NBS and the ASX using proprietary SIP signalling.
- 3.62 BT concludes that there is only one level of switching in Opal's IP network and the point nearest the customer where the signals can be accessed is at the signalling and media border function (whether this is a GSX or an NBS); it is not possible to interconnect at an ASX.
- 3.63 BT also responded to Opal's suggestion that BT's IP Exchange service is probably the closest parallel to NGN call termination that can be found in BT's current network, and that it therefore provides a suitable benchmark. BT argues that this is not the case because:
- geographic numbers are not 'parented' on IP Exchange (which is a transit platform), and in the circumstances to which Opal is referring, interconnect takes place at a BT tandem switch;
 - the calls then pass through the IP Exchange platform which converts the signalling from TDM to IP, and onto the IP 'switch' of the CP which owns the end user.
- 3.64 Thus, BT contends that there are two levels of switching for which BT charges the Single Tandem termination rate. BT argues that it is open to Opal to negotiate interconnect directly with TCPs that are connected to IP exchange and to agree an appropriate termination rate.
- 3.65 BT argues that the ASX also falls outside the definition of a switch as set out in the Standard Interconnect Agreement (SIA). Annex D of the SIA defines a Local Exchange as:
- "a digital Switch ... connects by that Switch alone calls from Network Termination Points in the Operator System"; and
 - a Switch is defined as "telecommunications apparatus within a System which performs the function of switching and routing Calls".
- 3.66 BT's view is that the Opal's ASX cannot be an Operator Local Exchange because it is not a Switch, it is a call server, and cannot connect calls by that switch alone from Network Termination Points in the Operator System.
- 3.67 If the argument is accepted that it is not possible to interconnect at an ASX, BT argues that Opal cannot unilaterally require BT, or any other CP, to use IP interconnect. It submits that a new network interface such as IP interconnect would require: (i) agreed industry technical standards; (ii) testing for quality standards; (iii) an operations and provisioning manual; and (iv) a new contract to incorporate such radical changes.
- 3.68 BT also argues that any Operator Exchange requiring the use of a new interconnect interface, such as IP interconnect for direct interconnection to that Operator Exchange, cannot be considered to be an Operator Switch Connection under the Standard Interconnection Agreement unless the new interface has been properly catered for. BT considers that Opal has not sought to put in place any of the necessary commercial and technical arrangements.

BT's views on the relevance of the six principles of pricing and cost recovery

3.69 BT commented on the six principles for pricing and cost recovery. It considers that those relating to cost causation, effective competition, reciprocity and cost minimisation are relevant to this dispute and that those relating to practicability and the distribution of benefits are not.

Cost causation

3.70 BT argues that, as the first point at which BT can interconnect in Opal's network is the GSX, this equates with BT's costs of local call termination. It is BT's view that if Opal's cost of local call termination is higher than BT's because of Opal's choice of technology then it is not reasonable to pass on this additional cost to BT, as it did not cause the extra costs to be incurred.

3.71 BT also considers that it is not reasonable for Opal to cause BT to cover the costs of interworking from TDM to IP. BT notes that the approach agreed by industry for migration to NGN is that additional costs would not be imposed on one party without its agreement.

Effective competition

3.72 BT points out that every Communications Provider is deemed to have SMP for call termination to its own customers. BT draws Ofcom's attention to the 2006 dispute between BT and Telewest about geographic call termination²⁹, which states that CPs have incentives to set high call termination charges to increase their own revenue and the costs of competitors. According to BT, charges should be reciprocal because the retail customers of a lower cost operator should not subsidise those of a high cost operator through higher termination charges. BT's view is that, as Opal is proposing to charge BT more than it pays for call termination, their proposal is inconsistent with charges which support undistorted competition.

Reciprocity

3.73 BT is of the view that Opal's proposal is unfair and unreasonable because it would require BT to pay more than it receives for call termination. It argues that call termination is readily available to CPs at BT's DLEs – the point nearest to the customer where signals can be exchanged. Where BT interconnects at the point nearest to the customer where signals can be exchanged, the GSX in Opal's case, the same termination rates should apply as at BT's DLEs.

3.74 BT argues that the long-established compromise of using a volume related reciprocity formula should continue. BT is proposing to continue these arrangements for termination rates that will apply from 1 October 2009.

Cost minimisation

3.75 BT notes Ofcom's recognition that CP's have weak incentives to minimise costs and charges of call termination because the implications of higher costs are faced by the customers of competing providers. BT argues that it is fair and reasonable to assume that any operator would only invest in alternative means of terminating calls if it was going to generate an advantage in terms of lower costs or that there was, as a result of the investment, a higher revenue potential to justify the expenditure. On this basis, BT

²⁹ See footnote 27.

argues that if Opal incurs costs in excess of BT's from the point nearest to the customer where the signal can be exchanged, it is unfair and unreasonable for these to be passed on to another provider.

Information received from Opal in response to the section 191 information request

3.76 We received a response to the section 191 information request from Opal on 31 July 2009 and also met with them on 4 August 2009 to clarify some of the responses given. Opal also commented on BT's submission.

3.77 Opal's response clarified its network architecture how various elements of hardware interact. Opal explained that its NGN is based on a so-called Sonus Open Services Architecture. Opal's response also included a more detailed explanation of its Sonus equipment, the PSX, GSX and SGX, and how they interact during a call. Figure 3 sets out in diagrammatic form how Opal considers that the network is structured and how the media and signalling is routed to end users (who are connected to the MSAN).

Figure 3: Opal's view of its NGN with a GSX layer

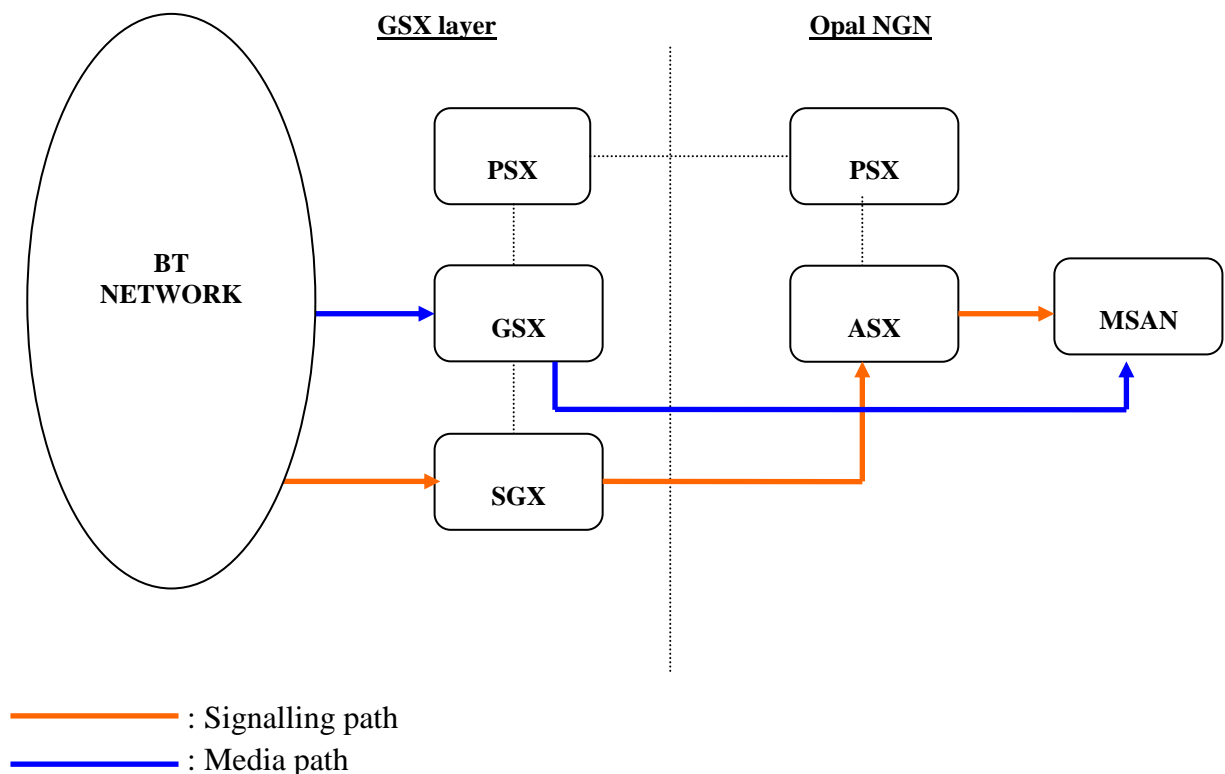

Source: Opal

3.78 Opal argues that its NGN looks very different to a conventional TDM network. According to Opal, an NGN is in essence interconnected computer hardware and software residing on computer servers which together convey packets of data to convey traditional telephony services. Opal also set out the role of each Sonus component to aid Ofcom's understanding. According to the explanation provided by Opal, these are:

- a. **SGX** – this is a piece of software whose sole purpose is to accommodate the C7 signalling used in TDM networks. It works alongside the GSX to provide interconnection between the NGN and the legacy TDM (SS7) network. It uses the standard ISUP protocol to communicate with the TDM network.
- b. **GSX** – this is a piece of separate computer hardware whose objective is to convert TDM traffic (using the ISUP protocol) to IP traffic (using a proprietary SIP protocol). Opal argues that the sole purpose of the GSX is to provide TDM interconnection capability for the Opal NGN. The GSX will identify the ASX to which the call should be routed. Together with the PSX, the GSX provides Class 4 transit functionality similar to a TDM tandem switch. The GSX will communicate with the ASX using a proprietary SIP protocol and with the PSX using a proprietary protocol called Diameter+. Opal submits that from an NGN operator's commercial perspective, the combined cost of installing and maintaining the GSX, SGX and SDH multiplexing equipment is comparable to the cost of installing and maintaining a conventional TDM tandem switch.
- c. **PSX** – this provides Intelligent Network ('IN') functionality across switching equipment whether packet (ASX) or circuit (GSX) based. The PSX receives signalling information from the call control and signalling functions located within the GSX or ASX, performs services processing (such as digit analysis, screening and blocking, number translation, two-stage dialling, and traffic control), and instructs the GSX or ASX on how to route calls.
- d. **ASX** – this is a piece of software that resides on a client/server infrastructure ([X]) that is physically separate from any other component of the Opal NGN. Each ASX is linked (or parented) to a number of MSANs in BT's local exchanges. The ASX routes the call to the MSAN for onward termination at the premises of Opal's end-customer.

3.79 Opal believes that the ASX should be considered a local switch in the Opal NGN because it is the key component in the Opal NGN that performs the function of switching and routing calls to the relevant network termination point. In addition, Opal points out that the ASX is logically and physically separate from other components in the Opal NGN and that Opal NGN would not function in the absence of the ASX, whereas the GSX is only a necessary component because of the need to convert calls from TDM to IP.

3.80 Opal stressed in its response to the information request that the ASX is not a TDM switch and that it would be inappropriate to attempt to analyse it using legacy TDM conventions. However, Opal specified that, in combination with an MSAN and PSX, the ASX provides the same functionality as a TDM local switch such as the DLE in BT's network. Opal also provided further support for its argument by pointing out that a call between different MSANs in the Opal network can be handed by one or more ASXs, without any involvement of the GSX, thus replicating the functionality provided by the DLE in BT's network that transits calls from one concentrator to another.

3.81 At a meeting between Ofcom and Opal on 4 August 2009, Opal clarified its view of the ASX and described it as a 'layer' with a suite of functionality that is equivalent to a local switch. Whilst Opal acknowledged that there are differences between its NGN and BT's TDM network, Opal considers that its network performs the same local and tandem and switching functions as the BT network. Opal used the meeting to emphasise the similarities between its ASX and BT's local switch stating that, even in the BT network, switching is a software function. Opal also noted that the main

difference is that on the BT network these functions run on specialist hardware and in the Opal network they run on ordinary computing servers.

- 3.82 Opal provided further information in response to the information request on how IP interconnection can be facilitated at its ASX switching layer. Opal explained that it uses Sonus 'Network Border Switches' ("NBS") which provides a session border controller function to manage IP interconnection. Opal stated that the IP interconnection service offered by Opal follows the commonly available international standard service descriptions as adopted by equipment vendors.
- 3.83 Figure 4 illustrates Opal's view of an IP interconnection between a third party network operator and the Opal NGN and also how the call is onward routed for termination via the MSAN. The physical link between the two networks is established via an Ethernet Edge Aggregation ('EEA') point. Opal explained that two Service Virtual Local Area Networks ('SVLANs') are constructed through the EEA to the IP address residing on the NBS; the NBS carries the signalling and the media through to the ASX with the assistance of the PSX.

Figure 4: Opal's view of IP Interconnection in the Opal NGN

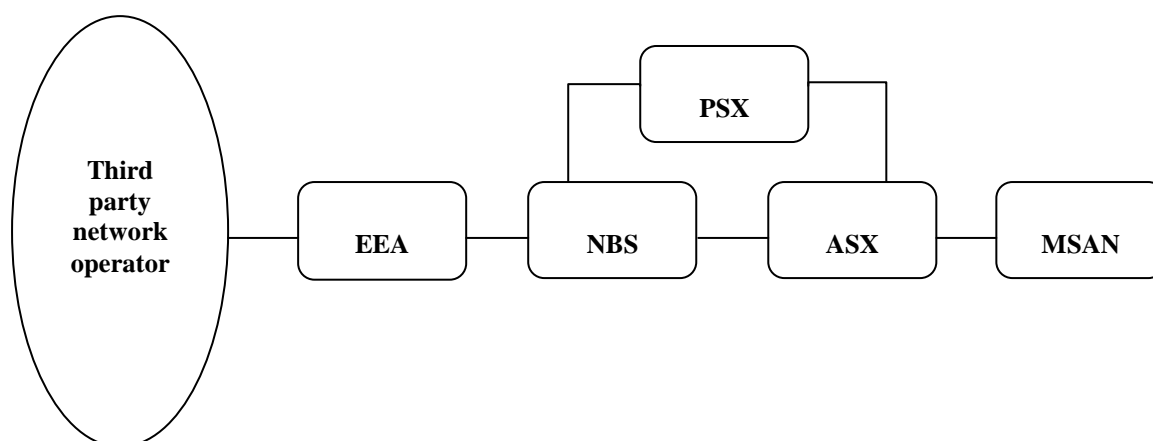

Source: Opal

- 3.84 We also sought further information on the commercial and technical discussions held between Opal and BT to facilitate interconnection directly to Opal's ASX layer. Opal explained that it has participated in the industry-wide discussions with BT under the auspices of the 21CN programme. Opal considers that the technical standards currently in place would enable BT to use IP to interconnect to Opal's NGN.
- 3.85 Our analysis of Opal's submission and its subsequent response to the information request has been set out in Section 4; we have also taken account of BT's submission in our analysis of the issue, as well as Opal's comments on it.

- 3.86 The Draft Determination³⁰ was issued for a two week consultation on 11 September. However, we met with Opal on 24 September, prior to the consultation closing, in order for them to clarify some issues raised in the Draft Determination. Responses were received from five stakeholders, BT, Opal, Cable and Wireless, COLT and one who wished to remain anonymous. A summary of the consultation responses and Ofcom's views on them are out in Section 5.
- 3.87 We also sought further information from Opal in relation to their cost modelling after the consultation had closed.

³⁰ Draft Determination to resolve Dispute between Opal Telecom and BT about Opal's Fixed Geographic Termination Rates

http://www.ofcom.org.uk/bulletins/comp_bull_index/comp_bull_ocases/open_all/cw_01027/

Section 4

Ofcom's Assessment of the Issues as set out in its Draft Determination

Explanation of this section

- 4.1 This section sets out our analysis of the matters in dispute and the provisional conclusions which we published in our Draft Determination. The text of this section is the same as that in the corresponding section of our Draft Determination. Where we refer to Ofcom's views and conclusions in this section, we are referring to the provisional views which we set out in the Draft Determination.
- 4.2 In section 5, we go on to set out the responses which we received to our Draft Determination, our consideration of those responses, and our final conclusions.

Issue to be Resolved

- 4.3 The scope of the dispute (which has been agreed by Opal and BT) is to determine whether Opal's proposal for setting charges for termination on the Opal IP network at the prevailing BT Single Tandem rate is fair and reasonable under SMP Condition BC1.
- 4.4 In line with the parties' wishes we have restricted our analysis to this question. In particular, we have not examined or proposed any alternative rates.

Assessment of 'fair and reasonable'

- 4.5 In the Review of Fixed Geographic Termination Markets in 2003³¹, Oftel said that³²
- "Condition BC1 requires charges to be 'fair and reasonable'. It does not mandate that charges should be based on BT's charges. Any PECN³³ could therefore set other charges if it believed that they were 'fair and reasonable'. But Oftel's view is that charges that were not based on BT's are unlikely to be 'fair and reasonable'. Nevertheless, the Director would need to consider any dispute on its relative merits. In any case, charges would have to be competitively neutral."
- 4.6 Based on the submissions of the parties, the key question in this case is whether call termination from Opal's GSX is analogous to Single Tandem termination from BT's network and hence whether BT's Single Tandem charge is an appropriate reciprocal charge for Opal to levy for termination on its network.
- 4.7 The assessment of fair and reasonable charges can be assisted by consideration of relevant benchmarks. Opal has put forward a number of benchmarks, which we take into account in our assessment.
- 4.8 In addition, in determining whether the charges proposed by Opal are fair and reasonable, we have considered the arguments put forward by the parties using the

³¹ Review of fixed geographic call termination markets Identification and analysis of markets, determination of market power and setting of SMP conditions: Final Explanatory Statement and Notification, 28 November 2003

³² Paragraph 4.15.

³³ Public Electronic Communications Network

six principles of pricing and cost recovery as a general framework of analysis. These were developed by Oftel in the context of number portability, endorsed by the Monopolies and Mergers Commission³⁴ and have subsequently been used by Ofcom in analysing various pricing issues³⁵.

4.9 The six principles of pricing and cost recovery were set out in detail in Section 3 paragraphs 3.22 to 3.50. They are:

- **Cost causation:** the cost should be recovered from those whose actions cause the costs to be incurred at the margin;
- **Cost minimisation:** the mechanism for cost recovery should ensure that there are strong incentives to minimise costs;
- **Effective competition:** the mechanism for cost recovery should not undermine or weaken the pressure for effective competition;
- **Reciprocity:** where services are provided reciprocally, charges should also be reciprocal;
- **Distribution of benefits:** the costs should be recovered from the beneficiaries especially where there are externalities; and
- **Practicability:** the mechanism for cost recovery needs to be practicable and relatively easy to implement.

4.10 The application of any one of these principles to the relevant circumstances can sometimes point in a different direction to the other principles. But the set of principles provides a framework to identify such trade-offs and to facilitate the use of judgement to strike an appropriate balance in reaching conclusions.

4.11 Ofcom believes that the use of these principles of pricing and cost recovery is consistent with its obligations, in particular the Community requirements under section 4 of the Act, the duties set out in Article 8 of the Framework Directive (Directive 2002/21/EC) and its general obligations under administrative law.

4.12 We have also taken into account previous statements made by Ofcom and the legacy regulators³⁶. We note that that, as discussed in section 2, the SMP obligation on the terminating CP – in this case, Opal – is that the charges are required to be ‘fair and reasonable’ and not that the charges are optimal or free of all distortions.

4.13 As set out in Section 2 paragraph 2.12 Ofcom considers that the use of reciprocal charging for call termination services can be fair and reasonable approach which

³⁴ Telephone Number Portability: A Report on a reference under s13 of the Telecommunications Act 1984 (MMC, 1995)

³⁵ See for example: ‘Determination under Section 190 of the Communications Act and Direction under Regulation 6(6) of the Telecommunications (Interconnection) regulations 1997 for resolving a dispute between Orange Personal Communications Services Ltd. (‘Orange’) and British Telecommunications plc (‘BT’) concerning the cost sharing arrangements for Customer Sited Interconnect (‘CSI’) links connection and rental charges’, 19 November 2003. See also ‘Direction concerning ADSL Broadband Access Migration Services; and a Draft Determination to resolve a dispute between Tiscali, Thus and BT concerning ADSL Broadband Access Migration Services’, 9 August 2004; Determination to resolve a dispute between BT and Telewest about geographic call termination reciprocity agreement, June 2006; Dispute between Cable and Wireless and T-Mobile about mobile termination, May 2009.

³⁶ See Ofcom’s Resolution of a dispute between BT and Telewest about reciprocal charging arrangements for call termination rates, 16 April 2004

fulfils the six principles. The question in this case is whether call termination from Opal's GSX is equivalent to Single Tandem termination on BT's network and hence whether BT's Single Tandem charge is an appropriate reciprocal charge for Opal to make for such services.

Previous statements by Ofcom and Oftel regarding network topology and reciprocity

4.14 Annex C to the 1997 Network Charging Statement³⁷ discussed Oftel's approach to the reciprocal charges for call termination on OLO³⁸ networks. This statement was issued prior to the industry developing the current methodology for reciprocal charging.

4.15 In that document, Oftel noted³⁹ that:

“OLOs tend to have a different topology to BT. For example, typically in a cable operator's network, one switch covers a catchment area larger than that covered by a BT local switch. Therefore the call termination service on OLO's network corresponds to two services on BT's network: local exchange and Single Tandem. In such circumstances, theoretically the competitively neutral position would be that the OLO would receive a mix of local exchange segment and Single Tandem rates, depending on what the composition of interconnect calls to the OLO tandem and local switches would be if, hypothetically, the OLO were to have both local and tandem switches. Since the correct charge for each call minute depends upon a counterfactual it cannot be known with accuracy”.

4.16 Later in this Annex, Oftel discussed approaches for the application of reciprocity to call termination but noted that it was for BT and industry to negotiate and agree on an approach to set other CPs' charges given a set of key objectives⁴⁰.

4.17 In 2006, Ofcom investigated whether Telewest's proposal to set charges for single switched termination on Telewest's network at the prevailing BT Single Tandem rate was fair and reasonable. In its Determination⁴¹ on this dispute, Ofcom said that BT's counter proposals, as far as Single Switch Operator (SSO) charges are concerned, broadly comply with one of the approaches to reciprocity identified by the Director General in the 1997 statement, specifying that:

“This approach involves calculating a single charge for other CPs' call termination as a weighted average of BT's local exchange segment and Single Tandem segment charges, using actual volumes of other CP to BT traffic to compute the weights. Furthermore, the approach recognises the topological differences between the networks of BT and the other CPs since call termination on other CPs' networks can be characterised as corresponding to two interconnection services on BT's network: local exchange segment and Single

³⁷ Network Charges from 1997: Annexes to the Statement Oftel July 1997

³⁸ Other Licensed Operators, i.e. networks other than BT.

³⁹ Annex C, paragraph C.12

⁴⁰ Paragraph C.31 - Oftel believed that these key objectives were: “promoting effective competition by ensuring competitive neutrality; providing operators with sound make or buy investment signals; giving strong incentives for operators to minimise costs; and choosing an approach that is practical to implement”.

⁴¹ Determination to resolve a dispute between BT and Telewest about geographic call termination reciprocity agreement – Final determination, Ofcom 16 June 2006

Tandem segment. Other CPs' call termination charges should therefore be a combination of BT's charges for these two services"⁴².

Ofcom's approach to resolving this dispute

4.18 Having taken account of representations from the parties, our duties as set out in the Act, and the principles and precedents set out above we have undertaken three main areas of work to assess Opal's proposal:

- firstly, we have investigated Opal's claim that its NGN network is analogous with the BT network for the purposes of geographic call termination and in particular that call termination on the Opal network is comparable to Single Tandem call termination on the BT network. As noted at paragraph 4.6 above, we regard this as the key issue in this dispute;
- secondly, we have considered whether the benchmarks suggested by Opal support Opal's proposed termination charges; and
- thirdly, we have considered the parties arguments based on the six principles of pricing and cost recovery.

4.19 We have then considered the extent to which our proposed outcome is consistent with our statutory duties.

A: Are the network topologies of Opal and BT analogous for the purposes of termination rates?

Opal's submission

4.20 As discussed in Section 3, Opal has argued that, for the purposes of geographic call termination, its NGN network is analogous with the BT network and in particular that call termination on its network is comparable to Single Tandem call termination on the BT network. In support of this view, in its first submission Opal notes that for the purposes of call termination on the Opal NGN network, BT is interconnected at the GSX. Opal argues that:

- the GSX is a tandem switch;
- that BT calls terminating on the Opal NGN network are switched at least twice before termination on customer lines, firstly by the GSX (which as noted above, Opal argues is a tandem switch) and secondly by the ASX which Opal argues is a local switch;
- BT could instead interconnect at the local switch layer of the Opal network using IP interconnection.

4.21 In its second submission, Opal explains that the functions of the GSX and ASX which were identified as the local and tandem switches in their first submission are not identical to those of BT's local and tandem switches due to the differences in the technology used in the respective networks. However, Opal argues that its NGN consists of two "layers" – a GSX layer and an ASX layer and that the different components of the NGN network (either individually or in conjunction with one

⁴² Paragraph 86 Determination to resolve a dispute between BT and Telewest about geographic call termination reciprocity agreement – Final determination, Ofcom 16 June 2006

another) perform the same functions as the local and tandem switches in BT's network at these two 'layers'. Opal also suggests that the GSX is only required as a network component to support TDM interconnection with other networks and that the associated costs could be avoided if BT were to use IP interconnection instead of TDM interconnection. BT would then interconnect directly at the local switch layer of the Opal NGN.

4.22 On the basis of the claimed similarity of architecture, call routing and switching, Opal argues that Single Tandem call termination on the BT network is the most relevant benchmark for call termination on the Opal NGN network.

BT's submission

4.23 As set out in paragraph 3.59 of Section 3, BT argues that there is in fact only one layer of switching within the Opal network. BT also claims that it is unable to connect directly to Opal's ASX, as this is a call server and not a switch and that therefore only costs for interconnect at DLEs are relevant (i.e. on BT's network, corresponding to the local exchange segment rate).

Ofcom's provisional view on the question of network analogy

4.24 As previously discussed, the Opal NGN network is a so-called Next Generation Network (NGN). NGNs use Internet protocol to carry and switch calls rather than the more conventional Time Division Multiplex ('TDM') technology that is used by BT and which is in widespread use in the current generation of telephone networks. The architecture of the Opal NGN therefore differs significantly from that of the BT network.

4.25 Figures 5 and 6 below show Ofcom's view of the architecture of the Opal NGN and the BT network.

Figure 5: Ofcom view of Opal NGN Network Architecture

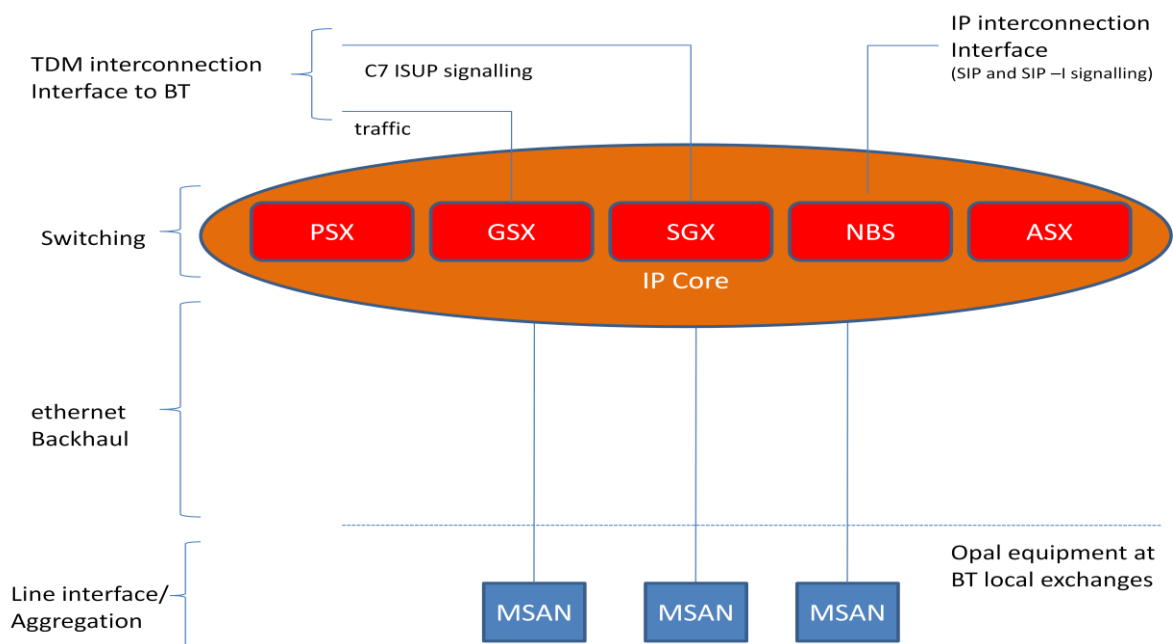

Source: Ofcom

Figure 6 - Ofcom view of the BT Network

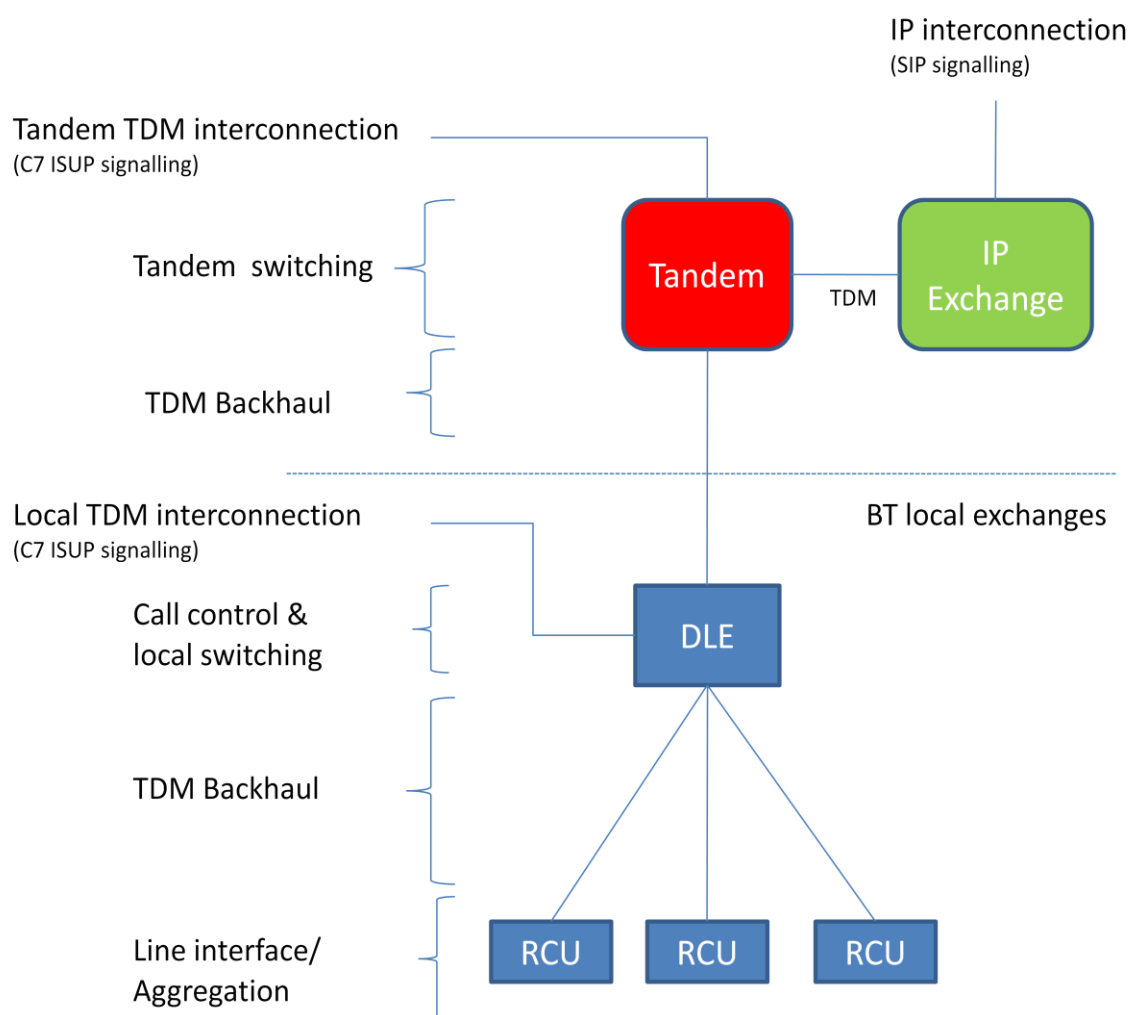

Source: Ofcom

Overview of the BT network

- 4.23 In the BT network, customer lines are connected to Remote Concentrator Units ('RCUs'). RCUs provide the network line interface functions for telephone services (dial-tone and ringing etc) and aggregate traffic for transmission to Digital Local Exchange ('DLE').
- 4.24 The DLE is the local switch component in BT's network providing own-exchange switching (i.e. switching calls to lines on other RCUs subtended to the DLE) and switching traffic to adjacent DLEs and to the tandem switch layer. DLEs are normally located in major local exchange buildings and are generally co-located with at least one RCU, and serve a group of remotely located RCUs in the local area. DLEs also support interconnection with communications providers for call termination on lines connected to RCUs that are subtended to the DLE.
- 4.25 The BT network also has a second or tandem switching layer. Tandem exchanges are directly interconnected to DLEs in their region and also to other tandem exchanges. DLEs route all calls to lines that are not connected to their RCUs, or to

adjacent directly-connected DLEs, to a tandem exchange where depending on the called number calls are either routed to another DLE for termination or to another tandem exchange which is directly connected to the relevant DLE.

Overview of the Opal NGN Network

- 4.26 In the Opal NGN network, customer lines are connected to Multi Service Access Nodes ('MSAN'). MSANs provide the network line interface functions for telephone and broadband services and aggregate traffic for transmission to IP Core Network.
- 4.27 For voice services MSANs perform a very similar function to the RCU in BT's TDM network. The MSANs are located in each of the BT exchanges at which Opal provides services with LLU⁴³.
- 4.28 In contrast to the BT TDM network, traffic is not switched at major local exchange sites. Instead traffic (including own-exchange traffic) is carried over lengthy ethernet backhaul links for switching in the IP Core Network.
- 4.29 The IP Core Network is a high capacity IP network that is used to carry and switch both broadband and voice services. IP traffic is switched only in this part of the network using high capacity IP routers. Most of the core network components in the Opal network (included the ASX, PSX, NBS, GSX and SGX described below) are directly attached to the IP Core Network and are located at Opal's [X] central sites.
- 4.30 A key difference between the Opal NGN and the BT TDM network is that in the Opal NGN the telephony call control function is separated from the switching functions of the network.
- 4.31 The ASX call servers provide the primary call control and signalling functions for voice services. They are responsible for call setup and clear-down and also support ancillary telephony services such as three-way calling etc.
- 4.32 ASXs interact with the PSXs (see description below) which provide call routing and other ancillary call control functions necessary for voice calls.
- 4.33 The ASXs together with the PSXs are approximately analogous with call control function performed by the DLE in BT's TDM network. However the DLE also provides a traffic switching function whereas the ASX is purely a signalling and control function.
- 4.34 PSXs provide the services and routing support functions in the Opal NGN including dialled digit analysis, screening and blocking, number translation, two-stage dialling and traffic control. They also instruct the ASXs and GSX/SGX on how to route calls.
- 4.35 The GSX gateway controllers and the SGX signalling gateways collectively provide the TDM interconnection functionality for the Opal NGN. The GSX carries the traffic and provides IP to TDM interworking (i.e. protocol conversion). The SGX handles the TDM signalling for the GSX traffic. The GSX incorporates a call control function.
- 4.36 The NBS provides the network border control functionality required for IP interconnection with other networks. For voice services it provides border security

⁴³ Local Loop Unbundling (LLU) enables operators to connect directly to the consumer via BT's copper local loops and then add their own equipment to offer broadband and other services. This process involves operators accessing BT's local exchange buildings to connect to BT's network of copper lines which connect them to homes and businesses.

(firewall), traffic handling and signalling functions. It supports the SIP and SIP-I IP voice signalling protocols.

Ofcom's provisional view on the question of the network analogy

- 4.37 We have analysed the networks of Opal and BT to understand whether the way in which calls are routed and switched on their respective networks can be considered analogous.
- 4.38 Our fundamental concern about the network analogy advocated by Opal is that as discussed above, there are very significant differences in the network technologies and architectures of the BT network and the Opal NGN network. We consider that these differences make it difficult to make direct comparisons between the functions of components in the BT and Opal NGN networks in the manner suggested by Opal.
- 4.39 To the extent that such a comparison can be made, we consider that the Opal network is not strongly analogous with the BT network in the manner suggested by Opal. There are several reasons for this view:
- In the BT network, there are two clearly distinct switching functions (the local switch and the tandem switch) whereas in the Opal NGN network all switching and call control functions are centralised in the IP Core Network and in components directly attached to the IP Core Network. In our view it can be argued that there is a single switching layer in the Opal NGN rather than two as suggested by Opal;
 - In our view, the ASX is a call control functions that resides at the IP Core Network and is not a switching function that resides at a lower layer of the network than the GSX as argued by Opal. It is not possible for other Communications Providers to connect directly to the ASX as suggested by Opal in its first submission. As noted above (paragraph 4.36), IP interconnection is via the NBS;
 - Opal argues that IP interconnection is at a lower layer in the Opal NGN network than TDM interconnection at the GSX/SGX. Given that the GSX, SGX and NBS are components that are directly connected to the IP Core Network, in our view a better characterisation of Opal's network is that both IP and TDM interconnection are at the same network layer and simply require different interface nodes to accommodate the different types of traffic. We also note that the GSX and NBS share common hardware components and that the GSX can also perform an NBS function. In our view this lends further weight to the view that IP and TDM interconnection are not at different switching layers in the Opal NGN Network.

Ofcom's provisional conclusions on network analogy

- 4.40 We therefore do not accept the network analogy on which Opal has relied in this dispute. Our comparison of the Opal and BT networks does not support the view that interconnection with the Opal network at the GSX is equivalent to Single Tandem interconnection with the BT network for the purposes of geographic call termination. In our view a better characterisation of Opal's network is that both IP and TDM interconnection are at the same network layer and simply require different interface nodes to accommodate the different types of traffic.
- 4.41 One interpretation of BT's argument is that because the GSX is "the point nearest to the customer where signals can be exchanged in the Opal IP Network", it should be

BT's DLE rate which applies, as opposed to the weighted average derived from the current Reciprocity Agreement. Our comparison of the Opal and BT networks does not support such an argument, given the differences in architecture and topology of the Opal network and, in particular, the centralisation of the switching and interconnection functions in the Opal network. To the extent that any comparison between Opal's and BT's networks can be made, we consider that GSX interconnection on Opal's network is better characterised as corresponding to two interconnection services on BT's network - local exchange segment and Single Tandem – than to local exchange segment alone. In the past we have found that the Reciprocity Agreement is one way of arriving at a fair and reasonable termination rate taking into account the mix of services provided. However, due to changing circumstances, such as the introduction of NGNs, other ways of arriving at rates might additionally or alternatively be fair and reasonable. We note that BT and the industry are negotiating a revised Reciprocity Agreement to replace the existing one which expired on 30 September 2009.

B: Benchmarks:

- 4.42 As previously discussed in Section 3 in paragraphs 3.53 to 3.57, Opal has identified four benchmarks for its proposed geographic call termination rates, namely:
- BT's Single Tandem geographic call termination service. Opal argues that this is the most relevant benchmark;
 - KCOM's local exchange geographic call termination service for the Hull area;
 - Virgin Media's local exchange geographic call termination service for the former NTL network; and
 - BT's IP Exchange service.
- 4.43 Table 3 below summarises the benchmark termination rates, as well as Opal's current and proposed termination rates. This should be referred to during the following discussion of benchmarks.

Table 3: Opal's current and proposed rates, and other benchmark termination rates

Operator	Daytime ppm	Evening ppm	Weekend ppm
Opal's Current and Proposed Termination Rates			
Opal's termination rate under the current Reciprocity Agreement	0.2592	0.1187	0.0935
Opal's Proposed rate	0.3575	0.1637	0.1289
Benchmark Termination Rates Proposed by Opal			
BT Single Tandem	0.3575	0.1637	0.1289
Kingston (Hull Area)	0.4135	0.1893	0.1491
Virgin Media	0.3049	0.1396	0.1099
BT IP Exchange	0.3575	0.1637	0.1289
Benchmark identified by Ofcom			
Affinity (rates effective from 1 April 2009)	0.261	0.1195	0.0941

4.44 We consider each of these benchmarks in turn below.

BT Single Tandem rate

Opal's view

4.45 Opal argues that the BT Single Tandem geographic call termination charge is highly relevant given:

- the similarity of the Opal and BT network for the purposes of call termination (as discussed in more detail above; and
- that BT is the largest UK communications provider and that Ofcom has previously concluded that these rates reflect efficiently incurred costs.

Ofcom's provisional view

4.46 For the reasons discussed in paragraphs 4.37 to 4.41 above, we do not consider that termination at BT's Single Tandem layer is a good benchmark for geographic call termination on the Opal network.

Kingston Communications in the Hull Area

Opal's view

- 4.47 Opal argues that the Kingston Communication termination rates for its Hull area network are a relevant benchmark because:
- "It reflects the termination costs of an efficient (but smaller) UK operator which have been verified by Ofcom as part of imposing relevant SMP conditions";
 - "It is a termination rate which BT has accepted to pay and therefore commercially regards as fair and reasonable and not too high to prevent BT from meeting its separate end to end connectivity obligations as imposed by Ofcom";
- 4.48 Opal also said that it accepted that "Kingston was a smaller network than Opal and therefore may not benefit from the same level of economies to scale. Opal has duly taken this fact into account by proposing a termination rate that is significantly below Kingston's termination rate".

Ofcom's provisional view

- 4.49 As outlined in paragraph 2.8 of Section 2, Kingston Communications is required to provide call termination on fair and reasonable terms, in relation to its Hull area network, Kingston is also required to set its charges on the basis of its forward looking long run incremental costs. Therefore, its obligations differ to those of other communications providers and we understand that it is not part of the Reciprocity Agreement.
- 4.50 In 2001 in its Direction in relation to a dispute between BT and Kingston Communications⁴⁴ Oftel noted that Kingston "is in a unique position in that it is the only other UK fixed network operator with SMP, and it does not compete with BT in its own area, thus nullifying the potential effects on competition of the call termination externality resulting from the fact that the caller, rather than the called person, pays for the call termination charge".
- 4.51 In the 2001 Direction Oftel considered specific evidence on Kingston Communications' costs of termination in the Hull area and determined the cost orientated termination rates accordingly. Since 2001, the charges for terminating calls on Kingston's Hull area network have fallen⁴⁵, and have fallen to a slightly greater degree than those of BT.
- 4.52 Unlike Kingston Communications, Opal has not relied on evidence on its own costs to support its proposed termination rate (we assess below Opal's claim that its cost evidence provides a useful sense check). Together with the different applicable circumstances and obligations, this limits the extent to which the termination rates for

⁴⁴ Direction under the provisions of Regulation 6(6) of the Telecommunications (interconnection) Regulations 1997 of a dispute between British Telecommunications PLC ('BT') and Kingston Communications (Hull) PLC ('Kingston') 22 October 2001

⁴⁵ We have compared the change over time of BT's Single Tandem termination charge to Kingston's termination charge. We took Kingston's termination charge (as mandated by Oftel in its direction) which had the effective date of 1st April 2000 to 31st March 2001 and Kingston's current termination charge, as outlined in Opal's submission, and calculated the percentage change in each time of day rate (reductions of 39%, 50% and 53% respectively for Daytime, Evening and Weekend charges). We then examined the BT Single Tandem termination charges over the same period and calculated the percentage change in each time of day rate (reductions of 34%, 46% and 49% respectively). Kingston's termination rates fell by a larger percentage than BT's termination rates over the same period.

Kingston Communications in the Hull area provide evidence to support Opal's proposed rates.

4.53 Finally, we note that Kingston Communications has a national network called Affinity, which is not subject to the cost orientation requirements imposed upon Kingston's Hull network, but is regulated according to the fair and reasonable requirements, and is part of the Reciprocity Agreement. Affinity's termination rates are somewhat lower than those of Kingston's Hull area network and below BT's Single Tandem rate (Table 3 above):

4.54 To summarise, we do not consider that termination rates for Kingston Communications' Hull area network provide a benchmark that clearly supports Opal's proposed termination rates. Kingston's Hull network has a unique position in the UK in relation to the termination externality. It is regulated on a different basis to other CPs and its Hull area termination rates are supported by evidence on its own costs, rather than those of BT.

Virgin Media

Opal's view

4.55 Opal argues that the Virgin Media termination rate is also a relevant benchmark. This is because:

- The Virgin Media network is likely to be closest in size to Opal's network.
- However, Opal recognises that the Virgin Media network is larger than the Opal network and may benefit for additional economies of scale and scope since the Virgin Media network is also used to deliver TV services.
- On this basis, Opal argues that it would be reasonable to assume that Virgin Media's termination costs are lower than Opal's. Opal says that it has taken this into account by setting its proposed termination rate slightly higher than that of Virgin Media.

Ofcom's provisional view

4.56 Under the current industry reciprocity arrangements, communications providers receive differing rates for geographic call termination depending on various factors, including the architecture of CPs networks and the blend of local exchange and Single Tandem call termination for calls to the BT network from CPs networks.

4.57 These factors are likely to differ between the Virgin Media and Opal networks. Hence, there are limitations on the extent to which other CPs' (in this case Virgin Media) termination rates under the Reciprocity Arrangements provide compelling evidence to support Opal's proposed rates.

4.58 Further, whilst Opal asserts that, for a variety of reasons, it would be reasonable to assume that Virgin Media's termination costs are lower than Opal's, it has not provided specific evidence to support this contention. There are factors other than the aggregate size of the operator that are likely to influence costs, including the features of the specific geographical areas served, the density of traffic, technology, the network design etc. Hence the relationship between aggregate size and termination cost may not be straightforward. Given this, in the absence of specific evidence, and in the limited time available, we have not been able to reach a clear conclusion on whether Opal's costs are higher or lower than Virgin Media's.

- 4.59 Finally we note that Virgin Media's rates are below the BT Single Tandem rate. As such, we do not believe that this rate provides compelling evidence that the Opal termination rate should be equivalent to the BT tandem rate.

Start up costs and Virgin and Kingston Communications

- 4.60 Opal also notes that Virgin and Kingston have been in the market for much longer than Opal. Their respective network investments were made a long time ago while Opal is still very much in a start up phase having launched its next generation network only two years ago. Opal suggests that their cost of terminating calls to fixed geographic numbers should therefore be much lower than Opal's either because of economies of scale (discussed above) or because they have already recovered their initial start up costs.
- 4.61 In the context of using cost information to inform the assessment of regulated prices, we do not consider that the timing of start-up costs should necessarily be regarded as causing a difference in underlying economic costs. In general we consider that start up costs should be recovered over the whole period that they provide benefits to the operator. Alternative accounting arrangements (for instance, those which recover capital costs only in the early years of life of a capital investment) provide a potential source of distortion to costs which mean that accounting costs may not properly reflect underlying economic costs.

IP Exchange

- 4.62 The BT IP Exchange service is an IP interconnection service provided by BT. IP Exchange provides interconnection with the BT TDM network including an IP to TDM interworking function. Communications providers that use the IP Exchange Service are able to send calls to BT over an IP interconnection for termination on the BT network and transit to other networks to which BT is interconnected. They are also able to receive calls over an IP interconnection from BT (and BT's transit partners) for termination on their networks.

Opal's view

- 4.63 Opal argues that the BT IP Exchange service is probably the closest parallel to NGN call termination that can be found on the BT network and should therefore be considered as a suitable benchmark. Opal notes that BT charges Single Tandem rates for call termination on its network via the IP Exchange Service and refuses handover at the local switch level.

Ofcom's provisional view

- 4.64 On the basis of Opal's submission that its network is closely analogous with the BT network for call termination (i.e. that it has two switching layers and that interconnection for call termination is at the tandem layer) then IP Exchange might be considered to provide a relevant benchmark as IP Exchange provides interconnection with the tandem layer of BT's network and also an interworking function (i.e. IP to TDM protocol conversion). However, as discussed above, we do not consider that termination from the GSX over the Opal NGN network and Single Tandem termination from BT's network are closely analogous and we therefore consider that IP Exchange does not provide a benchmark that supports Opal's proposed termination rates.

- 4.65 Opal has also argued that BT's Single Tandem call termination charges for numbers parented on IP Exchange further support its view that IP Exchange is an appropriate benchmark. We note that in its response to the Opal submission BT has indicated that IP Exchange provides a transit service for numbers on IP networks that use IP Exchange and does not directly parent (i.e. terminate) calls to any numbers.

Other potential benchmarks

- 4.66 We also considered whether there were any other benchmarks which could be useful in this case. There are numerous other telecommunications companies in the UK and, as discussed above in paragraph 4.56 in relation to Virgin Media, their termination rates will be the result of the individual application of the current reciprocity agreement to these different networks. We therefore did not consider them in any detail.

C: The six principles of pricing and cost recovery

Cost causation

Rationale:

- 4.67 The cost causation principle maintains that costs should be recovered from those whose actions cause them to be incurred at the margin. The costs of terminating a call are caused by the network originating the call, hence BT (as either originator of the call or transit operator) should pay a termination charge to Opal. Charges which reflect the efficient level of costs incurred when a call is terminated are likely to be consistent with cost causation.

Submissions by the parties

Opal's view

- 4.68 Opal says that its proposal is consistent with the principle of cost causation because the charges reflect the efficiently incurred costs of termination on the Opal NGN network, as they are based on BT's termination charges for a comparable termination service on the basis of the network analogy previously discussed.
- 4.69 Opal also argues that by using TDM interconnection to the Opal NGN network, BT is causing Opal to incur the additional cost of converting TDM to IP, thereby creating the need for a 'tandem layer' in the Opal NGN network. Opal argues these costs could be avoided if BT were to use IP interconnection to interconnect with the 'local switch' layer of the Opal network. Opal claims that if BT were to use IP interconnection at the local switch layer, Opal would reduce its interconnection costs and would be able to offer BT lower termination rates.
- 4.70 Opal has also drawn our attention to BT's IP Exchange. Opal submits that BT charges CPs sending traffic to IP Exchange customers a Single Tandem termination rate and actually refuses handover at local switch level.

BT's view

- 4.71 In its submission, BT noted that as "the first point at which BT can interconnect in Opal's network is the GSX, this equates to BT's costs of local call termination. If Opal's cost of local call termination is higher than BT's because of Opal's choice of technology then it is not reasonable to pass on this additional cost to BT as BT did

not cause the extra costs to be incurred". In a set of slides provided to Ofcom, BT noted that it was not possible to interconnect with the ASX as this must be used in conjunction with either a GSX or a Network Border Switch.

- 4.72 BT also said that it did not believe that it was reasonable for BT to be required to convert signalling to SIP (whether SIP (I) or the proprietary SIP used in Opal's network) and that BT had agreed with industry that extra costs would not be imposed on other parties as a result of BT's migration to 21CN. BT suggested that "Consistent with the spirit of reciprocity, this agreement should be applied to Opal".

Ofcom provisional view

- 4.73 Ofcom considers that it is not a matter of dispute that BT should pay a termination charge to Opal or that Opal's termination charges should be based on BT's interconnection rates. The question is whether the BT Single Tandem rate would fulfil the cost causation principle and whether this would represent the efficient level of costs.
- 4.74 As discussed above in paragraphs 4.37 to 4.41 we consider that Single Tandem call termination on the BT network is not a good analogy for geographic call termination at the GSX on Opal's NGN network. Therefore, in our view, Opal has not demonstrated that its proposal is supported by the principle of cost causation.
- 4.75 Opal's suggestion that IP interconnection at the ASX (using a NBS) would be less costly than TDM interconnection may provide a rationale for a differential in its respective charges for TDM and IP interconnection. But it does not establish that the BT Single Tandem rate is appropriate for TDM interconnection at the GSX. We have considered this issue in paragraph 4.41 above.
- 4.76 We have dealt with the issue of IP Exchange within our discussion of benchmarks in paragraphs 5.64 and 5.65 above.

Modelling the costs of Opal's network

- 4.77 In an attachment to its main submission Opal provided estimates of its costs, using a cost model which it claimed uses the same accounting and cost allocation principles as Ofcom does when setting BT's network charge controls. Opal said that this data allowed it to be satisfied that the proposed charge was cost orientated as it was between the cost floor and cost ceiling. However, Opal also noted that "it was not the objective of the cost model to determine Opal's cost of termination with any exact degree of accuracy precisely because Opal has used BT's costs as the basis for the proposed termination rate in line with Ofcom's recommended approach".
- 4.78 Opal suggested that its cost model uses fully allocated costs (FAC) and current cost accounting (CCA) as the cost standard, which it believes is an appropriate proxy for Ofcom's preferred method of forward looking LRIC+, i.e. LRIC plus a mark-up for common costs (usually, equal proportional mark-up). The cost information which Opal reported relates not to LRIC+ itself, but to the lower and upper bounds of a cost floor and a cost ceiling. The cost floor only includes the incremental cost of the voice service. The cost ceiling is the stand-alone cost of voice, i.e. the cost if Opal's network only provided voice services and provided no data services. As such the ceiling includes all of the common costs between voice and data (and not just a proportion as in LRIC+).

- 4.79 Specifically, Opal reported the CCA cost floor of [x]ppm and CCA cost ceiling of [x]ppm for quarter 1 2009 for the service in the model called “TDM to LLU different node”. Opal’s proposed termination charge is 0.23ppm (on average across times of day). On the basis of this analysis of costs, Opal claimed that its cost model is “valuable as a “sense-check” in that it confirms that the proposed termination rate is indeed well within the floor and ceiling of Opal’s estimated cost of termination”.

Ofcom’s provisional view

- 4.80 Opal provided us with a spreadsheet of its full cost model. In the limited time available we have not verified the costing methodology, the accuracy of the cost inputs, or the model’s algorithms. We have taken the model as submitted to us by Opal without any adjustments and considered whether this evidence (even if it were appropriately derived) supports Opal’s claim.
- 4.81 We note that the cost floor and ceiling reported by Opal are for Q1 2009. Opal’s model derives cost estimates by quarter for the period Q4 2007 to Q3 2022. The CCA cost ceiling is at its highest level in [x]. In subsequent quarters the CCA cost ceiling falls significantly, e.g. to [x]ppm in [x].
- 4.82 We suspect that the behaviour of the CCA cost ceiling in the early years of Opal’s model reflects an accounting distortion of a relatively immature network and so may not accurately reflect underlying economic costs, suitable to be used as a basis for charges. Opal’s model is also capable of deriving cost estimates using economic depreciation⁴⁶ which is less likely to suffer from this accounting distortion. Diagram 1 shows the CCA cost floor and ceiling, as reported by Opal, but also the corresponding figures for all other periods in Opal’s model, as well as the cost floor and ceiling using economic depreciation and, for comparison, Opal’s current and proposed termination charges. Based on our current (albeit limited) understanding of this cost evidence, we consider it likely that the economic depreciation ceiling provides a better cost estimate for 2009 than the CCA ceiling.
- 4.83 The economic depreciation cost ceiling in Opal’s model for Q1 2009 is [x]ppm, significantly lower than the CCA cost ceiling and only [x]% higher than Opal’s proposed charge. The downward trend in costs means that the ceiling falls below Opal’s proposed charge on an economic depreciation basis in [x] (and on a CCA basis in [x]).

⁴⁶ We understand that the methodology for economic depreciation in Opal’s cost model is an annuity per unit of output with a tilt to reflect changes in modern equivalent asset prices.

Diagram 1: Cost floors and ceilings – TDM to LLU different node [redacted]

- 4.84 A further point is that Opal has reported the costs of the service “TDM to LLU different node”. The model includes another service “TDM to LLU same node”, which has costs that are about [redacted]ppm lower. We understand that the most representative cost of termination would be a weighted average of the cost of these two services, which would be lower than the cost reported. Using the weights suggested to us by Opal ([redacted]% same node, [redacted]% different node), the economic depreciation cost ceiling in Q1 2009 is lower than Opal’s proposed charge (at [redacted]ppm, [redacted]% below the proposed charge).
- 4.85 Taking the above discussion into account, we do not consider that the cost evidence provided by Opal supports its claim that the proposed termination rate is “well within the floor and ceiling” of Opal’s cost of termination.

Cost minimisation

Rationale:

- 4.86 This principle implies that termination charges should be set so as to encourage efficiency and cost minimisation on the part of the terminating operator. Ofcom considers that by divorcing CPs’ call termination charges from a measurement of their costs and using instead BT’s charges, they are given strong incentives to minimise costs. Where CPs are more efficient than BT, they are rewarded through greater profit margins, which provide the incentive to achieve greater productive efficiency.
- 4.87 Furthermore, BT’s position as the largest and only ubiquitous operator offers an appropriate benchmark for the efficient operator. The use of benchmark charges that are set by reference to the efficient level of costs can be used in order to ensure that prices reflect efficient costs.

Submissions by the parties

Opal’s view

- 4.88 Opal argues that its proposed termination rate provides it with strong incentives to reduce its own termination costs and that the incentive is greatest if the price is set to be the same as other efficient operators.

BT’s view

- 4.89 In its slides BT said that “BT’s regulated call termination charges are the natural benchmark for an efficient operator”. In its submission BT argued that if Opal incur costs in excess of BT’s from the point nearest the customer where signals can be exchanged, it is unfair and unreasonable for them to pass this on to other CPs, including BT.

Ofcom’s provisional view

- 4.90 Opal’s proposal would divorce its termination rate from the costs it actually incurred and, as such, would provide good incentives for cost minimisation. However, this is also a feature of Opal’s current termination rate and alternative interpretations of

reciprocal arrangements that set Opal's termination rate by reference to BT's interconnection charges. Therefore, in our view, the principle of cost minimisation does not clearly support Opal's proposed rate over alternative rates.

Effective competition

Rationale:

- 4.91 This principle requires that charges imposed should not undermine the pressure for effective competition (whether competition between those already in the market place or competition via entry by efficient operators). The implications for termination charges were discussed in some detail in the Telewest⁴⁷ dispute.
- 4.92 The Telewest dispute described how the imposition of a termination charge on an incurred cost basis might reduce effective competition at the retail level due to the externality arising in fixed geographic call termination. This externality arises because the costs of termination are faced by those who call a network rather than the network's own customers. Hence, if the costs of termination are high and termination charges reflect incurred costs, the termination charge would be high. An inefficient network could therefore pass on its higher costs to another network – potentially improving the ability of the inefficient network to compete at the retail level. Therefore Ofcom considers that if all termination charges were based on incurred costs there would be a distortion of competition. Reciprocal charges based on BT's costs (given that BT is the largest network and its costs are regularly assessed by Ofcom) remove this distortion to competition and ensure competitive neutrality.

Submissions by the parties

Opal's view

- 4.93 Opal argues that the current Reciprocity Agreement and its underlying principles are distorting the market and prevent them from competing on a fair and reasonable basis with Kingston Communications and Virgin Media. Opal's proposed rate is lower than Kingston's to reflect the larger economies of scale in the Opal network and higher than Virgin Media's rate to reflect the fact that Opal is still in the start-up period.
- 4.94 Opal suggests that the BT Single Tandem termination rate would allow competition on the merits and that Ofcom should not adopt an approach which deters entry. Opal suggest that in general setting a termination charge close to the efficient cost of termination and setting the same rate for operators providing the same service would minimise the potential for distorting competition. Opal also suggest that the proposed rate would result in the removal (at least partially) of the market distortion created from the current Reciprocity Agreement which produces anomalous termination rates between larger fixed operators.

BT's view

- 4.95 BT notes that each operator has SMP in termination and has an incentive to set high call termination charges to increase revenues and competitors' costs. BT refers to the Telewest dispute, arguing that retail customers of a lower cost operator should not subsidise those of a higher cost operator through higher termination charges. BT

⁴⁷ See paragraphs 69 to 76 Determination to resolve a dispute between BT and Telewest about geographic call termination reciprocity agreement – Final determination 16 June 2006

considers that Opal's proposal is inconsistent with charges which support undistorted competition because it exceeds the termination rate that BT receives from Opal.

Ofcom's provisional view

- 4.96 The principle of effective competition suggests that CPs' termination rates should not be based on their incurred costs, but rather on a reciprocal basis with BT's regulated charges. Ofcom also considers that appropriately derived reciprocal termination charges provide the correct signals for efficient entry.
- 4.97 Hence once again the issue is whether the rate proposed by Opal is reciprocal. As discussed in paragraphs 4.37 to 4.41, we consider that Single Tandem call termination on the BT network is not a good benchmark for geographic call termination at the GSX on the Opal NGN network. Therefore, in our view, Opal has not demonstrated that its proposal is supported over alternatives by the principle of effective competition.
- 4.98 Given our view on the network analogy we do not consider that the Single Tandem rate would provide for competitive neutrality in the market place. Further, the limited evidence on costs (see the discussion above under Benchmarks and Cost causation) means that we do not have compelling evidence that Opal's proposed rates would appropriately reflect cost differences and best promote competition on the merits, including as between Opal, Kingston Communications and Virgin Media, as Opal argues. We also note that under its previous termination rates, which have generally⁴⁸ been lower than the BT Single Tandem rate. Opal itself suggests (see its website) that it has become the second largest voice carrier in the UK and that as Talk Talk (its landline brand), it has grown its subscriber base to 3 million customers. Opal also suggests that since the launch of CPS, Opal has gained 25% of market share, and is responsible for 34% of all new connections.
- 4.99 We have dealt with the issue of start-up costs and economies of scale in the discussion of benchmarks at paragraph 4.60 and 4.61 above.

Reciprocity

Rationale:

- 4.100 Ofcom has supported the principle of reciprocal charging for CPs' call termination charges. This principle requires that CPs' charges are calculated on a reciprocal basis to BT's own interconnection charges, taking into account the different network topologies. BT's own charges are regulated under the Network Charge Controls. The aim of reciprocity is to ensure competitive neutrality between BT and other CPs and to remove the distortive effects of the call termination externality.

Submissions by the parties

Opal's view

- 4.101 Opal states that its proposed termination charge is reciprocal i.e. it reflects the conveyance of a call across one tandem and one local switch in a manner identical to how a call is conveyed over BT's network. It suggests that the current Reciprocity Agreement distorts charging in a way that is not fair and reasonable to Opal as a next

⁴⁸ The exception is the period April to November 2008, when Opal had MSO status under the Reciprocity Agreement.

generation operator and its proposed rate is “more reciprocal” than the rate which would result from the current agreement.

BT’s view

4.102 BT argues that Opal’s proposal is “unfair and unreasonable because it requires BT to pay more than it receives for call termination”. BT also suggests that the long established compromise is that the X ratio is used in the reciprocity formula. This is a volume weighted average of what the CP pays BT for Single Tandem termination and local exchange segment⁴⁹. BT is proposing to continue this compromise.

Ofcom’s provisional view

4.103 In principle, reciprocal charging (as outlined in the 1997 Statement) refers to a family of possible arrangements, with the distinguishing feature that other CPs’ termination rates are set by reference to BT’s interconnection charges. In this sense, both the current Reciprocity Agreement and Opal’s proposal are examples of reciprocal charging. However, this is not to say that all reciprocal charging arrangements within the family of possibilities are necessarily fair and reasonable. Opal’s key argument in support of its proposal is the network analogy. However, as discussed above, we consider that Single Tandem call termination on the BT network is not a good benchmark for geographic call termination on the Opal NGN network. Therefore, in our view, the principle of reciprocity does not support Opal’s proposed rate.

4.104 As to BT’s arguments, our conclusion does not rely on the feature that under Opal’s proposed rate BT would pay more to Opal for termination than it receives. It is beyond the scope of this dispute to consider whether alternatives to Opal’s proposed rate are fair and reasonable.

Distribution of benefits

Rationale:

4.105 A key focus of this principle is to ensure that all benefits, including positive externalities, are taken into account. It also asks how the benefits of the changed charges are distributed i.e. to the firm terminating the call, the firm originating the call, and to their respective customers.

Opal’s view

4.106 Opal suggests that this principle does not offer any meaningful or useful guidance in this case. However, Opal goes on to note that the proposed Single Tandem charge would be beneficial from the perspective of the distribution of benefits principle, if Opal’s costs were lower than the Single Tandem charge. This is because Opal’s customers would benefit from the lower costs, as Opal would be able to use the difference between the Single Tandem termination charge and its cost level to help it compete at the retail level, but callers to Opal’s network would pay a charge which was the same as that levied by BT.

BT’s view

4.107 BT does not consider that this is a particularly relevant principle for consideration in this case.

⁴⁹ See Textbox 1, Section 2.

Ofcom's provisional view

4.108 Ofcom considers that Opal's argument would only hold if the termination service provided from Opal's GSX was equivalent to termination from a Single Tandem termination service on BT's network. However, as we outlined in paragraphs 4.37 to 4.41 above, we do not consider that Single Tandem call termination on BT's network is a good benchmark for the service that Opal provides from the GSX.

Practicability

Rationale:

4.109 This principle suggests that the termination rate determined should be practicable and relatively easy to implement.

Submissions by the parties

Opal's view

4.110 Opal suggests that the approach they propose is the most practical method for setting Opal's rate (as opposed to a rate based on Opal's actual costs). If the rate was equal to BT's Single Tandem rate this would be practical to determine and very simple to implement. It would also provide certainty for Ofcom, as we have studied BT's costs.

BT's view

4.111 BT did not consider this a particularly relevant principle for consideration in this case.

Ofcom's provisional view

4.112 Opal's proposal that its termination rates should be set at the BT Single Tandem termination would be simple and practical to implement. However, practicability is not unique to Opal's proposed rate – there are other charge methodologies that are also practical (e.g. a rate based on a blend of BT's local exchange and Single Tandem rates, as in the current Reciprocity Agreement). Therefore, this principle does not uniquely support Opal's proposed Single Tandem rate over alternatives.

Provisional Conclusion

4.113 Our provisional conclusion is that we do not accept the network analogy put forward by Opal as between the Single Tandem termination service on BT's network and call termination provided from Opal's GSX. We consider that the Opal NGN network is better characterised as a single layer network. As such it would not be fair and reasonable for Opal to charge rates equivalent to BT's Single Tandem termination rate for termination on its network. This is the main rationale for our provisional rejection of Opal's proposed rates in this dispute.

4.114 We also consider that the other benchmarks provided by Opal do not provide compelling support for its proposed termination charge. Kingston's Hull area network is in a unique position in the UK in relation to the termination externality, it is regulated differently from the other CPs and its rates are supported by specific evidence on its own costs. Virgin Media's rates are below the BT Single Tandem rate

and its rates are the result of the workings of the Reciprocity Agreement. Given our view on the network analogy, we do not consider that BT's rate for IP Exchange provides an appropriate benchmark.

- 4.115 Finally, our analysis of the six principles of pricing and cost recovery in relation to Opal's proposed rates provides a complementary perspective. We do not consider that the arguments put forward by Opal in respect of the six principles provide compelling support for its Opal's case.
- 4.116 In light of our proposed determination that Opal's proposed termination rate is not fair and reasonable the parties should continue to do business on the terms and conditions that have applied so far. We note that, in light of ongoing industry negotiations about future reciprocity agreements, the parties may choose to conduct further negotiations to agree an alternative method of deriving a termination rate, provided always that any such alternative rate is fair and reasonable.

Section 5

Responses to the consultation, Ofcom's conclusions, and final determination

5.1 Ofcom received responses to its consultation on the Draft Determination from:

- BT;
- Cable & Wireless (C&W);
- COLT;
- Opal; and
- One other respondent who is a CP but asked not to be named.

5.2 In this section, we summarise these comments around four themes and then set out our view on each of these themes. Our analysis includes any required clarifications and revisions of our analysis set out in Section 4. We then go on to reach a final determination to resolve this dispute, having taken into account the responses considered below.

5.3 The themes around which we have grouped the consultation responses are as follows:

- Ofcom's general approach and analysis in this dispute;
- Reciprocity;
- NGN policy development; and
- The TDM SIA.

Ofcom's general approach and analysis in this dispute

5.4 BT and Cable and Wireless were supportive of the conclusions we reached in our Draft Determination. A respondent who asked not to be named agreed "to a reasonable extent" with our reasoning.

5.5 COLT said that it was surprised that Ofcom has determined that BT is effectively connecting with Opal at the equivalent of the DLE level of the Opal network. COLT considers that Opal has argued convincingly that it operates an IP tandem layer in its network. It argues that Opal is forced to accept TDM interconnect from BT and that the necessary TDM to IP protocol converters are to all intents and purposes a tandem layer that is not reflected in the termination rates paid by BT. COLT considered that Ofcom should therefore determine that Opal can charge Single Tandem rates for terminating BT traffic in order to recover the cost of TDM to IP conversion and the extra switching in Opal's network.

- 5.6 Opal welcomed Ofcom's rejection in the Draft Determination of BT's argument that because the GSX is the point nearest to the customer where signals can be exchanged in the Opal IP network, it should be BT's DLE rate that applies.
- 5.7 On the wider approach of the Draft Determination however Opal said that it was disappointed with our draft conclusions which it believes did not represent a fair and equitable solution to the dispute. Opal considered that Ofcom has adopted an inappropriate framework for analysing whether the termination rate proposed by Opal is fair and reasonable. Opal considered that the framework adopted by Ofcom focuses almost entirely on the question set out in paragraph 4.13, namely whether call termination from Opal's GSX is equivalent to Single Tandem termination on BT's network and hence whether BT's Single Tandem charge is an appropriate reciprocal charge for Opal to make for such services.
- 5.8 Opal also noted that it had little choice in this dispute other than to set out the comparison with BT's TDM network in order to demonstrate that the proposed termination rate was fair and reasonable. Opal argued that it had to take this approach because Ofcom's previous policy statements around what constitutes fair and reasonable in this context are firmly rooted in TDM technology, which it states mean that charges should be (a) reciprocal and (b) based on BT's charges.
- 5.9 Opal maintained that it has sought to argue throughout the dispute that the closest possible reference framework for analysing an NGN would be a TDM network, but only because no other reference framework is available given that BT does not have an NGN and Ofcom has not articulated a policy for setting termination rates between TDM and NGN networks (or between NGN networks). Opal did however agree that the TDM network topology may have formed a suitable starting point for Ofcom's analysis but contends that Ofcom took the analysis too far and reached a misguided conclusion.
- 5.10 Opal argued that once Ofcom had recognised that the topologies of the Opal and BT networks are not "analogous" or "equivalent", the correct approach would have been to analyse the underlying reasons or principles for why BT is able to charge a Single Tandem termination rate and, subsequently, whether an IP network can be said to display characteristics that would equally justify the same termination rate based on those same principles.
- 5.11 Opal argued that the Single Tandem rate for termination on the BT network reflects the fact that calls are processed, managed or directed twice in the BT network in order to reach their destination and that there is normally a geographic distance between the DLE and the tandem switch which incurs additional costs (i.e. the local-to-tandem conveyance charge). Opal argued that when assessed against these principles, the Opal NGN also processes, manages and directs calls at the GSX and ASX very much like the BT DLE and tandem switches. Although there may be a shorter distance between the GSX and ASX than the BT DLE and tandem switches, Opal argues this is a logical consequence of the design of IP networks.
- 5.12 Opal also drew attention to two other differences between NGNs and TDM networks which it considers cause NGN operators to incur additional costs compared with TDM operators:
- the efficient design of an NGN means that it has much fewer points of interconnection than a TDM network. Hence an NGN operator would have to carry calls much further on its network and as a consequence incur additional

costs compared to a TDM operator who received the call much closer to the point of termination

- Opal incurs a specific and additional cost in having to convert the call traffic from TDM to IP. Opal needs to maintain the GSX in its network in order to be able to accept traffic from the BT network. This is a charge that is unique to the Opal network and does not appear in the TDM cost stack that is used to set BT's regulated rates.

Ofcom's view

- 5.13 We note that BT, C&W and a respondent who asked not to be named were supportive of our preliminary conclusions set out in the Draft Determination.
- 5.14 In response to COLT's comments about our analysis of the topology of the Opal network, we do not consider that they provide any further evidence to suggest that we should reach a different conclusion to that set out in the Draft Determination. We therefore remain of the view set out in the Draft Determination that we do not consider that Opal's network is strongly analogous with that of BT for the reasons set out in paragraphs 4.37 to 4.41 in this document.
- 5.15 We also note that COLT has incorrectly interpreted the Draft Determination as saying that BT is effectively interconnecting with Opal at the equivalent of the DLE level in the Opal network. We explicitly rejected this proposition. As discussed in more detail in paragraph 4.41 above, our provisional conclusion was that interconnection at the GSX in Opal's network is better characterised as corresponding to two interconnection services on the BT network, namely local exchange segment and Single Tandem, than to local exchange segment alone. We remain of this view.

Ofcom's views on the framework of analysis

- 5.16 We do not accept Opal's argument that our framework of analysis was flawed. Our framework for analysis was set in light of our statutory duties and Community requirements. In determining this dispute we considered Opal's reasons for its proposed rates, along with BT's arguments for rejecting such rates. In order to reach an informed decision, we have also considered further elements, including the six principles of pricing and cost recovery, information about costs (to the extent possible within our statutory timeframe), the relevant benchmarks and the stakeholders' responses to the Draft Determination.
- 5.17 As discussed in paragraph 5.2 of the Draft Determination, Ofcom restricted its analysis to the rates proposed by Opal and did not examine or propose any alternative rate; this was accepted by the parties. The termination rate proposed by Opal was based on BT's Single Tandem rate, and Opal's argument for this rate was essentially based on the (as Opal saw it) identical nature of call routing in the respective networks. We therefore considered that, given the narrow scope of the dispute, the correct approach was to consider whether or not call routing was similar on the two networks, based on Opal's argument.
- 5.18 In its response Opal said that while its NGN was not layered like a TDM network, it did "process, manage and direct the calls at both the GSX and ASX very much like what happens in the DLE and Tandem switches" in BT's network. In this respect Opal appears to be arguing that rather than simply examining whether the constituent parts of the two networks are equivalent we should consider whether, when considered as a whole, they serve the same purposes in their respective networks.

- 5.19 We consider that we have fully taken account of this issue of combined functionality of the GSX and ASX compared to a TDM network. This is part of the analysis that we have conducted and is specifically reflected in our provisional conclusion set out above at paragraph 4.41 in which we stated that GSX interconnection Opal's network is better characterised as corresponding to two interconnection services on BT's network - local exchange segment and Single Tandem – than to local exchange segment alone.
- 5.20 In its response to the Draft Determination, Opal argues that this statement, which follows the logic of previous Ofcom determinations, suggests that we have failed to analyse the Opal NGN as an IP network. We disagree. As set out above, we explicitly considered the functions of the interconnection service on Opal's NGN in our Draft Determination, and we continue to rely on this analysis in our final determination.

Ofcom's views on Opal's cost-based arguments

- 5.21 We consider that Opal's further arguments regarding the distance a call travels across the network in an NGN termination service compared to a TDM termination service and the need for an NGN to provide TDM to IP interworking introduces cost-based considerations in support of its proposed termination charges. Our understanding is that in introducing these arguments Opal is not advocating an abandonment of the principles of reciprocity to move to a termination rate based on its own actually incurred costs. Rather we understand Opal to be arguing for a modification to a termination rate set using reciprocity, to take account of unavoidable additional costs in an IP network in the current circumstances.⁵⁰
- 5.22 As regards Opal's argument that the need to carry calls further in its network will give rise to additional costs, we considered this point by reviewing the cost information which Opal has provided to us. We address TDM to IP interworking in paragraph 5.70 below.
- 5.23 In reviewing Opal's cost information, we are not suggesting that Opal's termination rate should be directly based on the cost that it actually incurs on its own network. We maintain our consistent view that the principles of reciprocity remain appropriate, as set out below. Instead our purpose is to see if there is evidence that a termination rate lower than the Single Tandem rate would deny Opal the opportunity to recover its efficiently incurred cost.
- 5.24 As noted in paragraph 4.80, Opal provided a cost model as part of its submission, but given the limited time available in the context of a dispute determination, we have not verified the costing methodology, the accuracy of the cost inputs or the model's algorithms. Paragraphs 4.80 to 4.85 above discuss our views of the data provided by Opal regarding its cost floors and cost ceilings for its termination service.
- 5.25 Following the Draft Determination, Opal provided to Ofcom further versions of the model which showed the cost of providing its termination service on a fully allocated cost (FAC) basis (i.e. the costs therefore include both the costs of resources used exclusively to terminate a voice call plus a share of the common costs of the NGN network, which can be used to provide DSL as well as voice services). This FAC data was provided on a current cost accounting (CCA) and economic depreciation basis. Diagram 2 below summarises the results for the 'TDM to LLU different node'

⁵⁰ This might be characterised as a hybrid approach, as it is neither purely reciprocal, nor purely cost-based.

service, the service whose costs Opal reported in its first submission, alongside Opal's proposed termination charges.

- 5.26 Diagram 2 shows that the CCA FAC of terminating calls via the 'TDM to LLU different node' service in the fourth quarter ("Q4") of 2009 (the first period in which the proposed charge would apply), are lower than Opal's proposed termination rate ([x]ppm compared to 0.2295ppm). Furthermore, the CCA FAC falls significantly over time. For instance, in Q4 2010 the CCA FAC in Opal's model is projected to fall to [x]ppm.

Diagram 2: Fully Allocated Costs – TDM to LLU different node service under CCA and economic depreciation [x]

- 5.27 We consider that the above figures are likely to overstate Opal's costs. As discussed in paragraph 4.84 above Opal has told us that only [x]% of Opal's termination from BT comprises the 'TDM to LLU different node' service and [x]% is via the 'TDM to LLU same node' service. Diagram 3 below summarises the results for the 'TDM to same node' service, showing that its CCA FAC are much lower than those of the other service, with CCA costs in Q2 2009 ([x]ppm) already below the proposed charge. If the costs of the two TDM to LLU services are used to provide a weighted average, the CCA FAC for Q4 2009 would be [x]ppm (compared to [x]ppm for the TDM to LLU different node) and for Q4 2010 would be [x]ppm (compared to [x]ppm for the TDM to LLU different node service).

Diagram 3: Fully Allocated Costs – TDM to LLU same node service under CCA and economic depreciation [x]

- 5.28 We also consider that the FAC figures derived using economic depreciation are likely to be a less distorted cost measure in the early years of the termination service than cost data derived using CCA (see paragraph 4.82). The results for both termination services show that economic depreciation costs are lower than the CCA costs in the early period that the services are in place and below the proposed charge for the whole time period. For instance, for the 'TDM to LLU different node service', economic depreciation FAC in Q4 2009 is [x]ppm, which is much lower than the CCA FAC and Opal's proposed charges.
- 5.29 In a later submission to Ofcom about the FAC data, Opal said that it was "confused and indeed concerned" that Ofcom was interested in this data. It noted that consideration of Opal's costs was inconsistent with Ofcom's existing policy that the termination rate should be based on BT's costs. As noted above, however, our purpose in taking account of Opal's cost evidence was not to use it as the basis to set Opal's termination rate. One of the benefits of reciprocity is that, if other operators outperform BT and can provide termination on a more efficient basis, for instance, by using technology such as NGN, then deriving charges through the use of BT's TDM based termination charges should allow them to earn a return on that greater efficiency.

- 5.30 Opal also suggested that if we were going to construct a “fair and reasonable cost model” for Opal, we would need to consider a theoretical model of the Opal network which used the same low bandwidth circuits as BT as this was “a logical consequence of using BT’s TDM costs as the base line”. This suggestion, however, is also founded on us using the cost model as the basis to set Opal’s termination rate, which is not our intent. We have explicitly not used Opal’s costs as a way to determine whether the proposed rate is fair and reasonable in line with the principle of effective competition, as set out in paragraphs 4.92 and 4.96. Instead we have considered whether it provides any evidence to suggest that a termination rate lower than the Single Tandem rate would deny Opal the opportunity to recover its efficiently incurred cost.
- 5.31 Our conclusion is that Opal’s own cost evidence does not support a view that the Single Tandem rate (or higher) is necessary to allow Opal the opportunity to recover efficiently incurred cost.

Consultation responses relating to Reciprocity and the Reciprocity Agreement

- 5.32 The following section sets out the responses we received which relate to the principle of reciprocity, consistent with the six principles of pricing and cost recovery (see paragraph 4.67 *et seq*), and the Reciprocity Agreement which expired on 30 September 2009.
- 5.33 BT supported Ofcom’s view that the principle of effective competition suggests that CPs’ “termination rates should not be based on their incurred costs, but rather on a reciprocal basis *with BT’s regulated charges*” (paragraph 4.96 above). BT believes this view is entirely consistent with previous decisions, such as the Telewest⁵¹ case, as well as Ofcom’s duties under the Communications Act to promote both effective competition and the efficient use of resources.
- 5.34 COLT argued that the principles of reciprocity were generally accepted:
- All CPs have SMP in termination of calls on their network;
 - Termination charges should not be based on actual costs, but instead the costs of the more efficient network should apply to both networks; and
 - The more efficient network should not be disadvantaged by the inefficiencies of the other network.
- 5.35 However, it said that the current methodology used in the application of this principle was neither fair nor reasonable. COLT stated that it does not support the methodology underlying the Reciprocity Agreement (the agreement up to 30 September 2009), through which BT pays a termination charge based on the DLE/Tandem split of the CP’s traffic to BT, irrespective of whether BT interconnects at the CP’s DLE or Tandem layer. COLT argued that Ofcom was wrong to continue to support this methodology.

⁵¹ Determination to resolve a dispute between BT and Telewest about geographic call termination reciprocity agreement, Ofcom, June 2006.

- 5.36 COLT also noted that the recent NCC statement⁵² increases the termination charges that BT can levy. COLT stated that Ofcom's justification for these increased termination charges is that BT is carrying fewer voice minutes over its TDM network and therefore each minute carries a higher proportion of BT's fixed costs. COLT argued that it is no longer clear that BT runs the most efficient network and Ofcom should reconsider the assumption that BT is the most efficient operator. Instead, COLT argued, reciprocal termination rates between networks should be based on the costs of the more efficient of the two networks. It also argued that the most recent Reciprocity Agreement creates disincentives for further investment in network rollout.
- 5.37 COLT considered that Ofcom should now concede that the present methodology for reciprocity, now 12 years old, is not necessarily the best way to determine fair and reasonable CP termination rates. COLT would like to see Ofcom consult on a new methodology which reflects the actual methods of traffic delivery by BT.
- 5.38 One other respondent who asked not to be named also raised issues relating to industry negotiations on the new Reciprocity Agreement. They considered that the Draft Determination would not help with the industry negotiations and that Ofcom would need to address the issue of all geographic termination rates for all operators at some point in the coming months.
- 5.39 Opal did not add to its comments on reciprocity made in earlier submissions but argued that if this Determination follows the view of the Draft Determination then "it is of utmost importance that Ofcom gives as much detailed guidance as possible to the parties to enable the efficient and orderly conduct of future negotiations".

Ofcom view on the principle of reciprocity

- 5.40 We have noted the requests for both general guidance as to how reciprocal rates can be set and specific guidance as to how Opal and BT should proceed in this case.
- 5.41 We agree with COLT that there is a clear distinction between the principle of reciprocity and the specific industry Reciprocity Agreement which represents one particular implementation of this principle in practice. We have used this opportunity to set out our high-level views on the essential characteristics of a reciprocal termination charges regime.
- 5.42 However we do not consider it appropriate in the context of this dispute to provide more specific guidance as to alternative methods of arriving at a fair and reasonable termination rate for TDM to IP termination (i.e. alternative implementations of the principle of reciprocity). We consider that providing such specific guidance is outside the scope of this dispute and would potentially pre-judge matters of NGN policy which have recently been the subject of consultation.

Principle of reciprocity

- 5.43 As noted in paragraphs 4.12 to 4.15, in 1997 Oftel expressed support for the principle of reciprocity. The aim of reciprocity was to ensure competitive neutrality between BT and other CPs and to remove the distortive effects of the call termination

⁵² Review of BT's Network Charge Controls, Explanatory Statement and Notification of decisions on charge controls in wholesale narrowband markets, 15 September 2009, http://www.ofcom.org.uk/consult/condocs/review_bt_ncc/statement/

externality.⁵³ Oftel identified the following key objectives (which reflect the six principles of pricing and cost recovery⁵⁴):

- promoting effective competition by ensuring competitive neutrality;
- providing operators with sound make-or-buy investment signals;
- giving strong incentives for operators to minimise costs; and
- choosing an approach that is practical to implement.

5.44 In the recent consultation on fixed narrowband services⁵⁵ Ofcom noted that:

“Ofcom continues to be of the view that “fair and reasonable” should include the principle of reciprocity, taking into account differences in networks, and that BT’s costs are likely to be close to those of an efficient network. As BT and other terminating CPs progress in their migration from legacy networks to NGNs, the question of what constitutes an efficient cost base and how differences in networks should be taken into account under various migration scenarios will need to be addressed.”

5.45 Our current view is that the essential characteristics of a reciprocal termination charges regime are that:

- the termination charges levied by at least one network are based on an assessment of its efficiently-incurred costs;
- these charges are used as the reference point for the termination charges which can be levied by competitor networks; and
- the actual termination charges levied by competitor networks are derived from this reference point in a manner which is consistent with the six principles of pricing and cost recovery.

5.46 BT’s termination charges have been set through the Network Charge Control process, which sets BT’s charges based on an analysis of efficient costs so as to encourage efficiency on the part of BT in the delivery of its TDM network services. Oftel and Ofcom have taken the view that BT’s termination charges are therefore the appropriate reference point for other fixed network operators; we remain of this view.

Methodology

5.47 Oftel’s 1997 Statement noted that it was for BT and industry to agree the methodology for applying the principle of reciprocity.

5.48 The approach underlying the Reciprocity Agreement which expired on 30 September was to calculate a single charge for other CP’s call termination as a weighted average of BT’s local exchange segment and Single Tandem segment charges,

⁵³ Oftel: Network Charges from 1997, July 1997. See also: Review of the fixed narrowband services wholesale markets: Consultation on the proposed markets, market power determinations and remedies, March 2009, paragraph 2.82

⁵⁴ Sound make-or-buy investment signals is one aspect of the principle of cost causation. The remaining principles not included in the list are the ‘distribution of benefits’ and ‘reciprocity’ itself.

⁵⁵ Review of the fixed narrowband services wholesale markets: Consultation on the proposed markets, market power determinations and remedies, March 2009, paragraphs 2.84 – 2.85

using actual volumes of the CP to BT *traffic* to compute the weights. Oftel identified this as one of its preferred approaches in the 1997 statement.

- 5.49 We remain of the view that the methodology for calculating competitors' termination charges from those of BT should be agreed by industry, subject to the resulting charges meeting the objectives described above, and recognising that a degree of trade-off may be needed. We understand that Opal has recently (since responding to the Draft Determination) proposed a new termination rate to BT.
- 5.50 We recognise that, in devising an approach, there may be a degree of trade-off between the objectives outlined in paragraph 5.44. The extent to which a proposed charge meets the objectives will be a matter of judgement for the industry, and, in case of dispute, for Ofcom. As such there may be a variety of methodologies which could be developed to provide reciprocity using BT's charges, and more than one of them could be fair and reasonable.
- 5.51 For example, in the 1997 Statement⁵⁶, the Director General noted that the preferred approach described above had a distortive effect on make or buy decisions. However, the Director General considered that they were more than offset by other advantages such as competitive neutrality.
- 5.52 In resolving the BT / Telewest dispute (regarding termination rates on Telewest's TDM networks)⁵⁷, we noted that:

“Ofcom considers that the concept of fair and reasonable pricing is that which strikes a good balance in meeting the [six principles of pricing and cost recovery], whilst recognising that there may be a conflict between some of these objectives.”

- 5.53 We are currently considering responses to our consultation on Next Generation Networks policy⁵⁸, which invited views on the application of reciprocity to IP networks (see paragraphs 5.59 to 5.72). We acknowledge the importance of this set of issues and we are now considering how to take these questions forward following the responses we have received both to the NGN consultation and to the consultation on the draft determination. We aim to set out our initial conclusions in the forthcoming NGN statement, and these may lead us to undertake further work. In the meantime, we remain of the view that the industry is best placed to take the issues forward by negotiation.

Ofcom's view on the Reciprocity Agreement

- 5.54 COLT raised a range of concerns about the industry Reciprocity Agreement which has been used as a mechanism for setting termination charges. Most of these concerns were not specific to NGNs and, in our view, fall outside the scope of this dispute, which necessarily focuses more narrowly on the dispute between Opal and BT about the termination rate for the Opal NGN.

⁵⁶ Oftel: Network Charges from 1997, July 1997, Annex C, paragraph C.22. Also cited in Ofcom: Determination to resolve a dispute between BT and Telewest about geographic call termination reciprocity agreement, June 2006.

⁵⁷ Determination to resolve a dispute between BT and Telewest about geographic call termination reciprocity agreement, Ofcom, June 2006.

⁵⁸ Next Generation Networks: Responding to recent developments to protect consumers, promote effective competition and secure efficient investment; July 2009.
<http://www.ofcom.org.uk/consult/condocs/ngndevelopments/>

- 5.55 We have noted in this Determination that the Reciprocity Agreement that expired on 30 September 2009 has previously been found by Ofcom to be fair and reasonable (while also noting that other ways of arriving at termination rates might additionally or alternatively be fair and reasonable). However, we would expect that the current negotiations within the industry will address the issues of termination rates for CPs migrating from legacy networks to NGNs.
- 5.56 We have also recently considered stakeholders' views about the reciprocity arrangements in the Wholesale Narrowband Market Review⁵⁹. We took the view that it would be appropriate for industry to establish a new reciprocity agreement rather than for Ofcom to impose it as a regulatory requirement.
- 5.57 The question of whether BT should continue to be regarded as the most efficient network for the purposes of termination charging was also considered in some detail in the Wholesale Narrowband Market Review. We reconfirmed our view that 'fair and reasonable' in relation to termination charges should include the principle of reciprocity taking into account the differences between networks. We also concluded that BT costs were likely to be close to those of an efficient operator.
- 5.58 As discussed at paragraph 5.44, in relation to the manner in which competitor networks' termination charges are derived from BT's charges, we remain of the view that this should be agreed by industry. In our view, it would be premature at this stage for Ofcom to take action regarding the form of a new Reciprocity Agreement whilst the industry negotiations are ongoing. However, in the context of the NGN consultation, we will set out our initial conclusions in the forthcoming NGN statement and this may lead us to do further work in this area.

Consultation responses regarding NGN policy development

- 5.59 Opal stated that if Ofcom decided to confirm its initial conclusions it would be of paramount importance that Ofcom sets out as clearly as possible the principles which should be used to determine a fair and reasonable termination rate for the Opal NGN and other NGNs. Opal said that otherwise BT would reject any further termination rate proposal by Opal, leading to a further dispute which Ofcom may have to resolve.
- 5.60 In particular, Opal urged Ofcom to explain the extent to which an NGN operator could include in its termination rate a mark-up to cover the cost of TDM to IP conversion over and above the termination rate set by the formula in the Reciprocity Agreement that expired on 30 September 2009.
- 5.61 Further Opal stated that it does not accept that the UK telecoms industry is in a transitional phase between TDM and IP. Whilst BT has failed to roll-out NGN according to its initial timetable and has recently decided to slow down rollout significantly, Opal considers that at this stage it is reasonable to expect any operator who has failed to convert to IP to bear the TDM to IP conversion costs of operators who have made the transition in accordance with the previously agreed industry timetable. Opal also notes that NGN operators have to bear the costs of converting IP to TDM on traffic originating on their networks that is bound for TDM networks. Given this, Opal argues that it would be entirely reasonable to effectively split the combined cost of TDM-IP-TDM conversion on a 50/50 basis between the NGN operator and the TDM operator.

⁵⁹ Review of the fixed narrowband services wholesale markets, Consultation on the proposed markets, market power, determinations and remedies, 19 March 2009.
http://www.ofcom.org.uk/consult/condocs/review_wholesale/

- 5.62 Opal pointed out that in the NGN consultation, Ofcom has accepted that NGN operators incur additional interworking costs relative to the situation when both operators use IP interconnection and that NGN operators have to invest in interworking equipment that will eventually become redundant or less productive as TDM traffic declines.
- 5.63 Opal also noted that in the NGN consultation Ofcom said that BT's IP Exchange product uses *"regulated TDM components as inputs, and then adds interworking functions and a commercial wrap. For this reason, the prices for termination and transit can be higher than the equivalent regulated rates for TDM interconnection."*⁶⁰ Opal argues that this statement suggests that Ofcom accepts that BT is able to charge a mark-up for TDM to IP interworking functionality.
- 5.64 C&W was concerned about the wider policy implications which may be drawn from some of the reasoning set out in the Draft Determination. C&W also suggested that the arguments used to determine the dispute do not draw upon the draft policy conclusions in Ofcom's recent NGN consultation. In the absence of clarification, it considered that stakeholders may draw inappropriate conclusions in respect of future regulatory policy and decision making in NGN interconnection.
- 5.65 C&W said that it was important to highlight that any reasoning in the Draft Determination is limited to TDM to IP interconnect arrangements and should not fetter Ofcom or industry consideration of future NGN to NGN (SIP-I) interconnection. C&W states that in its response to the NGN consultation it argued that NGNs fundamentally separate media conveyance from call control, and therefore believes that this should be reflected in any future charging regime.
- 5.66 C&W also notes that in the NGN consultation Ofcom has stated that first movers to NGN technology would take account of interworking costs when determining a business case for deployment⁶¹. It also states that Ofcom concludes that IP technology cannot yet be considered a "proven" technology, nor will it likely be so within the next NCC period⁶². In the absence of the technology being proven, C&W argues that it cannot be right that CPs be expected to interconnect using IP technology in order to secure the lowest termination rates. C&W therefore argues that, regardless of subsequent arguments in the Draft Determination as to whether a call server is analogous to a switch, the nearest proven handover point to the customer line in Opal's network is the GSX, and CPs should not be penalised for failing to utilise IP interconnection to the ASX/NBS.
- 5.67 C&W expressed concern that our characterisation of Opal's IP core as being analogous to a single switching layer fails to make clear that this is only the case where handover is at the entry point to the IP core nearest to the network termination point; for TDM interconnect this is the nearest GSX, for future NGN interconnect it would be the nearest NBS. Furthermore, due to considerations of call control effort in an NGN interconnect context, C&W considered that the number of call servers (ASX) involved in terminating a call will become material. C&W has asked that Ofcom clarifies in the final determination that the considerations around whether call server stages are material is limited to the narrow scope of the dispute and should not constrain future thinking on NGN to NGN interconnection arrangements.

⁶⁰ Paragraph 3.134, Next Generation Networks, responding to recent developments to protect consumers, promote effective competition and secure efficient investment, 31 July 2009.

⁶¹ Paragraph 3.109

⁶² Paragraph 3.125

Ofcom's views

- 5.68 Ofcom has recently consulted stakeholders on a range of issues arising from the deployment of NGNs. The consultation which closed on 24 September 2009 considered the interconnection charging arrangements for NGNs in some detail and also discussed when IP interconnection should be introduced and who should be responsible for interworking costs during the transition from TDM networks to NGNs.
- 5.69 We acknowledge Opal's request for further guidance about the principles that should be used to determine a termination rate for Opal's NGN and NGNs more generally. However, having recently asked for stakeholders' views on NGN interconnection, we consider that any such guidance is best provided in the context of the forthcoming policy statement once we have evaluated stakeholders' comments. In our view it would not be appropriate to set out a definitive Ofcom view in advance of those considerations or in the context of this dispute given its limited scope.
- 5.70 Regarding Opal's request for Ofcom to clarify whether NGN operators should be allowed to include a mark-up in their termination charges for TDM to IP conversion and C&W's comments about interworking costs, we note that interworking costs were discussed in the recent NGN consultation. In paragraph 3.126 of the NGN consultation we suggest that we may currently be at an early stage of the transition from TDM networks to NGNs and given this it may be reasonable to assume that the efficiency savings of NGNs for first movers such as Opal would be sufficient to offset the costs of interworking. [36]. Beyond this observation, we believe that this issue is best considered by Ofcom following a full consideration of stakeholder responses to the NGN consultation.
- 5.71 Citing our description of the BT IP Exchange service in the NGN consultation, Opal suggested that Ofcom accepts that BT is allowed to charge a higher termination rate to cover the provision of TDM to IP interworking. The IP Exchange service is an unregulated commercial offering by BT and therefore Ofcom has not taken a formal view about additional charges for interworking in the context of this service.
- 5.72 Further, as an early adopter of an NGN, Opal has self-provided IP to TDM interworking in order to interconnect with BT's TDM network using standard TDM interconnection links. The evidence suggests that Opal will have achieved cost savings with its NGN against which interworking costs can be offset. However, this is not the case with IP Exchange where BT provides IP to TDM interworking for its existing TDM network as a commercial extra for other early adopters of NGNs so that they can avoid having to self-provide IP to TDM interworking.
- 5.73 We also note that in any event, as discussed in paragraphs 4.64 and 4.65, Ofcom does not accept that BT's IP Exchange service is a relevant benchmark for Opal's NGN termination service.
- 5.74 We also considered the issue of investment incentives in our Draft Determination and we remain of the view that this Determination will not deter investment in NGNs (for the reasons set out at paragraphs 4.80 to 4.85).
- 5.75 In our view, our conclusions in this dispute are consistent with the discussion about NGN interconnection in the NGN consultation in so far as they are relevant. Regarding C&W's comments about Ofcom's conclusion that the IP core of Opal's network is best characterised as having a single switching layer, we note that this conclusion was drawn in the context of our consideration of the network analogy proposed by Opal. We understand C&W's concerns about the entry point to the IP

core and the number of call servers, and we confirm that our analysis in this Determination is restricted to the specific circumstances applicable to this dispute.⁶³ We do not consider that our views in relation to this dispute would fetter our discretion in relation to our consideration of IP to IP (SIP) interconnection arrangements. Nor should our conclusions be interpreted as pre-judging industry discussions about future NGN interconnection arrangements.

The TDM Standard Interconnect Agreement (SIA)

5.76 C&W noted that it agrees with our analysis that *for the purposes of the [TDM] SIA* the ASX does not meet the definition of a switch, and the elements of Opal's IP core should be considered as a holistic unit.

Ofcom's response on the TDM SIA

5.77 To clarify, Section 4, paragraph 4.39, states that:

“In our view, the ASX is a call control function that resides at the IP Core Network and is not a switching function that resides at a lower layer of the network than the GSX as argued by Opal. It is not possible for other Communications Providers to connect directly to the ASX as suggested by Opal in its first submission.”

5.78 Whilst we maintain this view, we did not conclude, as suggested by C&W, that the ASX does not meet the definition of “switch” for the purposes of the SIA.

Conclusion

5.79 We have considered carefully all of the responses we received to the Draft Determination, and have set out above our views on those responses. For the reasons set out above, we do not consider that the issues raised in response to our Draft Determination are such that our analysis and conclusions as set out in the Draft Determination should change. Therefore, for the reasons set out in Sections 4 and 5 above, our final conclusions remain as set out in the Draft Determination.

5.80 We have therefore determined that, should Opal provide fixed geographic termination rate to BT on the terms set out in OCCN 654, such provision would not be regarded as being on fair and reasonable terms, conditions and charges under SMP Condition BC1. Our formal determination to this effect is set out at Annex 1.

5.81 In response to various responses to the Draft Determination, we have in addition sought to re-iterate the principles which support reciprocity and, where appropriate, provided clarity where there was a possibility of stakeholders misunderstanding our conclusions.

5.82 In light of this Determination, the parties should continue to do business on the terms and conditions that have applied so far. We note that, in light of ongoing industry negotiations about future reciprocity agreements, the parties may choose to conduct further negotiations to agree an alternative method of deriving a termination rate, provided always that any such alternative rate is fair and reasonable. We also note in this regard that Opal issued a new OCCN to BT on 30 September 2009, to take effect from 1 October 2009. We assume that this new OCCN is intended to

⁶³ Except where we explicitly comment on wider issues, such as our high-level views on the essential characteristics of a reciprocal termination charges regime in paragraphs 5.43 to 5.46.

supersede OCCN 654 which prompted Opal to bring this dispute to Ofcom in the first place. This new OCCN has proposed a rate which [~~is~~] proposed by Opal in OCCN 654 and the termination rate in place until 30 September 2009. Opal has told us that it is still negotiating on this matter with BT.

Assessment of our determination against Ofcom's statutory duties and Community requirements

5.83 We have carefully considered our powers, obligations and duties in deciding on the appropriate means of resolving this dispute. For the reasons set out below, we consider that our determination to resolve this dispute is consistent with both Ofcom's general duties in section 3 of the Act, and (pursuant to section 4(1)(c) of the Act) the six Community requirements set out in section 4 of the Act, which give effect, amongst other things, to the requirements of Article 8 of the Framework Directive.

5.84 We consider that the following duties have particular relevance to this dispute:

- (i) the duty to further the interests of citizens (i.e., all members of the public in the United Kingdom) in relation to communication matters (section 3(1)(a));
- (ii) the duty to further the interests of consumers in the relevant markets, where appropriate by promoting competition (section 3(1)(b));
- (iii) the duty to secure the availability throughout the United Kingdom of a wide range of electronic communications services (section 3(2)(b));
- (iv) the duty to have regard to the principles under which regulatory activities should be transparent, accountable, proportionate, consistent and targeted only at cases in which action is needed; as well as any other principles appearing to Ofcom to represent the best regulatory practice (section 3(3));
- (v) the duty to have regard to the desirability of promoting competition in relevant markets (section 3(4)(b));
- (vi) the duty to have regard to the desirability of encouraging investment and innovation in relevant markets (section 3(4)(d));
- (vii) the duty to have regard to the different interests of persons in the different parts of the United Kingdom, of the different ethnic communities within the United Kingdom and of persons living in rural and in urban areas (section 3(4)(l));
- (viii) The duty to have regard to the extent which, in the circumstances of the case, the furthering or securing of the matters mentioned in section 3(1) and 3(2) is reasonably practicable.
- (ix) the duty to have regard, in particular, to the interests of consumers in respect of choice, price, quality of service and value for money (section 3(5));
- (x) the duty to promote competition (section 4(3));
- (xi) the duty to secure that Ofcom's activities contribute to the development of the European internal market (section 4(4));
- (xii) the duty to promote the interests of all persons who are citizens of the European Union (section 4(5));

- (xiii) the duty to ensure technology neutrality (section 4(6));
 - (xiv) the duty to encourage, to the extent Ofcom considers it appropriate, the provision of network access and service interoperability for the purposes of securing efficiency and sustainable competition in communications markets and the maximum benefit for the customers of communications network and services providers (sections 4(7) and 4(8)).
- 5.85 We consider that the duties set out at (ii), (iii), (v), (vi), (viii), (ix), (x), (xii), (xiii) and (xiv) are of particular relevance for resolving this dispute since Opal and BT consider that the resolution of this dispute could have an impact on competition and, therefore, on the offer of electronic communications services to consumers in terms of choice, price, quality of service and value for money.
- 5.86 The principle of effective competition requires that charges imposed should not undermine the pressure for effective competition (whether competition between those already in the market place or competition via entry by efficient operators). We do not consider that Opal has demonstrated that its proposal is supported by the principle of effective competition, because its proposed charges would not be appropriately reciprocal, as BT's network is not a good analogy for termination at the GSX on Opal's network. Further, that we do not consider that the Single Tandem termination rate would provide for competitive neutrality in the market place. These issues are discussed further in paragraphs 4.91 to 4.99 above.
- 5.87 In our analysis we have sought to adopt a technology neutral approach which does not favour the use of any particular technology (as set out at (xiii)), whether that used by Opal's network or BT's network. In doing so we also sought to ensure the development of new and innovative services (as set out at (vi)). We have an interest in ensuring that the development of Next Generation Networks is not hampered as a result of this determination.
- 5.88 We also consider that the duties set out at (i), (vii) and (xii) are relevant to this dispute as there is a potential for rural areas to be disadvantaged if investment in NGN technology favours high population density urban areas. We have not identified reasons why, as a result of our proposed determination, investment in rural areas would be unduly deterred.
- 5.89 In addition we consider that the duty set out in sections 4(7) and (8) of the Act is also relevant, namely the duty to encourage the provision of network access and service interoperability for the purposes of securing efficiency and sustainable competition in communications markets and the maximum benefit for the customers of communications network and services providers. We consider this duty to be of relevance for resolving this dispute since this dispute concerns the service of call termination, which is essential for encouraging interoperability between different networks, so that customers of one network can call, and receive calls from, the customers of other networks. Further, given that the service of call termination facilitates the development of communications between customers of different networks, we consider it relevant also for the purpose of development of the European internal market. As set out in paragraphs 4.96 to 4.99 we consider that our proposed outcome promotes effective competition. Furthermore, by ensuring that the termination rate payable by BT is not excessive, we have helped to ensure that customers of BT and other networks are able to call Opal's customers.
- 5.90 We consider that our duty set out in section 3(4)(d) of the Act is relevant to the resolution of this dispute, namely to have regard to the desirability of encouraging

investment and innovation in relevant markets. Our review of Opal's cost model is relevant to the issue of network investment. We have compared the evidence in Opal's cost model with the proposed termination rate (Section 4 paragraphs 4.80 to 4.85). We do not consider that our proposed determination will deter investment in the relevant market because under SMP Condition BC1 Opal is entitled to receive a fair and reasonable termination rate from BT.

5.91 We consider our duty set out in section 3(4)(m) of the Act is relevant to the resolution of this dispute. As the outcome of this dispute is that existing arrangements will continue until the parties agree otherwise, we consider that our proposed outcome is reasonably practicable.

5.92 Finally, we consider our duties set out in Section 3(3) of the Act to be relevant, namely to have regard to the principles under which regulatory activities should be transparent, accountable, proportionate, consistent and targeted only at cases in which action is needed, as well as any other principles appearing to us to represent the best regulatory practice. In particular:

- **Transparency and Accountability:** we consider that this document clearly sets out the parties' arguments and our reasoning that underpins our conclusion, and we note that the parties have had an opportunity to comment on our proposed conclusions in advance of our final determination.
- **Proportionate:** We consider that our proposal is proportionate because its effect is for the current arrangements between the parties to remain until otherwise agreed between them.
- **Consistency:** in developing our approach, we consider that our proposed decision is consistent with previous decisions⁶⁴ and, in particular, with the approach to reciprocity outlined in the Telewest dispute in 2006.
- **Targeted:** Our resolution is targeted in that it resolves the dispute as between the parties to the dispute.

⁶⁴ See footnote 35.

Annex 1

The Determination

Dispute between Opal and BT

Determination under sections 188 and 190 of the Communications Act 2003 (“2003 Act”) for resolving a dispute between Opal Telecom Limited “Opal” and British Telecommunications plc “BT” concerning the termination rate payable by BT for calls originating on or transiting across BT’s fixed network for termination on Opal’s fixed network.

WHEREAS—

(A) section 188(2) of the 2003 Act provides that, where Ofcom has decided pursuant to section 186(2) of the 2003 Act that it is appropriate for it to handle the dispute, Ofcom must consider the dispute and make a determination for resolving it. The determination that Ofcom makes for resolving the dispute must be notified to the parties in accordance with section 188(7) of the 2003 Act, together with a full statement of the reasons on which the determination is based, and publish so much of its determination as (having regard, in particular, to the need to preserve commercial confidentiality) they consider appropriate to publish for bringing it to the attention of the members of the public, including to the extent that Ofcom considers pursuant to section 393(2)(a) of the 2003 Act that any such disclosure is made for the purpose of facilitating the carrying out by Ofcom of any of its functions;

(B) section 190 of the 2003 Act sets out the scope of Ofcom’s powers in resolving a dispute which may, in accordance with section 190(2) of the 2003 Act, include—

- making a declaration setting out the rights and obligations of the parties to the dispute;
- giving a direction fixing the terms or conditions of transactions between the parties to the dispute;
- giving a direction imposing an obligation, enforceable by the parties to the dispute, to enter into a transaction between themselves on the terms and conditions fixed by Ofcom; and
- for the purpose of giving effect to a determination by Ofcom of the proper amount of a charge in respect of which amounts have been paid by one of the parties to the dispute to the other, giving a direction, enforceable by the party to whom sums are to be paid, requiring the payment of sums by way of adjustment of an underpayment or overpayment;

(C) on 19 March 2009, Opal issued Operator Charge Control Notice (“OCCN”) 654 to BT, whereby Opal proposed a rate equivalent to the BT Single Tandem termination rate, as published in BT’s current Carrier Price List, for terminating on Opals network calls originating on, or transiting across, BTs fixed network, with effect from 1 October 2009;

(D) on 9 April 2009, BT rejected OCCN 654;

(E) on 3 June 2009, Opal submitted a dispute with BT to Ofcom for resolution;

(F) on 26 June 2009, Ofcom decided that it was appropriate for it to handle the dispute, and informed the parties of this decision;

(G) on 26 June 2009, Ofcom published details of the dispute on its website and invited comments from stakeholders on the scope of the dispute;

(H) on 26 June 2009, Ofcom set the scope of the dispute to be resolved as to determine whether the fixed geographic termination rate proposed by Opal to BT in its OCCN 654 with effect from 1 October 2009 for terminating on Opals network calls originating on, or transiting across, BTs fixed network, is fair and reasonable in accordance with SMP Condition BC1; this rate being equivalent to the BT Single Tandem termination rate as published in their current Carrier Price List;

(I) a non-confidential Draft Determination was sent to the parties on 11 September 2009 and published on Ofcom's website on 14 September 2009;

(J) in order to resolve this dispute, Ofcom has considered (among other things) the information provided by the parties and Ofcom has further acted in accordance with its general duties set out in section 3 of, and the six Community requirements set out in section 4 of the 2003 Act;

(K) a fuller explanation of the background to the dispute and Ofcom's reasons for making this Determination is set out in the explanatory statement accompanying this Determination; and

NOW, therefore, Ofcom makes, for the reasons set out in the accompanying explanatory statement, this Determination for resolving this dispute—

I Declaration of rights and obligations, etc.

- 1 It is hereby declared that, should Opal provide fixed geographic termination rate to BT on the terms set out in OCCN 654, such provision would not be regarded as being fair and reasonable terms, conditions and charges under SMP Condition BC1;
- 2 Opal and BT should continue do business on the terms and conditions that have applied so far until they agree otherwise.

II Binding nature and effective date

- 3 This determination is binding on Opal and BT in accordance with section 190(8) of the 2003 Act;
- 4 This Determination shall take effect on the day it is published.

III Interpretation

- 5 For the purpose of interpreting this Determination—
 - a) headings and titles shall be disregarded; and
 - b) the Interpretation Act 1978 shall apply as if this Determination were an Act of Parliament.
- 6 In this Determination—
 - a) **“2003 Act”** means the Communications Act 2003 (c.21);

- b) **“BT”** means British Telecommunications plc (BT) is a wholly whose registered company number is whose registered company number is 1800000, and any of its subsidiaries or holding companies, or any subsidiary of such holding companies, all as defined by section 736 of the Companies Act 1985, as amended by the Companies Act 1989;
- c) **OCCN 654** means Operator Charge Change Notice 654 issued on 19 March 2009;
- d) **“Ofcom”** means the Office of Communications;
- e) **“Opal”** means Opal Telecom Limited whose registered company number is 3849133, and any of its subsidiaries or holding companies, or any subsidiary of such holding companies, all as defined by section 736 of the Companies Act 1985, as amended by the Companies Act 1989;
- f) **“SMP Condition BC1”** means:
 - (i) Significant Market Power Condition BC1 as contained in the Review of fixed geographic call termination markets identification and analysis of markets, determination of market power and setting of SMP conditions: Final Explanatory Statement and Notification, 28 November 2003 [http://www.ofcom.org.uk/static/archive/oftel/publications/eu_directives/2003/eu_geo_term/fix_geo3.htm] and as set out at part 2 of Schedule 3 of the Notification to the Market Review for the period 28 November 2003 to 14 September 2009; and
 - (ii) Significant Market Power Condition BC1 as contained in the Review of the wholesale fixed narrowband markets: Statement on the markets, market determinations and remedies including further consultation, 15 September 2009 [http://www.ofcom.org.uk/consult/condocs/wnmr_statement_consultation/main.pdf] and as set out at part 2 of Schedule 3 of the Notification at Annex 7 to the Market Review for the period from 15 September 2009.

Neil Buckley

Director of Investigations

A person duly authorised in accordance with paragraph 18 of the Schedule to the Office of Communications Act 2003

23rd October 2009