



## BT's response to Ofcom's consultation Document

### *“Narrowband Market Review*

*Further Consultation Proposals on price notification remedies in the WCT markets  
and regulation of BT's interconnect circuits.”*

**NON CONFIDENTIAL VERSION**

**7 August 2017**

## **Contents**

Executive Summary

Section 1: Price notification remedies in the WCT markets

Section 2: Remedies on BT: delivery of traffic to BT's terminating and originating switches using IP interconnection

## Executive Summary

1. TDM and IP networks have co-existed for over ten years now and Ofcom concludes correctly that the current interconnect arrangements are working well.
2. CPs are currently well served by commercial offerings for both transit and IP based interconnection services. There are a wide range of options available to CPs to connect both TDM and IP networks to access the regulated TDM WCO and WCT services, both directly with BT or via third party operators. There are high volumes of TDM interconnect circuits linking CP networks to BT's DLEs. A number of CPs successfully operate IP networks whilst being able to deliver traffic to BT's TDM for termination.
3. IP networks can use TDM interconnect circuits to connect to TDM networks. There is therefore no obsolescence in the interconnect link, even if a CP's TDM network is migrated to IP. The availability of media gateways with STM-1 or STM-4 interfaces mean that equipment is available to CPs to interconnect with BT's TDM network.
4. BT's view is that the effective operation of the market makes Ofcom's proposed remedies disproportionate. CPs can and do use a broad range of alternatives to BT's TDM interconnect circuits for accessing WCO and WCT services. These additional choices have evolved through the competition in the conveyance and transit markets whilst allowing IP interconnection services to develop without the interference of regulatory remedies. This approach has been supported by Ofcom's own investigations in previous market reviews which have shown that conveyance and transit services are competitive. As a consequence, they are now unregulated.
5. BT is concerned that a "Fair and Reasonable" remedy on BT's commercially supplied IP exchange services if CPs choose to close their TDM networks is unnecessary and disproportionate. BT has been interconnecting at IP for approximately 10 years on a commercial basis and without the need for any ex-ante regulation. Ofcom is proposing to extend regulation to a potential future scenario without considering how this will impact on the reciprocal nature of these interconnect relationships or whether it should also apply to other CPs.
6. By proposing now a "Fair and Reasonable" obligation for the delivery of traffic to BT's DLEs via IP interconnection, including transit and conveyance, Ofcom is extending the scope of regulation without any evidence that it is required to make its WCT and WCO remedies effective. Indeed, the evidence suggests that it is not required. Ofcom has consistently found that conveyance and transit are competitive including in its December 2016 Consultation. Moreover, before imposing "Fair and Reasonable" requirements, Ofcom should consider, amongst other things, the availability of alternatives to IP interconnection from BT as well the feasibility of reverting back to TDM interconnection. Unnecessary regulation often produces unintended and adverse consequences such as the distortion of investment decisions and the disruption to existing commercial arrangements. In this way, Ofcom's proposals risk damaging a competitive market that currently operates effectively.

## Section 1: Price notification remedies in the WCT markets

*Question 2.1: Do you agree with our proposed obligation on all telecoms providers with SMP in the WCT markets to notify Ofcom annually of the FTRs they have charged? Please provide reasons and evidence in support of your views.*

7. Under the Standard Interconnect Agreement (SIA) BT must give 56 days' notice of price changes.
8. Within the Narrowband Market Review Consultation<sup>1</sup>, Ofcom proposes to reduce BT's notice period to publication on or before the day the charges take effect. Although this reduction is welcome, BT continues to be governed by the SIA.
9. BT is concerned that Ofcom's proposal to publish the maximum permitted WCT charges two months in advance of the change in the FTR cap provides BT with insufficient notice to update all its prices within the agreed SIA notice period of 56 days.
10. BT supports the proposal that BT should no longer be obliged to publish a network tariff gradient.
11. BT proposes that Ofcom provides an additional 2 weeks' notice of the FTR cap and notifies the maximum permitted FTR charge 75 days in advance of the changes taking effect. This will allow BT to meet its price notification obligations under the SIA and to seek corresponding appropriate changes to WCT charges it pays to other operators.
12. BT has no objection to providing Ofcom with the FTRs charged in the previous charge control year, within one month of the end of the control period. Indeed, BT routinely includes Ofcom in the circulation of Access and Network Charge Change Notices (published under the terms of the SIA) whenever we change the prices for BT services.

---

<sup>1</sup> <https://www.ofcom.org.uk/consultations-and-statements/category-1/narrowband-market-review>

## Section 2: Remedies on BT: delivery of traffic to BT's terminating and originating switches using IP interconnection

*Question 3.1: Do you agree with the remedy we propose in relation to interconnection, so far as they may relate to IP interconnection? Please provide reasons and evidence in support of your views.*

### *Summary*

13. BT does not agree with the proposed remedy. BT considers the potential extension of the scope of regulation from TDM interconnection to IP interconnection to be unwarranted and unjustified. BT is concerned that Ofcom is extending existing regulation in anticipation of a particular market scenario which is unlikely to materialise. Ofcom must establish that the extension in scope is necessary, objective, proportionate and non-discriminatory before it is introduced.
14. BT agrees with Ofcom that the current obligations to provide TDM interconnect circuits to telecoms providers are sufficient to ensure that the WCO and WCT remedies are effective. On the other hand, BT disagrees with Ofcom over the need to regulate a currently unregulated and competitive service (IP Exchange) by making it subject to a "fair and reasonable" pricing obligation.
15. The "IP Interconnection service", as envisaged by Ofcom, includes not only the interconnect link connecting the telecoms provider's network to BT but also the transit and conveyance services linking BT's IP Exchange through to the DLE exchanges. The proposal for "fair and reasonable pricing" would therefore unfairly extend regulation into the competitive local-tandem and inter-tandem elements of the core market.
16. CPs are currently well served by commercial offerings for both transit and IP based interconnection services. There are a wide range of options available to CPs to connect both TDM and IP networks to access the regulated TDM WCO and WCT services, both directly with BT or via third party operators. There are high volumes of TDM interconnect circuits linking CP networks to BT's DLEs. A number of CPs successfully operate IP networks whilst being able to deliver traffic to BT's TDM for termination.
17. IP networks can use TDM interconnect circuits to connect to TDM networks. There is therefore no obsolescence in the interconnect link, even if a CP's TDM network is migrated to IP. The availability of media gateways with STM-1 or STM-4 interfaces mean that equipment is available to CPs to interconnect with BT's TDM network.
18. Ofcom's proposal for a regulatory remedy in respect of IP interconnection is unwarranted and involves re-regulating markets that have been unregulated for the best part of a decade. Ofcom is attempting to address a potential problem of TDM interconnects becoming uneconomic without any evidence that it will materialise. Ofcom's intervention may well distort the decision CPs will need to make on when to migrate their TDM voice services onto IP. Any "remedy" should only be imposed after Ofcom has conducted a full investigation of the legal and economic conditions, including the prevailing conditions of competition. BT contends that on the evidence there is no legal or economic basis for the proposed approach set out in this further consultation. BT's obligation to provide TDM interconnect in order to provide access to WCO and WCT services at BT's DLEs is sufficient to address any competition concerns identified within the Narrowband Market Review.

*The proposals are inconsistent with past regulatory decisions and the evidence that the transit and conveyance services are competitive*

19. Ofcom's proposals are in stark contrast to their Fixed Narrowband Services Markets Final Statement of 26 September 2013 and the 2016 Consultation. For instance, at paragraphs 7.10 to 7.12 of the 2013 Final Statement, Ofcom said:

*"In previous reviews, we have identified three markets for transit and conveyance services, corresponding to the provision of ITC/ITT, LTC/LTT and ST.*

...

*In 2005, ... we re-reviewed the ITC/ITT market and found it to be effectively competitive, with all SMP conditions being revoked in accordance with Section 84 of the Act.*

*In 2009 we reviewed the market for LTC/LTT services and found that this market was effectively competitive and removed SMP remedies from LTC/LTT services".*

20. As for single transit (ST) services, Ofcom stated at paragraph 7.1 of the 2013 Final Statement:

*"We have decided that single transit (ST) services should not be subject to ex ante regulation. In particular, we have concluded that ex post competition law will address the competition concerns we have identified in relation to these services, and it is therefore not appropriate to maintain ex ante regulation in relation to these services".*

21. The non-regulation of BT's transit and conveyance services is maintained in the 2016 Consultation which also makes it clear that such services are not subject to fair and reasonable requirements. So, at footnote 477 on page 246, Ofcom says:

*"Conveyance and transit services are unregulated and do not form part of our definition of WCT; as such, we exclude them from consideration of compliance with our F&R guidance".*

22. As for the proper treatment of BT's IPEX, Ofcom says at paragraphs 12.28 to 12.30 of the 2016 Consultation:

*"BT's IPEX provides a number of services including:*

- Transit to numbers on BT's DLEs;*
- Transit between networks; and*
- Termination to numbers hosted on IPEX which cannot be reached via any other POI.*

*Where traffic is routed via IPEX, if the regulated FTR is available at another POI (for example in the first two cases above, where a CP can connect directly to BT's DLEs and/or to other CPs' networks), then the service provided by IPEX constitutes a commercial transit service. ... where traffic must be handed to IPEX because no other POI is available, then the regulated FTR should be charged at the point of handover to IPEX ... . To the extent that additional conveyance is provided (i.e. transit on BT's IPEX), this should be subject to commercial agreement between the hosted CP and BT.*

*We therefore consider that both of the concerns raised by Vodafone are addressed by the current network access condition and therefore we do not propose any changes".*

23. In the 2016 Consultation, Ofcom's regulation of markets which are not considered by the European Commission to be candidates for ex ante regulation was limited to TDM interconnect circuits. At paragraph 17.9 of the 2016 Consultation, Ofcom puts forward the following justification for the

regulation of TDM interconnect circuits:

*“... in the absence of appropriate ex ante regulation of interconnection, BT would be able to exercise the SMP it holds (particularly in relation to WCT, but also in relation to WCO) through the pricing and/or provision of interconnect circuits”.*

24. It is evident that, under the electronic communications regulatory framework, the fundamental regulatory change that Ofcom now envisages, namely the re-regulation of BT's transit and conveyance and the regulation of IP interconnect circuits, must be underpinned by a thorough review of the conditions of competition and must be necessary, proportionate and effective in remedying any perceived competition problem. Indeed, there should be convincing evidence that the competition problem in question is real. A risk that it might materialise is insufficient.

25. Neither IP interconnect circuits, nor transit and conveyance services are identified by the European Commission as markets which should be considered for ex ante regulation. In the 2013 Final Statement, at paragraph 10.10, Ofcom referred to the European Commission's Explanatory Note of 13 November 2007 to justify the regulation of such 'non-identified' markets – in that instance TDM interconnect circuits. In that Note, the Commission said:

*“... in dealing with lack of effective competition arising from a position of SMP in an identified market, it may be necessary to impose several obligations to remedy the competition problem relating to services both inside and outside the market. In principle, an NRA may impose obligations in an area outside but closely related to the relevant market under review, provided such imposition constitutes:*

- the most appropriate, proportionate and efficient means of remedying the lack of effective competition found on the relevant market; and*
- an essential element in support of obligation(s) imposed on the relevant SMP market without which those obligations would be ineffective.”*

26. It is clear, that IP interconnect circuits and transit and conveyance services are not part of either the WCT or WCO market. Consequently, imposing 'fair and reasonable' regulatory obligations in those 'non-identified' markets should meet the above conditions in the Commission's Explanatory Note.

27. It is also apparent from the overall regulatory context, including Articles 5, 8 and 12 of the Access Directive (Directive 2002/19/EC as amended) and the Communications Act 2003, that in the absence of a designation of SMP on a specific market, the imposition of any regulatory obligation relating to IP interconnect circuits and transit and conveyance is subject to strict conditions. Such an obligation would have to be necessary to ensure a competitive market at the retail level. It would also need to be objective, transparent, proportionate and non-discriminatory. The NRA must also take into account the technical and economic viability of using or installing competing facilities. If any one of these conditions is not met then a "Fair and Reasonable" obligation cannot be imposed.

28. In light of this regulatory background, BT suggests that, if TDM interconnect were to be economically unviable, Ofcom would need to examine, amongst other things, whether BT has market power in the

delivery of traffic to the TDM network via IP or if there are viable alternatives available to CPs from the technical and economic perspective. Ofcom's proposals are unsatisfactory as they involve transposing regulation from the TDM world without considering if it is necessary or proportionate. Instead Ofcom proposes a "fair and reasonable" pricing obligation to guard against a perceived risk that BT *might* be able to charge excessively despite the findings in previous market reviews and the proposals in the 2016 Consultation.

29. Ofcom should consider fully the options available for telecoms providers to deliver their traffic to BT's DLEs for termination. For example, CPs may choose to use a third party operator to deliver their traffic to the DLE for termination or may use a media gateway to use a TDM interconnect circuit to deliver IP traffic into BT's TDM network. It is incorrect to assume that TDM interconnection at the DLE requires an operator to maintain its TDM network and that when operators move to an IP network they will necessarily have to migrate to an IP interconnection. It may already be the case that some CPs are leveraging their LLU assets to achieve connectivity to BT's local exchanges.
30. There are a wide range of operators who have already migrated to an IP network and yet have maintained connectivity with BT's local exchanges either directly or through use of BT's IEC or VIC products. This demonstrates that, contrary to Ofcom's assumption, there is no need to maintain a TDM network in order to use TDM interconnect. CPs have been able to agree commercial interconnect arrangements, either direct with BT or via a third party operator, to deliver IP traffic to BT's TDM network. In effect Ofcom's proposals assume the commercial negotiation of interconnect is unable to deliver a satisfactory outcome but there is no evidence in support of that contention.

*Ofcom's Figure 16.2 from the Consultation shows how TDM interconnect to IP networks is possible without the CP having a TDM network<sup>2</sup>*

**Figure 16.2: TDM interconnection between a TDM-based and an IP-based network.**

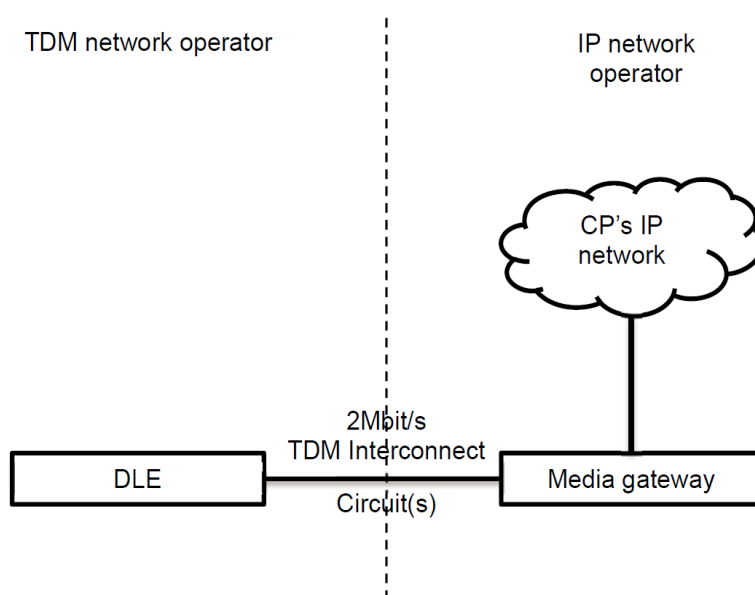

31. Figure 16.2 shows a 2Mbit interconnect circuit between the DLE and the Media Gateway. In fact the

<sup>2</sup> page 304 of Ofcom's December 2016 Narrowband Market Review consultation



interconnect is provided over an STM-1 or STM-4 interface via a point of connection, in the same way as the ISI link is provided, with 2Mbit circuits delivered over this infrastructure.

32. There is no need to maintain any TDM network to interconnect to BT's DLEs as the media gateway has an STM interface to link to the TDM interconnect circuit. In effect the media gateway provides the interworking link between the IP network and the TDM networks.
33. Under Ofcom's proposed SMP conditions in the 2016 Consultation, BT has a requirement to provide Network Access on reasonable request in relation to TDM Interconnect Circuits. BT considers that this requirement is sufficient to ensure the WCO and WCT remedies will be effective.
34. The SMP remedies applying to TDM interconnection circuits are not contingent on whether it remains economic for BT to provide these circuits but remain whilst BT offers WCT and WCO from its TDM DLE switches.
35. As there is no sunset clause on BT's obligation to supply interconnect circuits at the DLE, it is asymmetric to require BT to provide an alternative interconnect arrangement via IP technology simply because CPs have chosen to cease their interconnect circuits.

*BT provides TDM interconnect to a wide range of customers, with nearly all DLEs being connected by more than one operator.*

36. BT provides TDM interconnect circuits to enable access to both WCT and WCO services at BT's local exchanges (DLEs).
37. Customers have a choice of interconnecting directly with BT or using a transit provider. Some operators may find it more economic to interconnect at the Tandem exchanges if traffic volumes are too low to justify interconnection at the DLE.
38. Table 1 below shows the number of DLEs where Operators have TDM interconnect circuits and the total number of Interconnect circuits provided. This data also includes Interconnect Extension Circuits (IECs) and Virtual Interconnect Circuits (VICs) where the handover is typically at a Tandem switch but where traffic is treated as being delivered to the DLE. This allows operators to extend their DLE coverage without needing to build physical infrastructure to the DLEs

**Table 1 Interconnect Circuits to BT DLEs provided to Communications Providers [Confidential]**

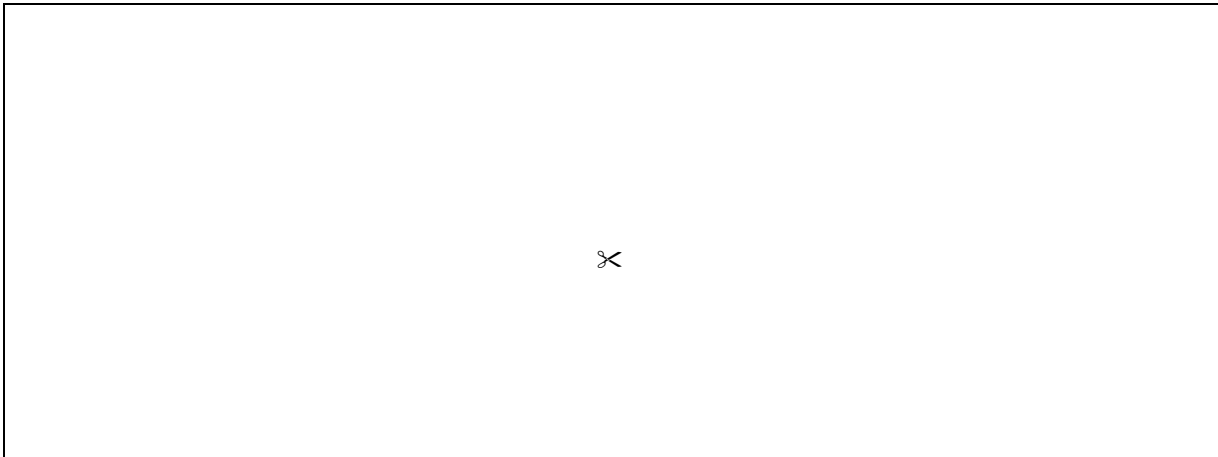

Source: BT, includes ISI, IEC and VIC circuits.

Data extracted in July 2017

39. This data shows that [redacted] have coverage of nearly all the DLEs. In the case of [redacted] this is, in part, due to [redacted]. BT understands that [redacted] has an IP voice network with some legacy TDM switches.- It is possible that media gateways are used to connect TDM interconnect circuits to [redacted] IP network without the need for an intervening TDM switch although BT has no way of knowing what equipment is connected to a TDM interconnect circuit. [redacted].
40. Many CPs do not appear on the list of companies interconnecting at the DLE. This shows that alternative commercial options are being used to access WCT and WCO. Some operators, such as [redacted] use BT's IP Exchange service whilst others will use transit services from other CPs. Sky and Magarathea, who have suggested that BT's IP exchange product should be regulated, [redacted]. These companies have made a commercial choice to use [redacted] and also want BT to be obliged to supply an alternative regulated IP interconnect service. BT considers that this introduces a moral hazard into commercial negotiations if BT is forced to provide a safety net product via a fair and reasonable obligation.
41. Table 1 shows an average of [redacted] 2Mbit interconnect circuits are provided per DLE. This shows TDM traffic carried will support a significant volume of interconnect circuits at each DLE, even as TDM traffic volumes decline. It is worth noting that CPs only need to have one interconnect circuit to deliver TDM traffic to BT (not the 600 or so suggested in the consultation), whilst BT has developed VIC circuits to enable smaller customers to reach DLEs without the need for physical presence at each DLE site.

42. There are a wide range of options available for CPs to interconnect traffic to BT's DLEs. These options include:

- TDM interconnect at DLE (using ISI, IEC, or VIC via Tandem)
- TDM interconnect at Tandem switch (ISI, IEC or CSI)
- TDM interconnect via Third party operator
- IP via Media Gateway to TDM DLE (uses TDM interconnect)
- IP via Media Gateway to TDM Tandem switch (uses TDM interconnect)
- IP via third party operator (uses IP interconnect and a third party conveyance service from the IP network to BT DLEs)
- IP via BT's IP exchange (uses IP interconnect and a BT conveyance service from the IP network to BT's DLEs)

43. This demonstrates the wide range of choice available to CPs. Whilst BT is obliged to provide TDM interconnect at the DLE, there is no reason why other, competitive forms of interconnect via IP should be regulated.

*Ofcom recognises that IP exchange and the conveyance of traffic between IP exchange and the TDM DLE is non-regulated.*

44. Figure 16.3 in the December consultation shows that the use of the IP exchange, the media gateway and conveyance to the DLE is unregulated.

**Figure 16.3: IP interconnection between a TDM-based and an IP-based network.**

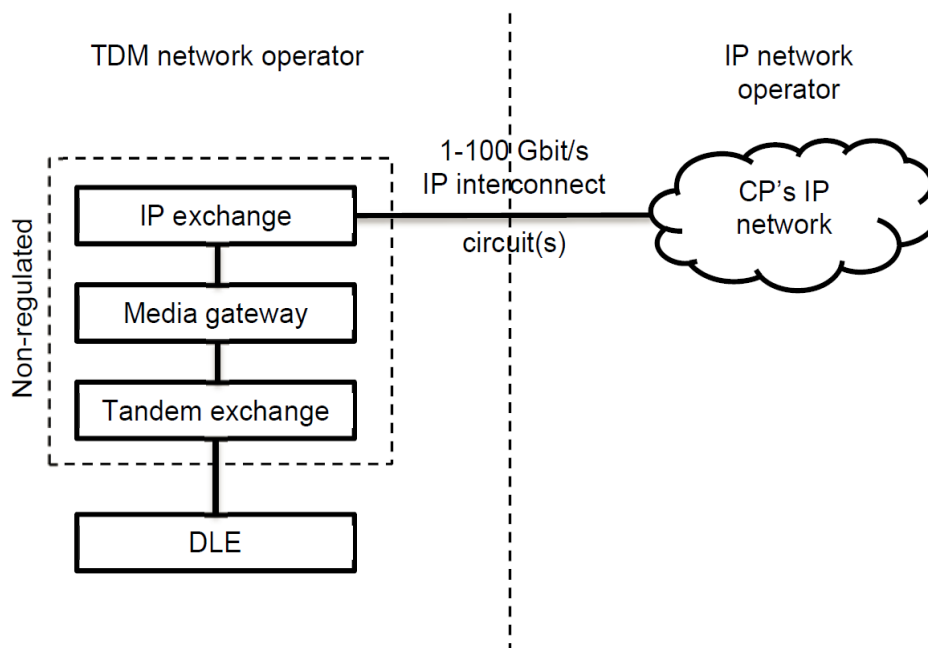

Source: Page 305 of the December Consultation

45. When providing an IP conveyance service from a CP's IP network to BT's DLE, a combination of a number of different elements across competitive markets is being provided.

This includes

- i) An IP Interconnect circuit. (the horizontal line in the diagram.)
- ii) Switching via IP exchange
- iii) Media Gateway providing a conversion from IP to TDM
- iv) Conveyance from the media gateway to the Tandem exchange. This is equivalent to an Inter-Tandem conveyance service
- v) Conveyance over the TDM from the Tandem Exchange to the DLE, being a Local-Tandem conveyance service

46. There is no justification for changing the unregulated status of these components. In terms of alternatives to the IP interconnect circuits, CP's have a number of options. A cable link joining the two networks within the same Telehouse can be bought from a third party, interconnection is possible over the internet, or CPs may elect to self-provide an interconnect link to BT's IP exchange. CPs can negotiate their own commercial arrangements with third party operators to deliver or collect either IP or TDM traffic to BT. Transit services are offered in a competitive market and so are unregulated, with the terms governed by the commercial arrangements agreed between the CPs.

*A number of operators have already migrated to IP or are in the process of migration*

47. A number of significant operators have already migrated their networks to IP (or have moved large parts to IP). Our understanding of the extent of the deployment of IP networks is as follows (Ofcom may wish to confirm this using their formal powers):

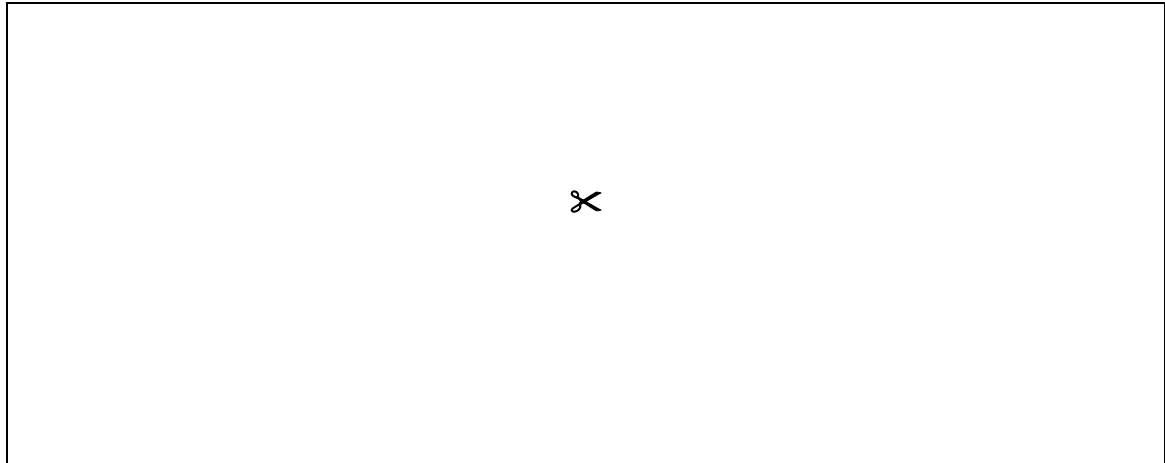

48. These operators have already negotiated commercial terms with BT or other third party operators to deliver IP traffic to BT's TDM network, or have chosen to continue with TDM interconnect using Media Gateways to deliver IP traffic to BT's TDM DLEs. This means the migration from TDM to IP networks does not restrict the options available for delivery of traffic to BT's TDM network, as media gateways allow interworking between IP and TDM networks.
49. The combination of BT's regulated TDM interconnect circuits and commercially negotiated IP interconnection and commercial transit arrangements is an approach which currently operates well. BT sees no reason why Ofcom should extend regulation into an area which is currently subject to commercial negotiation and is competitive.

### *Conclusion*

50. As explained above, Ofcom's proposal for a regulatory remedy in respect of IP interconnection is unwarranted and involves re-regulating markets that have been unregulated for the best part of a decade. Ofcom is attempting to address a potential problem of TDM interconnects becoming uneconomic without any evidence that it will materialise. Ofcom's intervention may well distort the decision CPs will need to make on when to migrate their TDM voice services onto IP. Any "remedy" should only be imposed after Ofcom has conducted a full investigation of the legal and economic conditions in the sector where the remedy is proposed. BT contends that on the evidence there is no legal or economic basis for the proposed approach set out in this further consultation. BT's obligation to provide TDM interconnect in order to provide access to WCO and WCT services at BT's DLEs is sufficient to address any competition concerns identified within the Narrowband Market Review.